

CINCON ELECTRONICS

33-700 WATTS BRICK DC-DC CONVERTER CATALOG 2019

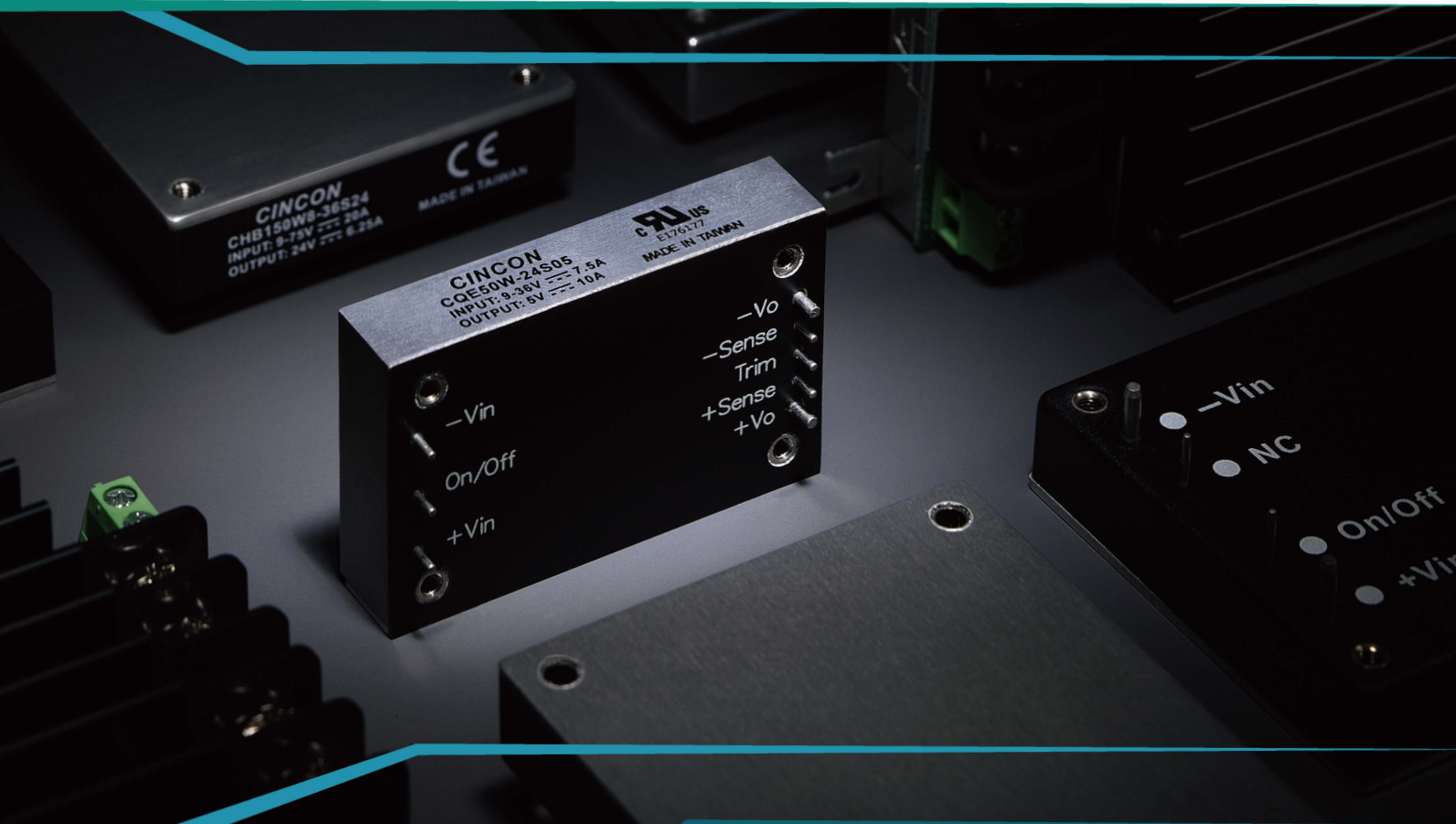

CONTENTS

QUICK SELECTION	2	CHB150W	150W	46	NEW	CHB300W-110SXX-CMFC(D) 300W	92			
		CHB150-110S	150W	48	NEW	CHB300-300SXX CMFC(D)	300W 94			
CQE50W	50W	4	CHB150W8	150W	50	NEW	CHB600W-110SXX CMFD	600W 96		
NEW	CQB50W12	30-50W	6	NEW	CHB150W10	150W	52	FM FILTER MODULE	10-20A 98	
	CQE60W-110S	60W	8	NRND	CHB200	200W	54	NEW	FM30	30A 100
	CQB75W	75W	10		CHB200W	200W	56	NEW	FM10D200P	10A 102
NEW	CQB75W8	75W	12	NEW	CHB200W-110	200W	58		HEATSINK	104
	CQB100W	100W	14	NEW	CHB200W10	200W	60		SIPSMT05-05	5A 106
	CQB100-110S	100W	16		CHB300W	300W	62		SIPSMT05-12	5A 108
NEW	CQB100W-110S	100W	18		CHB300W-110S	300W	64		SIPSMT10-05	10A 110
	CQB150W	150W	20		CHB300-300S	300W	66		SIPSMT10-12	10A 112
	CQB150W-110S	150W	22		CHB350	350W	68		SIPSMT10W-12	10A 114
	CQB150-300S	150W	24	NRND	CFB200	200W	70		SIPSMT15-05	15A 116
	CHB50	50W	26		CFB400W	400W	72		SIPSMT16-12	16A 118
	CHB50W	50W	28		CFB600	600-700W	74		SIPSMT16W-12	16A 120
	CHB75	75W	30	NEW	CFB600W-110S	600W	76		SIP20W-12	20A 122
	CHB75W	75W	32		CFB600-300S	600W	78			
	CHB75-Dual	75W	34	NEW	CFB750-300S	750W	80		Resquest for Quote 50W	124
	CHB100	100W	36		CQB CHASSIS MOUNT&DIN-RAIL	33-100W	82			
	CHB100-110S	100W	38	NEW	CQB50W12-72S CMFC(D)	30-50W	84			
	CHB100W	100W	40	NEW	CQB150-300SXX-CMFC(D)	150W	86			
	CHE100W	100W	42	NEW	CQB150W-110SXX-CMFC(D)	150W	88			
	CHB150	150W	44		CHB CHASSIS MOUNT&DIN-RAIL	33-100W	90			

QUICK SELECTION

Input Voltage Range	Package	Output Voltage (V) and Max Power (W)									I/O Isolation	Series	Page
		3.3V	5V	12V	15V	24V	28V	32V	36V	48V			
12 V (9 – 18 V)	Half Brick	33W	50W	50W	50W	50W					1500VDC	CHB50	26
	Half Brick	49.5W	75W	75W	75W	75W					1500VDC	CHB75	30
24 V %28 V (18 – 36 V)	Half Brick	33W	50W	50W	50W	50W					1500VDC	CHB50	26
	Half Brick	49.5W	75W	75W	75W	75W					1500VDC	CHB75	30
	Half Brick	66W	100W	100W	100W	100W					1500VDC	CHB100	36
	Half Brick	165W	200W	200W		200W				200W	1500VDC	CHB200	54
	Half Brick	231W	350W	350W		350W	350W			350W	1500VDC	CHB350	68
	Full Brick			600W		600W	600W	600W		600W	1500VDC	CFB600	74
12, 24 & 28 V (9 – 36 V)	Quarter Brick	33W	50W	50W	50W	50W				50W	1500VDC	CQE50W	4
	Quarter Brick	39.6W	60W	75W	75W	75W					1500VDC	CQB75W	10
	Quarter Brick	99W	100W	100W	100W	100W					1500VDC	CQB100W	14
	Quarter Brick		150W	150W		150W	150W			150W	1500VDC	CQB150W	20
	Half Brick	33W	50W	50W	50W	50W	50W			50W	1500VDC	CHB50W	28
	Half Brick	49.5W	75W	75W	75W	75W	75W			75W	1500VDC	CHB75W	32
	Half Brick	66W	100W	100W	100W	100W	100W			100W	1500VDC	CHB100W	40
	Half Brick	82.5W	100W	100W	100W	100W				100W	1500VDC	CHE100W	42
	Half Brick	99W	150W	150W	150W	150W	150W			150W	1500VDC	CHB150W	44
	Half Brick		300W	300W	300W	300W	300W			300W	1500VDC	CHB300W	62
Half Brick		400W	400W		400W	400W			400W	1500VDC	CFB400W	72	
12, 24 & 28 V (10 – 36 V)	Half Brick	165W	200W	200W	200W	200W				200W	1500VDC	CHB200W	56
48 V (36 – 75 V)	Half Brick	33W	50W	50W	50W	50W					1500VDC	CHB50	26
	Half Brick	49.5W	75W	75W	75W	75W					1500VDC	CHB75	30
	Half Brick	66W	100W	100W	100W	100W					1500VDC	CHB100	36
	Half Brick	99W	150W	150W	150W	150W					1500VDC	CHB150	44
	Half Brick	165W	200W	200W		200W				200W	1500VDC	CHB200	54
	Half Brick	231W	350W	350W		350W	350W				1500VDC	CHB350	68
	Full Brick			600W		600W	700W	600W		600W	1500VDC	CFB600	74

Modified Product Support

Recognizing the requirements for matching standard products to unique applications, Cincon is dedicated to provide support for customers requiring additional features or modification to catalog products.

Input Voltage Range	Package	Output Voltage (V) and Max Power (W)									I/O Isolation	Series	Page
		3.3V	5V	12V	15V	24V	28V	32V	36V	48V			
24, 28 & 48 V (18 – 75 V)	Quarter Brick	33W	50W	50W	50W	50W				50W	1500VDC	CQE50W	4
	Quarter Brick	39.6W	60W	75W	75W	75W					1500VDC	CQB75W	10
	Quarter Brick	99W	100W	100W	100W	100W					1500VDC	CQB100W	12
	Quarter Brick		150W	150W		150W	150W			150W	2250VDC	CQB150W	20
	Half Brick	33W	50W	50W	50W	50W	50W			50W	1500VDC	CHB50W	28
	Half Brick	49.5W	75W	75W	75W	75W	75W			75W	1500VDC	CHB75W	32
	Half Brick	66W	100W	100W	100W	100W	100W			100W	1500VDC	CHB100W	40
	Half Brick	82.5W	100W	100W	100W	100W				100W	1500VDC	CHE100W	42
	Half Brick	99W	150W	150W	150W	150W	150W			150W	1500VDC	CHB150W	44
	Half Brick	165W	200W	200W	200W	200W				200W	1500VDC	CHB200W	56
	Half Brick		300W	300W		300W	300W			300W	1500VDC	CHB300W	62
Full Brick		400W	400W		400W	400W			400W	1500VDC	CFB400W	72	
12, 24, 28, 36 & 48 V (9 to 75 V)	Quarter Brick			75W	75W	75W	75W			75W	3000VAC	CQB75W8-36	12
	Half Brick			150W	150W	150W	150W			150W	1500VDC	CHB150W8	50
72, 96 & 110 V (43 – 160 V)	Quarter Brick		60W	60W	60W	60W	60W			60W	3000VDC	CQB60W-110S	8
	Quarter Brick		100W	100W		100W	100W			100W	3000VDC	CQB100W-110S	18
	Quarter Brick	99W	150W	150W		150W	150W			150W	3000VDC	CQB150W-110S	22
	Half Brick		200W	200W		200W	200W			200W	3000VDC	CHB200W-110S	58
	Half Bricks	198W	300W	300W		300W	300W			300W	3000VDC	CHB300W-110S	64
	Full Brick			600W		600W	600W			600W	2250VDC	CFB600W-110S	76
24, 28, 36, 48, 72, 96 & 110 V (14-160V)	Quarter Brick		30W	50W		50W				50W	3000VDC	CQB50W12	6
24, 28, 36, 48, 72, 96 & 110 V (14.5-140V)	Half Brick		150W	150W	150W	150W				150W	3000VAC	CHB150W10	52
	Half Brick		200W	200W	200W	200W				200W	3000VAC	CHB200W10	60
110 V (66 – 160 V)	Quarter Brick	82.5W	100W	100W		100W					2250VDC	CQB100-110S	16
	Half Brick			100W	100W	100W				100W	3000VAC	CHB100-110S	38
	Half Brick		150W	150W		150W					2250VDC	CHB150-110S	48
300 V (180 – 425 V)	Quarter Brick		150W	150W	150W	150W	150W			150W	3000VAC	CQB150-300S	24
	Half Brick		300W	300W		300W	300W			300W	3000VAC	CHB300-300S	66
	Full Brick			600W		600W	600W				3000VAC	CFB600-300S	78
	Full Brick			750W	750W	750W	750W		750W	750W	3000VAC	CFB750-300S	80

CQE50W SERIES

50 WATT, 4:1 INPUT RANGE

Features

- ◆ 50W Isolated Output
- ◆ No Tantalum Capacitor Inside
- ◆ Quarter-Brick Size, Six-Sided Shield Metal Case
- ◆ High Efficiency up to 92%
- ◆ 300KHz Switching Frequency
- ◆ 4 : 1 Input Range
- ◆ Regulated Outputs
- ◆ Continuous Short Circuit Protection
- ◆ Full Load Operation up to 80°C with Heat-Sink M-C421 Natural Convention
- ◆ Over Temperature/Voltage/Current Protection
- ◆ Safety Meets UL60950-1, EN60950-1, and IEC60950-1



Mechanical Dimensions

II Dimensions in Inches (mm)
 Tolerance Inches: X.XX±0.02, X.XXX±0.010
 Millimeters: X.X±0.5, X.XX±0.25

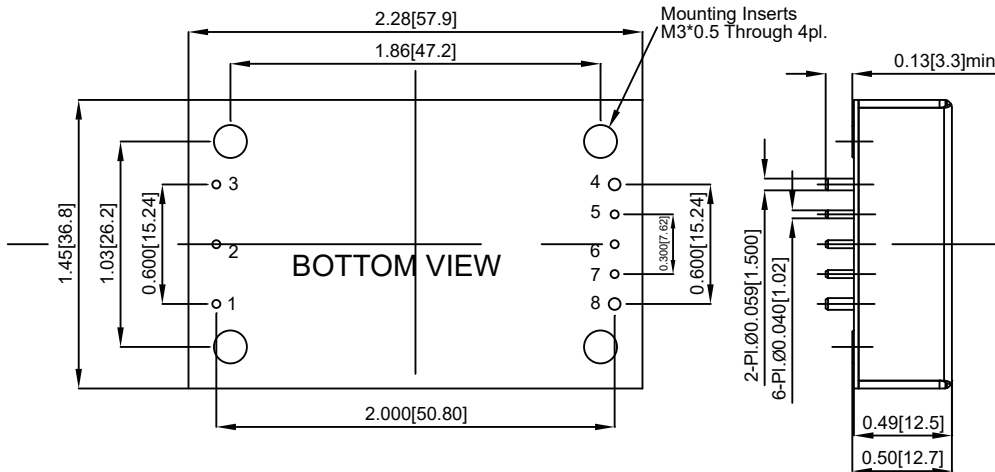

PIN CONNECTION	
PIN	Single Output
1	+V Input
2	On/Off
3	-V Input
4	-V Output
5	-Sense
6	Trim
7	+Sense
8	+V Output

MODEL NUMBER	INPUT VOLTAGE	OUTPUT VOLTAGE	OUTPUT CURRENT		INPUT CURRENT		% EFF.		CAPACITOR LOAD MAX.
			MIN.	MAX.	NO LOAD	FULL LOAD	(2)	(3)	
CQE50W-24S3V3	9-36 VDC	3.3 VDC	0 mA	10 A	100 mA	1528 mA	90	90.5	10000µF
CQE50W-24S05	9-36 VDC	5 VDC	0 mA	10 A	100 mA	2277 mA	91	91.5	10000µF
CQE50W-24S12	9-36 VDC	12 VDC	0 mA	4.16 A	100 mA	2261 mA	91	91.5	4160µF
CQE50W-24S15	9-36 VDC	15 VDC	0 mA	3.33 A	100 mA	2287 mA	91.5	91.5	3330µF
CQE50W-24S24	9-36 VDC	24 VDC	0 mA	2.08 A	60 mA	2311 mA	90	90	2080µF
CQE50W-24S48	9-36 VDC	48 VDC	0 mA	1.04 A	60 mA	2311 mA	88.5	88.5	1040µF ⁽⁴⁾
CQE50W-48S3V3	18-75 VDC	3.3 VDC	0 mA	10 A	60 mA	764 mA	90	90	10000µF
CQE50W-48S05	18-75 VDC	5 VDC	0 mA	10 A	60 mA	1132 mA	91.5	92	10000µF
CQE50W-48S12	18-75 VDC	12 VDC	0 mA	4.16 A	60 mA	1130 mA	92	92	4160µF
CQE50W-48S15	18-75 VDC	15 VDC	0 mA	3.33 A	60 mA	1144 mA	91	91	3330µF
CQE50W-48S24	18-75 VDC	24 VDC	0 mA	2.08 A	60 mA	1156 mA	91	90.5	2080µF
CQE50W-48S48	18-75 VDC	48 VDC	0 mA	1.04 A	60 mA	1156 mA	89	89	1040µF ⁽⁴⁾

NOTE:

1. Nominal Input Voltage 24, 48VDC
2. Measured at 12VDC for 24SXX, 24VDC for 48SXX
3. Measured at Nominal Input Voltage
4. Require a 10uF Aluminum Capacitor Connected Between +Vout and -Vout for 48Vout Models

Remote On/Off Control

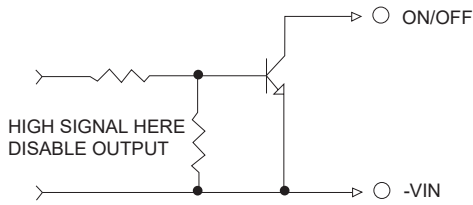

External Output Trim

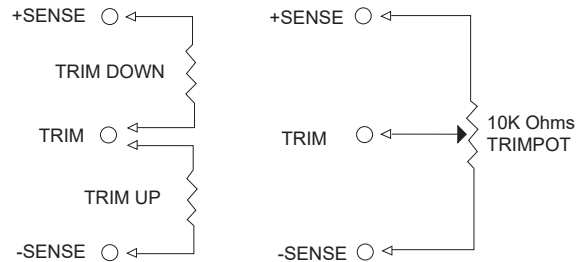

Derating Curve

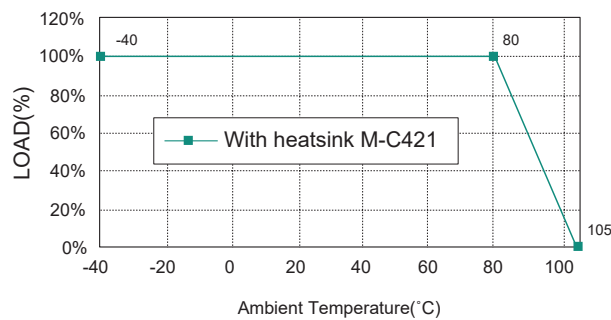

Specifications

All Specifications Typical At Nominal Line, Full Load, and 25°C Unless Otherwise Noted

INPUT SPECIFICATIONS

Input Voltage Range	24V 9-36V	48V..... 18-75V
Input Surge Voltage (100ms max.)	24V 50Vdc max.	48V 100Vdc max.
Under voltage lockout	24Vin	power up 8.8V power down 8.0V
	48Vin	power up 17V power down 16V
Positive Logic Remote On/Off	See note 4 & 5	
Input Filter	PI Type	

OUTPUT SPECIFICATIONS

Voltage Accuracy:	±1.5% max.
Transient Response: 75% to 100% Step Load Change	
Error Band	±5% Vout
Recover Time	< 500µs
External Trim Adj. Range	±10%
Ripple & Noise, 20MHz BW (see note 3)	
3.3V & 5V	40mV RMS, 100mV pk-pk max.
12V & 15V	60mV RMS, 150mV pk-pk max.
24V	100mV RMS, 240mV pk-pk max.
48V	200mV RMS, 480mV pk-pk max.
Temperature Coefficient	±0.03%/°C
Short Circuit Protection	Continuous
Line Regulation (note 1)	±0.2% max.
Load Regulation (note 2)	±0.2% max.
Over Voltage Protection trip Range, % Vo nom.	115-140%
Current Limit	110%-165% Nominal Output
Start up time	20ms typ.

GENERAL SPECIFICATIONS

Efficiency	See Table
Isolation Voltage	Input/Output 1500VDC min. Input/Case 1500VDC min. Output/Case 1500VDC min. 10 ⁷ ohm min.
Isolation Resistance	1000pF typ
Isolation Capacitance	300KHz typ.
Switching Frequency	-40°C to 105°C
Operating Case Temperature	-55°C to +125°C
Storage Temperature	110°C typ.
Thermal Shutdown, Case Temp.	95% RH max. Non condensing
Humidity	XXS24, XXS48 800Khrs typ. Others 600Khrs typ.
MTBF ... MIL-HDBK-217F, GB, 25°C, Full Load	1.45 x 2.28 x 0.50 inches (36.8 x 57.9 x 12.7 mm)
Dimensions	Aluminum with Non-Conducted Base
Case Material	63 g
Weight	

NOTE

- Measured from high line to low line.
- Measured from full load to zero load.
- Output ripple and noise measured with 10µF aluminum and 1µF ceramic capacitor across output for 48Vout and with 10µF tantalum and 1µF ceramic capacitor for others.
- Logic compatibility open collector ref to -Input
Module On >3.5VDC to 75VDC or open circuit
Module Off < 1.2VDC
- Suffix "N" to the model number with negative logic remote On/Off
Module On < 1.2VDC
Module Off >3.5VDC to 75VDC or open circuit

CQB50W12 SERIES

30-50 WATT 12:1 INPUT DC-DC CONVERTERS

Features

- ◆ 30-50W Isolated Output
- ◆ Efficiency to 89%
- ◆ Fixed Switching Frequency
- ◆ 12:1 Input Range
- ◆ Regulated Outputs
- ◆ Remote On/Off
- ◆ Low No Load Power Consumption
- ◆ Over Temperature Protection
- ◆ Over Voltage/Current Protection
- ◆ Continuous Short Circuit Protection
- ◆ Quarter Brick Size Meet Industrial Standard
- ◆ UL60950-1 2nd(Basic Insulation) Approval
- ◆ CB Test Certificate IEC60950-1
- ◆ Meet EN50155 with External Circuits
- ◆ Shock & Vibration Meets EN50155 (EN61373)
- ◆ Fire & Smoke Meet EN45545-2
- ◆ 5000m Operating Altitude



Mechanical Dimensions

All Dimensions In Inches(mm)
 Tolerances Inches: X.XX= ±0.02, X.XXX= ±0.010
 Millimeters: X.X= ±0.5, X.XX=±0.25

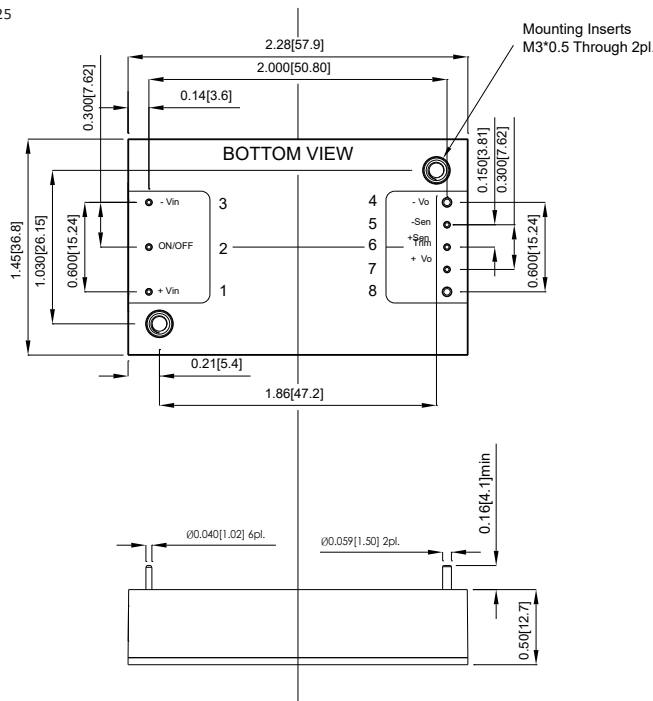

PIN CONNECTION	
PIN	Function
1	+V Input
2	On/Off
3	-V Input
4	-V Output
5	-Sense
6	Trim
7	+Sense
8	+V Output

MODEL NUMBER	INPUT VOLTAGE	OUTPUT VOLTAGE	OUTPUT CURRENT		INPUT CURRENT		% EFF.		CAPACITOR LOAD MAX.
			MIN.	MAX.	NO LOAD	FULL LOAD	(1)	(2)	
CQB50W12-72S05	14-160 VDC	5 VDC	0 mA	6.0 A	5 mA	530 mA	83	81	10000µF
CQB50W12-72S12	14-160 VDC	12 VDC	0 mA	4.2 A	5 mA	810 mA	87	86	6800µF
CQB50W12-72S24	14-160 VDC	24 VDC	0 mA	2.1 A	5 mA	810 mA	89	87	3300µF
CQB50W12-72S48	14-160 VDC	48 VDC	0 mA	1.05 A	8 mA	810 mA	88	85	680µF

NOTE:
 1. Nominal Input Voltage 72 VDC
 2. Measured at 110Vin

Remote On/Off Control

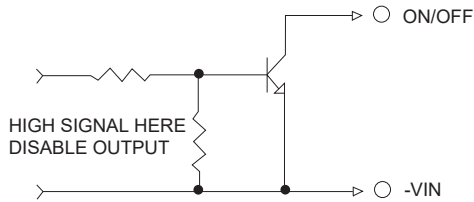

External Output Trim

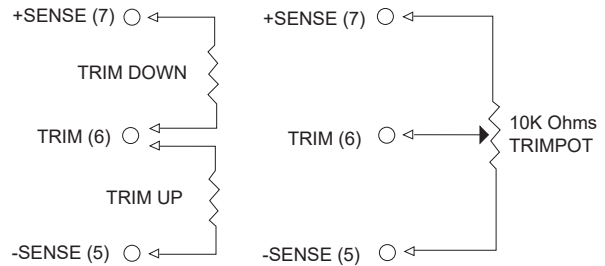

Specifications

All Specifications Typical At Nominal Line, Full Load, and 25°C Unless Otherwise Noted

INPUT SPECIFICATIONS

Input Voltage Range	72V 14-160V
Input Surge Voltage (100ms max.)	200Vdc max.
Under voltage lockout	power up 14.6V power down 12.0V
Positive Logic Remote On/Off	See note 4 & 5
Input Filter	PI Type

OUTPUT SPECIFICATIONS

Voltage Accuracy:	±1.0% max.
Transient Response: 25% Step Load Change	<250µs
External Trim Adj. Range	-20%, +10%
Ripple & Noise, 20MHz BW (see note 3)	40mV RMS, 100mV pk-pk max.
Temperature Coefficient	±0.02%/°C
Short Circuit Protection	Continuous
Line Regulation (note 1)	±0.2% max.
Load Regulation (note 2)	±0.2% max.
Over Voltage Protection trip Range, % Vo nom.	115-140%
Current Limit	110%-220% Nominal
Start up time	Output 30ms typ.

GENERAL SPECIFICATIONS

Efficiency	See Table
Isolation Voltage	Input/Output 3000VDC min. Input/Case 2500VDC min. Output/Case 500VAC min.
Isolation Resistance	2x10 ⁸ ohm min.
Isolation Capacitance	1000pF typ
Switching Frequency	240KHz typ.
Operating Case Temperature	-40°C to 100°C
Storage Temperature	-55°C to +125°C
Thermal Shutdown, Case Temp.	110°C typ.
Humidity	95% RH max. Non condensing
Operating Altitude	5000m
MTBF ... MIL-HDBK-217F, GB, 25°C, Full Load	780Khrs typ.
Safety	UL60950-1 2 nd (Basic insulation)
EMC (note 8)	EN50155 (EN50121-3-2) with External Filter
Shock/Vibration	EN50155 (EN61373)
Environmental	EN50155 (EN60068-2-1)
Fire & Smoke	EN45545-2
Dimensions	2.28 x 1.45 x 0.50 inches (57.9 x 36.8 x 12.7 mm)
Case Material	Aluminum Baseplate with Plastic Case
Weight	61.5 g

NOTE

1. Measured from high line to low line.
2. Measured from full load to zero load.
3. Output ripple and noise measured with 22µF aluminum solid capacitor and 1µF ceramic capacitor across output.
4. Logic compatibility open collector ref to -Input
Module on > 3.5VDC to 160VDC or open circuit
Module off 0 to <1.2 VDC
5. Suffix "N" to the model number with negative logic remote on/off
Module on 0 to <1.2 VDC
Module off >4.0VDC to 160VDC or open circuit
6. Suffix "-C" to the model number with clear mounting insert (3.2mm DIA.)
7. An external input capacitor 68µF for all models are recommended to reduce input ripple voltage
8. For information about EN50155 and RIA12, refer to application note.

CQB60W-110S SERIES

60 WATT, INPUT RANGE 43-160 VDC

Features

- ◆ 60W Isolated Output
- ◆ Efficiency to 92%
- ◆ Low No Load Power Consumption
- ◆ 4 : 1 Input Range
- ◆ Regulated Outputs
- ◆ Remote On/Off
- ◆ Over Temperature/Voltage/Current Protection
- ◆ Continuous Short Circuit Protection
- ◆ Quarter Brick Size Meets Industrial Standard
- ◆ UL60950-1 (Basic Insulation) Approval
- ◆ Meets EN50155 with External Circuits
- ◆ Shock & Vibration: EN 50155 (EN 61373)
- ◆ Fire & Smoke Meets EN45545-2
- ◆ 4000m Operating Altitude



Mechanical Dimensions

All Dimensions in Inches (mm)
 Tolerance Inches: X.XX=±0.02, X.XXX=±0.010
 Millimeters: X.X=±0.5, X.XX=±0.25

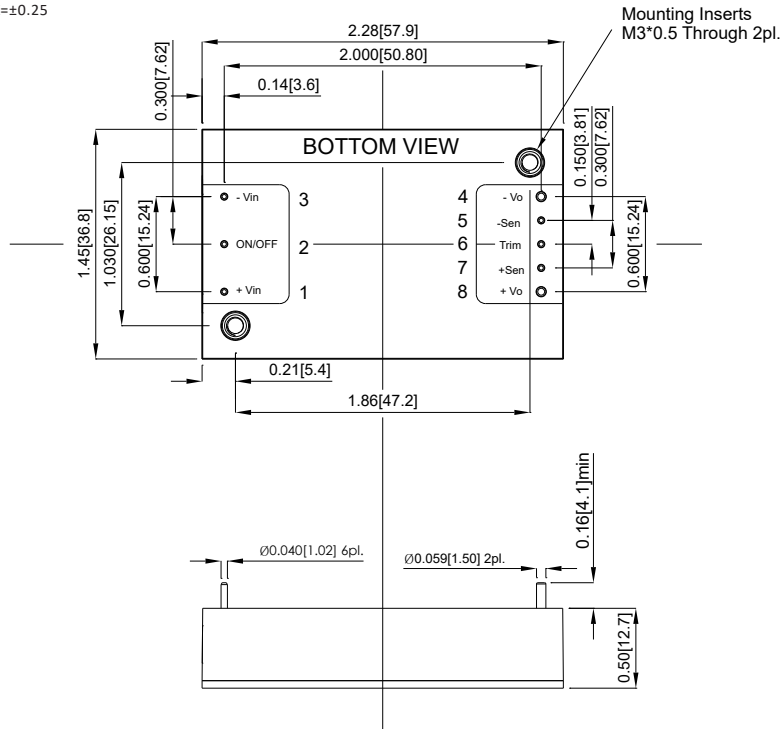

PIN CONNECTION	
PIN	Single Output
1	+V Input
2	On/Off
3	-V Input
4	-V Output
5	-Sense
6	Trim
7	+Sense
8	+V Output

MODEL NUMBER	INPUT VOLTAGE	OUTPUT VOLTAGE	OUTPUT CURRENT		INPUT CURRENT		% EFF.	CAPACITOR LOAD MAX.
			MIN.	MAX.	NO LOAD	FULL LOAD		
CQB60W-110S05	43-160 VDC	5 VDC	0 mA	12 A	5 mA	600 mA	91	6800µF
CQB60W-110S12	43-160 VDC	12 VDC	0 mA	5 A	5 mA	593 mA	92	3300µF
CQB60W-110S15	43-160 VDC	15 VDC	0 mA	4 A	5 mA	606 mA	90	3300µF
CQB60W-110S24	43-160 VDC	24 VDC	0 mA	2.5 A	5 mA	606 mA	90	1200µF
CQB60W-110S28	43-160 VDC	28 VDC	0 mA	2.14 A	5 mA	606 mA	90	1200µF
CQB60W-110S48	43-160 VDC	48 VDC	0 mA	1.25 A	5 mA	613 mA	89	470µF

Remote On/Off Control

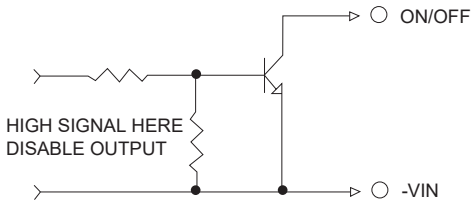

External Output Trim

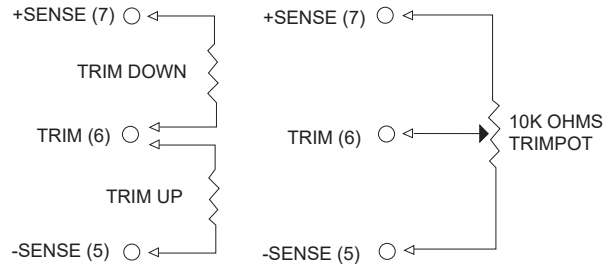

Specifications

All Specifications Typical At Nominal Line, Full Load, and 25°C Unless Otherwise Noted

INPUT SPECIFICATIONS

Input Voltage Range	110V, 43-160V
Input Surge Voltage (100ms max.)	180Vdc max.
Under Voltage Lockout	Power up..... 42V Power down... 38V
Positive Logic Remote On/Off	See note 4 & 5
Input Filter	PI Type

OUTPUT SPECIFICATIONS

Voltage Accuracy	±1.0% max.
Transient Response:	
25% Step Load Change	< 250µs
External Trim Adj. Range	±10%
Ripple & Noise, 20MHz BW (note 3)	
5V	40mV RMS, 100mV pk-pk max.
12V/15V	60mV RMS, 150mV pk-pk max.
24V/28V	100mV RMS, 240mV pk-pk max.
48V	200mV RMS, 480mV pk-pk max.
Temperature Coefficient	±0.03%/°C
Short Circuit Protection	Continuous
Line Regulation (note 1)	±0.2% max.
Load Regulation (note 2)	±0.2% max.
Over Voltage Protection trip Range, % Vo nom	115-140%
Current Limit	110%-165% Nominal Output
Start up time	15ms typ.

GENERAL SPECIFICATIONS

Efficiency	See Table
Isolation Voltage	Input/Output3000VDC min. Input/Case3000VDC min. Output/Case1500VDC min. 10 ⁷ ohm min.
Isolation Resistance	1000pF typ.
Isolation Capacitance	200KHz typ.
Switching Frequency	-40°C to +100°C
Operating Case Temperature	-55°C to +105°C
Storage Temperature	110°C typ.
Thermal Shutdown, Case Temp	95% RH max. Non condensing
Humidity	4000m
Operating Altitude	MIL-HDBK-217F, GB, 25°C, Full Load 650Khrs typ
MTBF	UL60950-1 2 nd (Basic insulation) EN50155 (EN50121-3-2) with external filter EN50155 (EN61373)
Safety	2.28 × 1.45 × 0.50 inches (57.9 × 36.8 × 12.7 mm)
EMI	Aluminum Baseplate with Plastic Case
Shock/Vibration	61.5 g
Dimensions	
Case Material	
Weight	

NOTE

1. Measured from high line to low line.
2. Measured from full load to zero load.
3. Output ripple and noise measured with 10µF tantalum and 1µF ceramic capacitor across output.
4. Logic compatibility open collector ref to -Input
Module On > 3.5VDC to 75VDC or open circuit
Module Off < 1.2VDC
5. Suffix "N" to the model number with negative logic remote On/Off
Module On < 1.2VDC
Module Off >3.5VDC to 75VDC or open circuit
6. Suffix "-C" to the model number with clear mounting Insert (3.2mm DIA.)
7. An external input capacitor 68µF for all models are recommended to reduce input ripple voltage.
8. Design to meet EN50155 and RIA12 refer to application note.

CQB75W SERIES

75 WATT, 4:1 INPUT RANGE

Features

- ◆ 75W Isolated Output
- ◆ Efficiency up to 87%
- ◆ Fixed Switching Frequency
- ◆ 4 : 1 Input Range
- ◆ Regulated Outputs
- ◆ Continuous Short Circuit Protection
- ◆ Industry Standard Quarter-Brick Package
- ◆ UL60950-1 2nd Approval



Mechanical Dimensions

All Dimensions in Inches (mm)
 Tolerance Inches: X.XX=±0.02, X.XXX=±0.010
 Millimeters: X.X=±0.5, X.XX=±0.25

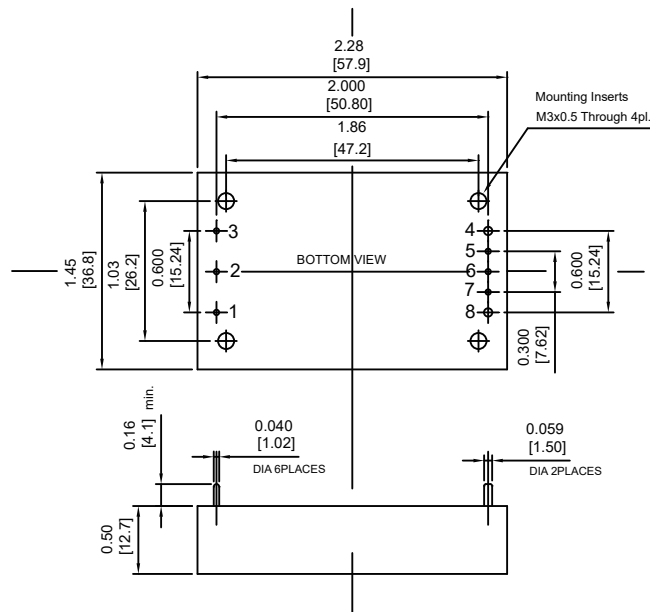

PIN CONNECTION	
PIN	Single Output
1	+V Input
2	On/Off
3	-V Input
4	-V Output
5	-Sense
6	Trim
7	+Sense
8	+V Output

MODEL NUMBER	INPUT VOLTAGE	OUTPUT VOLTAGE	OUTPUT CURRENT		INPUT CURRENT		% EFF.	CAPACITOR LOAD MAX.
			MIN.	MAX.	NO LOAD	FULL LOAD		
CQB75W-24S3V3	9-36 VDC	3.3 VDC	0 mA	12 A	50 mA	2037 mA	81	12000µF
CQB75W-24S05	9-36 VDC	5 VDC	0 mA	12 A	50 mA	2976 mA	84	12000µF
CQB75W-24S12	9-36 VDC	12 VDC	0 mA	6.25 A	50 mA	3634 mA	86	6250µF
CQB75W-24S15	9-36 VDC	15 VDC	0 mA	5 A	50 mA	3634 mA	86	4400µF
CQB75W-24S24	9-36 VDC	24 VDC	0 mA	3.12 A	50 mA	3628 mA	86	1500µF
CQB75W-48S3V3	18-75 VDC	3.3 VDC	0 mA	12 A	30 mA	1006 mA	82	12000µF
CQB75W-48S05	18-75 VDC	5 VDC	0 mA	12 A	30 mA	1471 mA	85	12000µF
CQB75W-48S12	18-75 VDC	12 VDC	0 mA	6.25 A	30 mA	1817 mA	86	6250µF
CQB75W-48S15	18-75 VDC	15 VDC	0 mA	5 A	30 mA	1796 mA	87	4400µF
CQB75W-48S24	18-75 VDC	24 VDC	0 mA	3.12 A	30 mA	1796 mA	87	1500µF

External Output Trim

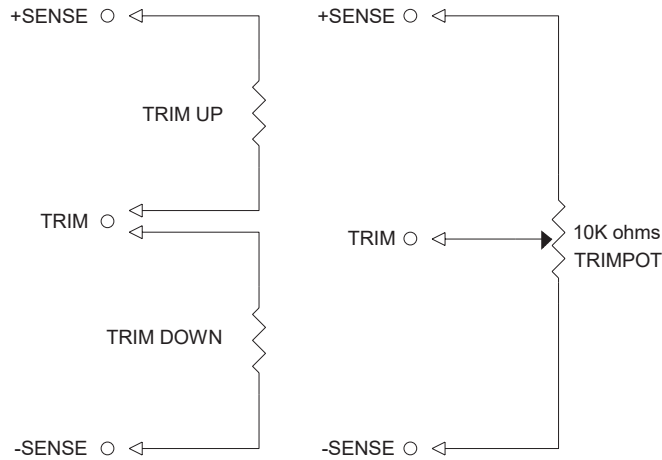

Specifications

All Specifications Typical At Nominal Line, Full Load, and 25°C Unless Otherwise Noted

INPUT SPECIFICATIONS

Input Voltage Range	24V..... 9-36V
	48V..... 18-75V
Input Surge Voltage (100ms max.)	24V 50Vdc max.
	48V 100Vdc max.
Under voltage lockout	24Vin
	power up 8.8V
	power down 8.0V
	48Vin
	power up 17V
	power down 16V
Positive Logic Remote On/Off	See note 4 & 5
Input Filter	PI Type

OUTPUT SPECIFICATIONS

Voltage Accuracy:	±1.0%max.
	24(48)S33:±1.5% max.
Transient Response : 75% to 100% Step Load Change	
Error Band	±5% Vout
Recover Time	< 500µs
External Trim Adj. Range	±10%°C
Ripple & Noise, 20MHz BW (note 3)	
3.3V & 5V	40mV RMS, max.
	100mV pk-pk, max.
12V & 15V	60mV RMS, max.
	150mV pk-pk, max.
24V	100mV RMS, max.
	240mV pk-pk, max.
Temperature Coefficient	±0.03%/°C
Short Circuit Protection	Continuous
Line Regulation (note 1)	±0.2% max.
Load Regulation (note 2)	±0.2% max.
Over Voltage Protection trip Range, % Vo nom.	115-140%
Current Limit	110%-140% Nominal Output
Start up time	20ms typ.

GENERAL SPECIFICATIONS

Efficiency	See Table
Isolation Voltage	Input/Output 1500VDC min.
	Input/Case1500VDC min.
	Output/Case 1500VDC min.
	10 ⁷ ohm min.
Isolation Resistance	
Isolation Capacitance	1000pF Typ.
Switching Frequency	300KHz, Typ.
Operating Case Temperature Storage	-40°C to 100°C
Temperature	-55°C to +105°C
Humidity	95% RH max. Non condensing
MTBF	MIL-HDBK-217F, GB, 25°C, Full Load
	850Khrs typ.
Thermal Shutdown, Case Temp.	- 105°C Typ.
Dimensions	1.45 x 2.28 x 0.50 inches
	(36.8 x 57.9 x 12.7 mm)
Case Material	Aluminum Base-plate with Plastic
	Case
Weight	63 g

NOTE

1. Measured from high line to low line.
2. Measured from full load to zero load.
3. Output ripple and noise measured with 10µF tantalum and 1µF ceramic capacitor across output.
4. Logic compatibility open collector ref to -Input
| Module On >3.5VDC to 75VDC or open circuit |
| Module Off 0 to < 1.8Vdc |
5. Suffix "N" to the model number with negative logic remote On/Off
| Module On 0 to < 1.8Vdc |
| Module Off >3.5VDC to 75Vdc or open circuit |
6. Suffix "-C" to the model number with clear mounting Insert (3.1mm DIA.)

CQB75W8 SERIES

75 WATT 8:1 INPUT DC-DC CONVERTERS

Features

- ◆ 75W Isolated Output
- ◆ Efficiency to 90%
- ◆ Fixed Switching Frequency
- ◆ 8:1 Input Range
- ◆ Regulated Outputs
- ◆ Remote On/Off
- ◆ Low No Load Power Consumption
- ◆ Over Temperature Protection
- ◆ Over Voltage/Current Protection
- ◆ Continuous Short Circuit Protection
- ◆ Quarter Brick Size Meet Industrial Standard
- ◆ Safety Meet UL62368 (Reinforced Insulation)
- ◆ Meet EN50155 with External Circuits
- ◆ Shock & Vibration Meet EN50155 (EN61373)
- ◆ Fire & Smoke Meet EN45545-2
- ◆ 3000m Operating Altitude

PRELIMINARY



Mechanical Dimensions

All Dimensions In Inches(mm)
 Tolerances Inches: X.XX= ±0.02 , X.XXX= ±0.010
 Millimeters: X.X= ±0.5 , X.XX=±0.25

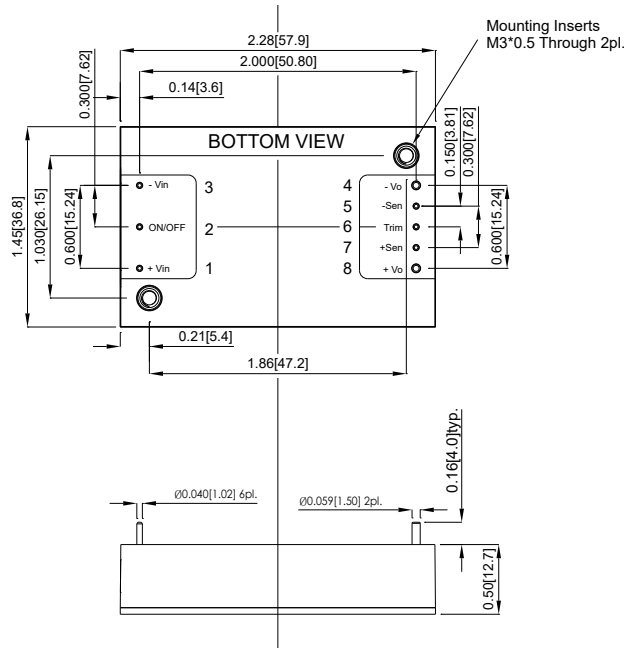

PIN CONNECTION	
PIN	Function
1	+V Input
2	On/Off
3	-V Input
4	-V Output
5	-Sense
6	Trim
7	+Sense
8	+V Output

MODEL NUMBER	INPUT VOLTAGE	OUTPUT VOLTAGE	OUTPUT CURRENT		INPUT CURRENT		% EFF.		CAPACITOR LOAD MAX.
			MIN.	MAX.	NO LOAD	FULL LOAD	(1)	(2)	
CQB75W8-36S12	9-75 VDC	12 VDC	0 mA	6.25 A	10 mA	2367 mA	88	88	6250µF
CQB75W8-36S15	9-75 VDC	15 VDC	0 mA	5.0 A	10 mA	2341 mA	89	89	5000µF
CQB75W8-36S24	9-75 VDC	24 VDC	0 mA	3.12 A	10 mA	2311 mA	90	90	3120µF
CQB75W8-36S28	9-75 VDC	28 VDC	0 mA	2.67 A	10 mA	2307 mA	90	90	2670µF
CQB75W8-36S48	9-75 VDC	48 VDC	0 mA	1.56 A	10 mA	2311 mA	90	90	1560µF

NOTE:
 1. Nominal Input Voltage 36 VDC
 2. Measured at 48Vin
 3. An External Input Capacitor 220uF for All Models are Recommended to Reduce Input Ripple Voltag

Remote On/Off Control

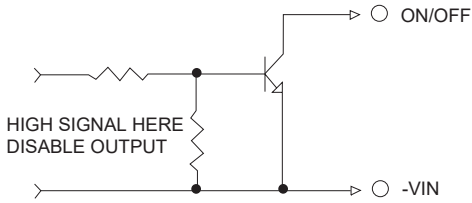

External Output Trim

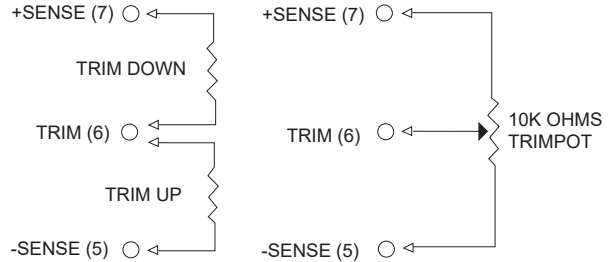

Specifications

All Specifications Typical At Nominal Line, Full Load, and 25°C Unless Otherwise Noted

INPUT SPECIFICATIONS

Input Voltage Range	36V 9-75V
Input Surge Voltage (100ms max.)	100Vdc max.
Under voltage lockout	power up 8.8V power down 8.0V
Positive Logic Remote On/Off	See note 4 & 5
Input Filter (note 7)	PI Type

OUTPUT SPECIFICATIONS

Voltage Accuracy	±1.0% max.
Transient Response: 25% Step Load Change	
Error Band	±5% Vout nominal
Recovery Time	<250us
External Trim Adj. Range	-20%, +15%
Ripple & Noise, 20MHz BW (note 3)	
12V & 15V	80mV RMS, 150mV pk-pk max.
24V & 28V	120mV RMS, 240mV pk-pk max.
48V	220mV RMS, 480mV pk-pk max.
Temperature Coefficient	±0.02%/°C max.
Short Circuit Protection	Continuous
Line Regulation (note 1)	±0.2% max.
Load Regulation (note 2)	±0.2% max.
Over Voltage Protection trip Range, % Vo nom.	115-140%
Current Limit	110%-200% Nominal Output
Start up time	30ms typ.

GENERAL SPECIFICATIONS

Efficiency	See Table
Isolation Voltage	Input/Output 3000VAC min. Input/Case 2700VDC min. Output/Case 1600VDC min.
Isolation Resistance	10 ⁸ ohm min.
Isolation Capacitance	1000pF typ
Switching Frequency	200KHz typ.
Operating Case Temperature	-40°C to 105°C
Storage Temperature	-55°C to +125°C
Thermal Shutdown, Case Temp.	110°C typ.
Humidity	95% RH max. Non condensing
MTBF ...MIL-HDBK-217F, GB, 25°C, Full Load	TBD.
Safety	Meet UL62368 (Reinforced Insulation)
EMC (note 8)	Meet EN50155 (EN50121-3-2) with External Filter Meet EN50155 (EN61373) Meet EN50155(EN60068-2-1,2,30) Meet EN45545-2
Shock/Vibration	2.28 x 1.45 x 0.50 inches (57.9 x 36.8 x 12.7 mm)
Environmental	Aluminum Baseplate with Plastic Case
Fire & Smoke	61.5 g
Dimensions	
Case Material	
Weight	

NOTE

1. Measured from high line to low line.
2. Measured from full load to zero load.
3. Output ripple and noise measured with 22uF aluminum solid capacitor and 1uF ceramic capacitor across output.
4. Logic compatibility open collector ref to -Input
Module on > 3.5VDC to 75VDC or open circuit
Module off 0 to <1.2 VDC
5. Suffix "N" to the model number with negative logic remote on/off
Module on 0 to <1.2 VDC
Module off >3.5VDC to 75VDC or open circuit
6. Suffix "-C" to the model number with clear mounting insert (3.2mm DIA.)
7. An external input capacitor 220uF for all models are recommended to reduce input ripple voltage
8. For information about EN50155 and RIA12, refer to application note.

CQB100W SERIES

100 WATT, 4:1 INPUT RANGE

Features

- ◆ 100W Isolated Output
- ◆ Quarter-Brick Package
- ◆ 4 : 1 Input Range
- ◆ Efficiency to 88%
- ◆ Regulated Output
- ◆ Input Under Voltage Protection
- ◆ Over Temperature Protection
- ◆ Over Voltage/Current Protection
- ◆ Remote On/Off
- ◆ 1500VDC Isolation
- ◆ Safety Meets UL60950-1



Mechanical Dimensions

All Dimensions in Inches (mm)
 Tolerance Inches: X.XX±0.02, X.XXX±0.010
 Millimeters: X.X±0.5, X.XX±0.25

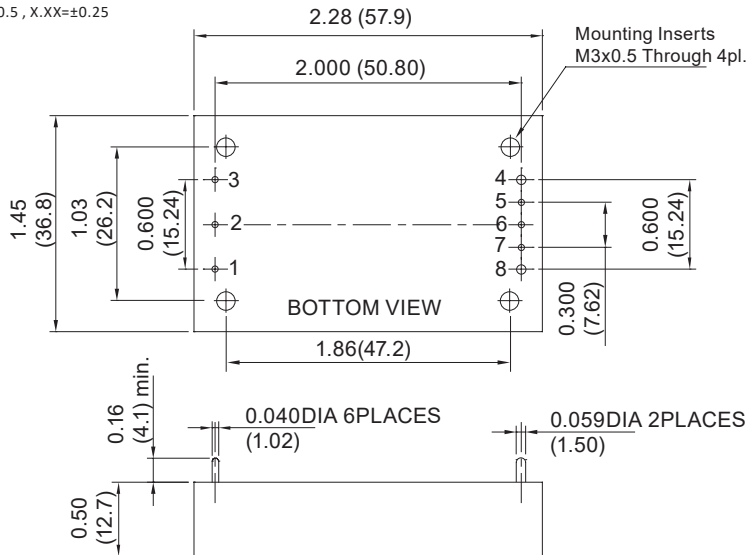

PIN CONNECTION	
PIN	Function
1	+V Input
2	On/Off
3	-V Input
4	-V Output
5	-Sense
6	Trim
7	+Sense
8	+V Output

MODEL NUMBER	INPUT VOLTAGE	OUTPUT VOLTAGE	OUTPUT CURRENT		INPUT CURRENT		% EFF.	CAPACITOR LOAD MAX.
			MIN.	MAX.	NO LOAD	FULL LOAD		
CQB100W-24S3V3	9-36 VDC	3.3VDC	0 mA	30 A	120 mA	4797 mA	86	10000µF
CQB100W-24S05	9-36 VDC	5 VDC	0 mA	20 A	120 mA	4817 mA	86.5	10000µF
CQB100W-24S12	9-36 VDC	12 VDC	0 mA	8.3 A	80 mA	4798 mA	86.5	2200µF
CQB100W-24S15	9-36 VDC	15 VDC	0 mA	6.7 A	80 mA	4841 mA	86.5	2200µF
CQB100W-24S24	9-36 VDC	24 VDC	0 mA	4.17 A	80 mA	4793 mA	87	2200µF
CQB100W-48S3V3	18-75 VDC	3.3 VDC	0 mA	30 A	60 mA	2344 mA	88	10000µF
CQB100W-48S05	18-75 VDC	5 VDC	0 mA	20 A	60 mA	2367 mA	88	10000µF
CQB100W-48S12	18-75 VDC	12 VDC	0 mA	8.3 A	30 mA	2358 mA	88	2200µF
CQB100W-48S15	18-75 VDC	15 VDC	0 mA	6.7 A	30 mA	2379 mA	88	2200µF
CQB100W-48S24	18-75 VDC	24 VDC	0 mA	4.17 A	30 mA	2369 mA	88	2200µF

External Output Trim

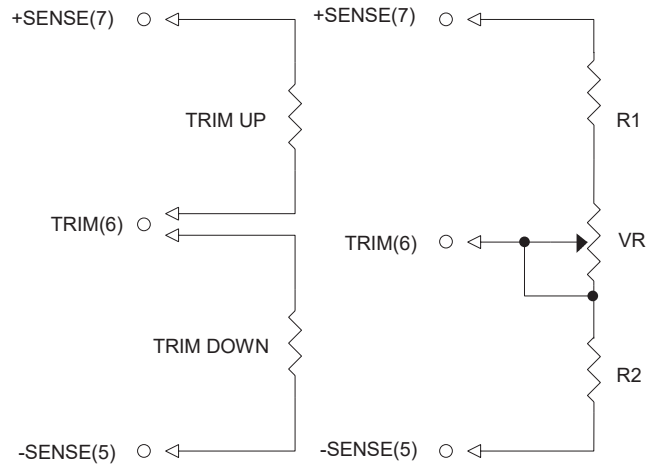

Specifications

All Specifications Typical At Nominal Line, Full Load, and 25°C Unless Otherwise Noted

INPUT SPECIFICATIONS

Input Voltage Range	24V	9-36V	
	48V	18-75V	
Input Surge Voltage (100ms max.)	24V	50Vdc max.	
	48V	100Vdc max.	
Under voltage lockout	24Vin	power up	8.8V typ.
		power down	8V typ.
	48Vin	power up	17V typ.
		power down	16V typ.
Input Filter		Pi Type	
Positive Logic Remote On/Off		See note 4 & 5	

OUTPUT SPECIFICATIONS

Voltage Accuracy	±1.0% max.
Transient Response: 75% to 100% Step Load Change	
Error Band	3.3V±7% Vout, Others±5% Vout
Recover Time	< 500µs
External Trim Adj. Range (note 6)	±10%
Ripple and Noise, 20MHz BW (see note 3)	
3.3V & 5V	40mV RMS, 100mV pk-pk max.
12V & 15V	60mV RMS, 150mV pk-pk max.
24V	100mV RMS, 240mV pk-pk max.
Temperature Coefficient	±0.03%/°C max.
Short Circuit Protection	Continuous
Line Regulation (note 1)	±0.2% max.
Load Regulation (note 2)	±0.2% max.
Over Voltage Protection Trip Range, %Vo nom.	115-140%
Current Limit	110%-160% Nominal Output
Start up time	120ms typ.

GENERAL SPECIFICATIONS

Efficiency	See Table
Isolation Voltage	Input/Output..... 1500VDC min. Input/Case..... 1500VDC min. Output/Case..... 1500VDC min.
Isolation Resistance	10 ⁷ Ohms min.
Isolation Capacitance	1000pF typ.
Switching Frequency	48Vin 250KHz typ. 24Vin 220KHz typ.
Operating Case Temperature	-40°C to 100°C
Storage Temperature Range	-40°C to +105°C
Thermal Shutdown, Case Temp.	110°C typ.
Dimensions	1.45 x 2.28 x 0.50 inches (36.8 x 57.9 x 12.7 mm)
Humidity	95% RH max. Non condensing
MTBF MIL-STD-217F, GB, 25°C, Full Load	600Khrs typ.
Case Material	Aluminum Base-plate with Plastic Case
Weight	66 g

NOTE

- Measured from high line to low line.
- Measured from full load to min. load.
- The output noise is measured with 10µF tantalum capacitor and 1µF ceramic capacitor across output.
- Logic compatibility open collector ref to -Input
Module On >3.5VDC to 75VDC or open circuit
Module Off < 1.2VDC
- Suffix "N" to the model number with negative logic remote On/Off
Module On < 1.2VDC
Module Off >3.5VDC to 75VDC or Open Circuit
- Trim-up connect a resistor between the trim pin and +Sense
Trim-down connect a resistor between the trim pin and -Sense
- Suffix "-C" to the model number with clear mounting insert(3.2mm DIA.)
- An external input capacitor 47µF for 48Vin models and 100µF for 24Vin models are recommended to reduce input ripple voltage.

CQB100-110S SERIES

100 WATT, INPUT RANGE 66-160 VDC

Features

- ◆ 100W Isolated Output
- ◆ Efficiency to 93%
- ◆ 200KHz Switching Frequency
- ◆ 3 : 1 Input Range
- ◆ Regulated Outputs
- ◆ Remote On/Off
- ◆ Over Temperature Protection
- ◆ Over Voltage/Current Protection
- ◆ Continuous Short Circuit Protection
- ◆ Quarter Brick Size Meets Industrial Standard
- ◆ UL60950-1 Approval (Except 3.3 Vout)
- ◆ Meets EN50155



Mechanical Dimensions

All Dimensions in Inches (mm)
 Tolerance Inches: X.XX=±0.02, X.XXX=±0.010
 Millimeters: X.X=±0.5, X.XX=±0.25

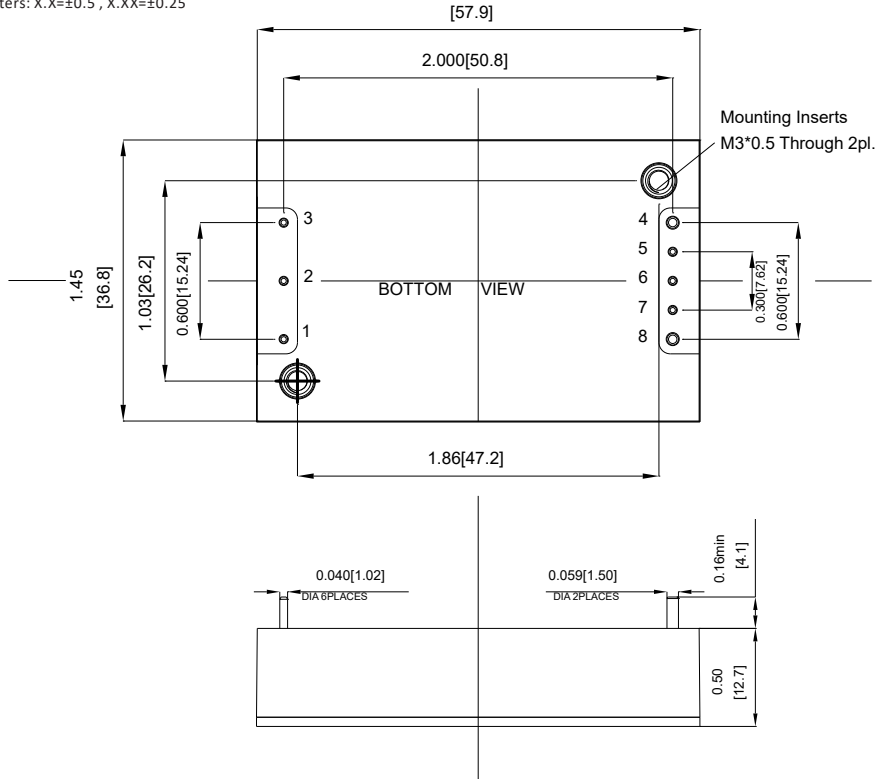

PIN CONNECTION	
PIN	Function
1	+V Input
2	On/Off
3	-V Input
4	-V Output
5	-Sense
6	Trim
7	+Sense
8	+V Output

MODEL NUMBER	INPUT VOLTAGE	OUTPUT VOLTAGE	OUTPUT CURRENT		INPUT CURRENT		% EFF.	CAPACITOR LOAD MAX.
			MIN.	MAX.	NO LOAD	FULL LOAD		
CQB100-110S3V3	66-160 VDC	3.3 VDC	0 mA	25 A	40 mA	833 mA	90	10000µF
CQB100-110S05	66-160 VDC	5.0 VDC	0 mA	20 A	30 mA	983 mA	92.5	10000µF
CQB100-110S12	66-160 VDC	12 VDC	0 mA	8.4 A	40 mA	985 mA	93	8800µF
CQB100-110S24	66-160 VDC	24 VDC	0 mA	4.2 A	60 mA	996 mA	92	1500µF

External Output Trim

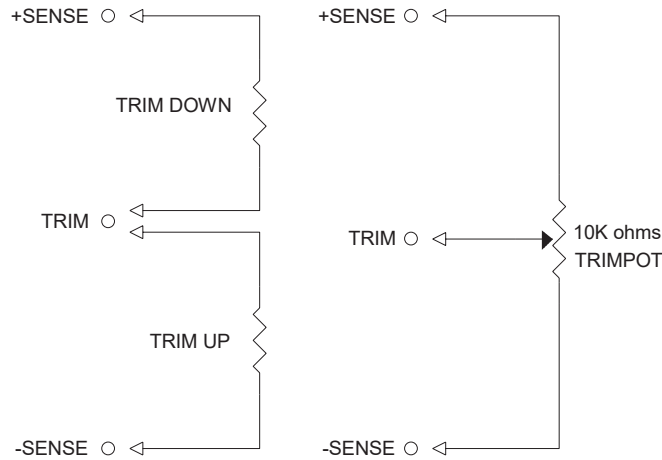

Specifications

All Specifications Typical At Nominal Line, Full Load, and 25°C Unless Otherwise Noted

INPUT SPECIFICATIONS

Input Voltage Range	110V, 66-160V
Input Surge Voltage (100ms max.)	180Vdc max.
Under Voltage Lockout	power up 62V power down 56V
Positive Logic Remote On/Off:	
Logic Compatibility	Open Collector ref. to -Input
Module On	> 3.5Vdc to 75Vdc or Open
Module Off	< 1.8Vdc
Input Filter	Pi Type

OUTPUT SPECIFICATIONS

Voltage Accuracy	±1.0% max. 3.3V:±1.5% max
Transient Response:	
25% Step Load Change	< 200µs
External Trim Adj. Range	±10%
Ripple & Noise, 20MHz BW (note 3)	
3.3 & 5V	40mV RMS, 100mV pk-pk max.
12V	60mV RMS, 150mV pk-pk max.
24V	100mV RMS, 240mV pk-pk max.
Temperature Coefficient	±0.03%/°C
Short Circuit Protection	Continuous
Line Regulation (note 1)	±0.2% max.
Load Regulation (note 2)	±0.2% max.
Over Voltage Protection Trip Range, % Vo nom.	115-140%
Current Limit	110%-180% Nominal Output
Start up time	45ms typ.

NOTE

1. Measured from high line to low line.
2. Measured from full load to zero load.
3. Output ripple and noise measured with 10µF tantalum and 1µF ceramic capacitor across output.
4. Suffix "N" to the model number with negative logic remote On/Off

Module On	< 1.8VDC
Module Off	> 3.5VDC to 75VDC or open circuit

GENERAL SPECIFICATIONS

Efficiency	See Table
Isolation Voltage	Input/Output 2250VDC min. Input/Case 2250VDC min. Output/Case 1500VDC min.
Isolation Resistance	10 ⁷ ohm min.
Isolation Capacitance	1000pF typ.
Switching Frequency	200KHz typ.
Operating Case Temperature	-40°C to 100°C
Storage Temperature	-55°C to +105°C
Thermal Shutdown Case Temp.	105°C typ.
Humidity	95% RH max. Non condensing
MTBF MIL-HDBK-217F, GB, 25°C, Full Load	XXS3V3:400Khrs typ XXS05:240Khrs typ. Others :320Khrs typ.
Safety (Except 3.3 Vout)	UL60950-1 2 nd (Basic insulation), Approval
EMC (note 7)	Meet EN50155 (EN50121-3-2) with External Filter
Shock/Vibration	Meet EN50155 (EN61373)
Environmental	Meet EN50155 (EN60068-2-1)
Dimensions	2.28 x 1.45 x 0.50 inches (57.9 x 36.8 x 12.7 mm)
Case Material	Aluminum Baseplate with Plastic Case
Weight	61.5 g

5. Suffix "-C" to the model number with clear mounting insert (3.2mm DIA.)
6. An external input capacitor 120µF for all models are recommended to reduce input ripple voltage.
7. Design meet EN50155 and RIA12 refer to application note.

CQB100W-110S SERIES

100 WATT 4:1 INPUT DC-DC CONVERTERS SINGLE OUTPUT

Features

- ◆ 100W Isolated Output
- ◆ Efficiency up to 92%
- ◆ Fixed Switching Frequency
- ◆ 4:1 Input Range
- ◆ Regulated Outputs
- ◆ Remote On/Off
- ◆ Low No Load Power Consumption
- ◆ Over Temperature Protection
- ◆ Over Voltage/Current Protection
- ◆ Continuous Short Circuit Protection
- ◆ Quarter Brick Size Meet Industrial Standard
- ◆ UL60950-1 2nd(Basic Insulation) Approval
- ◆ CB Test Certificate IEC60950-1
- ◆ Meets EN50155 with External Circuits
- ◆ Shock & Vibration Meet EN50155 (EN61373)
- ◆ Fire & Smoke Meet EN45545-2
- ◆ 3000m Operating Altitude



Mechanical Dimensions

All Dimensions In Inches(mm)
Tolerances Inches: X.XX= ±0.02 , X.XXX= ±0.010
Millimeters: X.X= ±0.5 , X.XX=±0.25

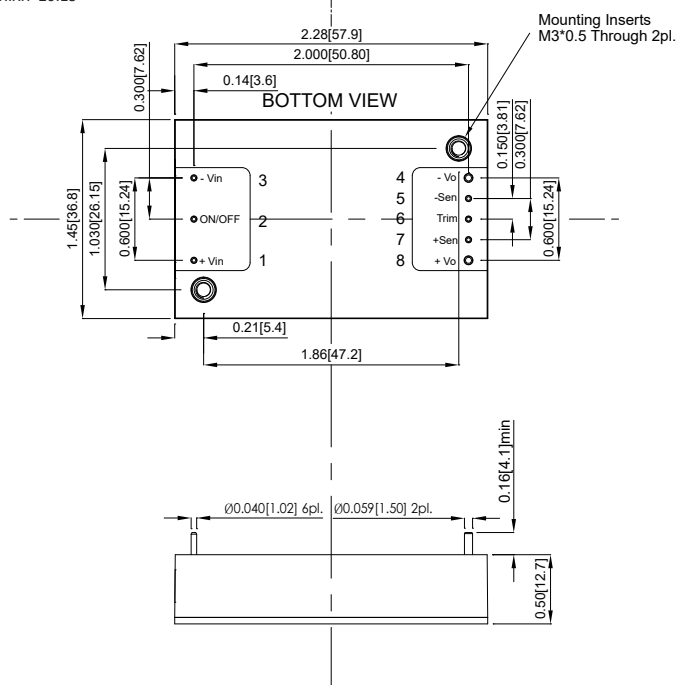

PIN CONNECTION	
PIN	Function
1	+V Input
2	On/Off
3	-V Input
4	-V Output
5	-Sense
6	Trim
7	+Sense
8	+V Output

MODEL NUMBER	INPUT VOLTAGE	OUTPUT VOLTAGE	OUTPUT CURRENT		INPUT CURRENT		% EFF.	CAPACITOR LOAD MAX.
			MIN.	MAX.	NO LOAD	FULL LOAD		
CQB100W-110S05	43-160 VDC	5 VDC	0 mA	20 A	10 mA	1.00A	91	20000µF
CQB100W-110S12	43-160 VDC	12 VDC	0 mA	8.4 A	10 mA	1.00A	92	8400µF
CQB100W-110S24	43-160 VDC	24 VDC	0 mA	4.2 A	10 mA	1.03A	89	4200µF
CQB100W-110S28	43-160 VDC	28 VDC	0 mA	3.6 A	10 mA	1.04A	88.5	3600µF
CQB100W-110S48	43-160 VDC	48 VDC	0 mA	2.1 A	10 mA	1.02A	90	1000µF

NOTE:
1. Nominal Input Voltage 110VDC
2. An external input capacitor 220µF for all models are recommended to reduce input ripple voltage.

Remote On/Off Control

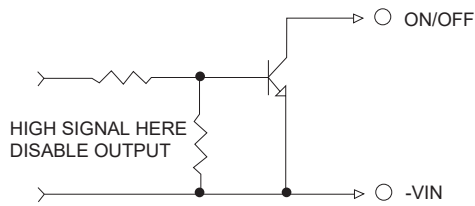

External Output Trim

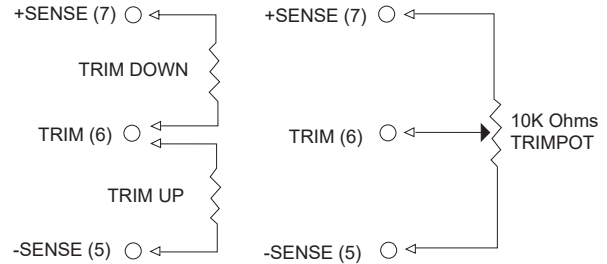

Specifications

All Specifications Typical At Nominal Line, Full Load, and 25°C Unless Otherwise Noted

INPUT SPECIFICATIONS

Input Voltage Range	110V	43-160V
Input Surge Voltage (100ms max.) Under voltage lockout	110V	200Vdc max. power up 41.5V power down 38V
Positive Logic Remote On/Off		See note 4 & 5
Input Filter(note 7)		PI Type

OUTPUT SPECIFICATIONS

Voltage Accuracy	±1.0% max.
Transient Response:75%-100% Step Load Change	
Error Band	±5% Vout nominal
Recovery Time	<250us
External Trim Adj. Range	±10%
Ripple & Noise, 20MHz BW (see note 3)	
5V	40mV RMS, 100mV pk-pk max.
12V	60mV RMS, 150mV pk-pk max.
24V&28V	100mV RMS, 280mV pk-pk max.
48V	200mV RMS, 480mV pk-pk max.
Temperature Coefficient	±0.02%/°C
Short Circuit Protection	Continuous
Line Regulation (note 1)	±0.2% max.
Load Regulation (note 2)	±0.2% max.
Over Voltage Protection trip Range, % Vo nom.	115-140%
Current Limit	110%-160% Nominal
	Output
Start up time	60ms typ.

GENERAL SPECIFICATIONS

Efficiency	See Table
Isolation Voltage	Input/Output 3000VDC min. Input/Case 2250VDC min. Output/Case 500VAC min. 10 ⁸ ohm min.
Isolation Resistance	1500pF typ
Isolation Capacitance	300KHz typ.
Switching Frequency	-40°C to 105°C
Operating Case Temperature	-55°C to +125°C
Storage Temperature	110°C typ.
Thermal Shutdown, Case Temp.	95% RH max. Non condensing
Humidity	
MTBF ... MIL-STD-217F, GB, 25°C, Full Load	
	5V/12V 720Khrs typ. Others 840Khrs typ. UL60950-1 2 nd (Basic Insulation) EN50155(EN50121-3-2) with External Filter EN50155(EN61373) EN50155(EN60068-2-1) Meet EN45545-2 2.28 x 1.45 x 0.50 inches (57.9 x 36.8 x 12.7 mm)
Safety	
EMC (note 8)	
Shock/Vibration	
Environmental	
Fire & Smoke	
Dimensions	
Case Material	Aluminum Base Plate with Plastic Case
Weight	68 g

NOTE

1. Measured from high line to low line.
2. Measured from full load to zero load.
3. Output ripple and noise measured with 10uF aluminum and 1uF ceramic capacitor across output for 48Vout and with 10uF tantalum and 1uF ceramic capacitor for others.
4. Logic compatibility open collector ref to -Input
Module on >3.5Vdc to 160Vdc or open circuit
Module off 0 to < 1.2Vdc
5. Suffix "N" to the model number with negative logic remote on/off
Module on 0 to < 1.2Vdc
Module off >3.5Vdc to 160Vdc or open circuit
6. Suffix "-C" to the model number with clear mounting insert (3.2mm DIA.).
7. An external input capacitor 220uF for all models are recommended to reduce input ripple voltage.
8. For information about EN50155 and RIA12, refer to application note.

CQB150W SERIES

150 WATT, 4:1 INPUT RANGE

Features

- ◆ 150W Isolated Output
- ◆ Efficiency to 92%
- ◆ Fixed Switching Frequency
- ◆ 4 : 1 Input Range
- ◆ Regulated Outputs
- ◆ Remote On/Off
- ◆ Low No Load Power Consumption
- ◆ Over Temperature Protection
- ◆ Over Voltage/Current Protection
- ◆ Continuous Short Circuit Protection
- ◆ Quarter Brick Size Meets Industrial Standard
- ◆ UL60950-1 2nd Approval
- ◆ CB Test Certificate IEC60950-1
- ◆ Meets EN50155 with External Circuits
- ◆ Shock & Vibration Meets EN50155 (EN61373)
- ◆ Fire & Smoke Meets EN45545-2
- ◆ 3000m Operating Altitude



Mechanical Dimensions

All Dimensions in Inches (mm)
 Tolerance Inches: X.XX=±0.02, X.XXX=±0.010
 Millimeters: X.X=±0.5, X.XX=±0.25

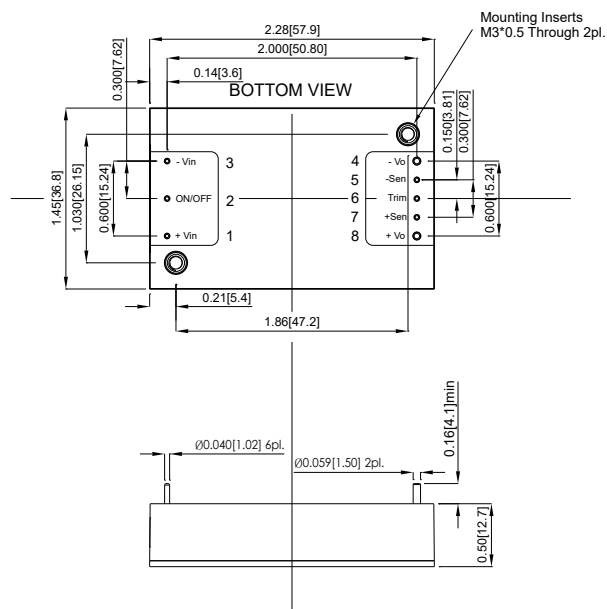

PIN CONNECTION	
PIN	Function
1	+V Input
2	On/Off
3	-V Input
4	-V Output
5	-Sense
6	Trim
7	+Sense
8	+V Output

MODEL NUMBER	INPUT VOLTAGE	OUTPUT VOLTAGE	OUTPUT CURRENT		INPUT CURRENT		% EFF.		CAPACITOR LOAD MAX.
			MIN.	MAX.	NO LOAD	FULL LOAD	(3)	(2)	
CQB150W-24S05	9-36 VDC	5 VDC	0 mA	30 A	10 mA	7.02 A	91	92	30000µF
CQB150W-24S12	9-36 VDC	12 VDC	0 mA	12.5 A	10 mA	7.02 A	91	92	12500µF
CQB150W-24S24	9-36 VDC	24 VDC	0 mA	6.3 A	10 mA	7.08 A	89.5	89.5	6300µF
CQB150W-24S28	9-36 VDC	28 VDC	0 mA	5.4 A	10 mA	7.08 A	90	90	5400µF
CQB150W-24S48	9-36 VDC	48 VDC	0 mA	3.2 A	10 mA	7.19 A	90.5	90.5	1000µF
CQB150W-48S05	18-75 VDC	5 VDC	0 mA	30 A	8 mA	3.47 A	92	92	30000µF
CQB150W-48S12	18-75 VDC	12 VDC	0 mA	12.5 A	8 mA	3.47 A	92	91	12500µF
CQB150W-48S24	18-75 VDC	24 VDC	0 mA	6.3 A	8 mA	3.50 A	91	90.5	6300µF
CQB150W-48S28	18-75 VDC	28 VDC	0 mA	5.4 A	8 mA	3.50 A	91.5	90.5	5400µF
CQB150W-48S48	18-75 VDC	48 VDC	0 mA	3.2 A	8 mA	3.56 A	92	91.5	1000µF

NOTE:

1. Nominal Input Voltage 24, 48 VDC
2. Measured at Nominal Input Voltage
3. Measured at 12VDC for 24Vin, 24VDC for 48Vin

Remote On/Off Control

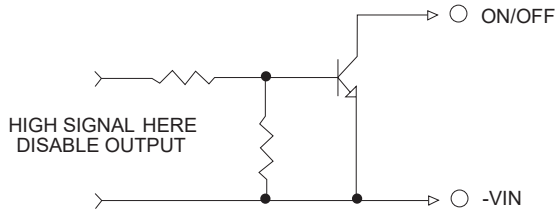

External Output Trim

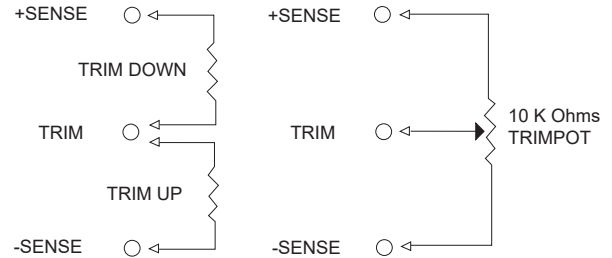

Specifications

All Specifications Typical At Nominal Line, Full Load, and 25°C Unless Otherwise Noted

INPUT SPECIFICATIONS

Input Voltage Range	24V	9-36V
	48V	18-75V
Input Surge Voltage (100ms max.)	24V	50Vdc max.
	48V	100Vdc max.
Under voltage lockout	24Vin	power up 8.8V
		power down 8.0V
	48Vin	power up 17V
		power down 16V
Positive Logic Remote On/Off Input Filter (note 7)		see note 4 & 5 PI Type

OUTPUT SPECIFICATIONS

Voltage Accuracy:	±1.0% max
Transient Response: 75% to 100% Step Load Change	
Error Band	±5% Vout Recover
Recover Time	250us
External Trim Adj. Range	±10%
Ripple & Noise, 20MHz BW	
5V	40mV RMS, 100mV pk-pk max.
12V	60mV RMS, 150mV pk-pk max.
24V & 28V	100mV RMS, 280mV pk-pk max.
48V	200mV RMS, 480mV pk-pk max.
Temperature Coefficient	±0.02%/°C
Short Circuit Protection	Continuous
Line Regulation (note 1)	±0.2% max.
Load Regulation (note 2)	±0.2% max.
Over Voltage Protection trip Range, % Vo nom.	115-140%
Current Limit	110%-160% Nominal Output
Start up time	60ms typ.

GENERAL SPECIFICATIONS

Efficiency	See Table
Isolation Voltage :	
CQB150W-24SXX and CQB150W-48SXX:	Input/Output 2250VDCmin.
	Input/Case 2250VDCmin.
	Output/Case 2250VDCmin.
Isolation Resistance	10 ⁸ ohm min.
Isolation Capacitance	1500pF typ.
Switching Frequency	300KHz typ.
Operating Ambient Temperature	-40°C to +105°C
Storage Temperature	-55°C to +105°C
Thermal Shutdown, Case Temperature	110°C typ.
Humidity	95% RH max. Non condensing
Shock/Vibration	Meet MIL-STD-810F/EN6137
Dimensions	2.28 × 1.45 × 0.50 inches (57.9 × 36.8 × 12.7 mm)
Case Material	Aluminum Baseplate with Plastic Case
Weight	68 g

NOTE

1. Measured from high line to low line.
2. Measured from full load to zero load.
3. Output ripple and noise measured with 10µF aluminum and 1µF ceramic capacitor across output for 48Vout and with 10µF tantalum and 1µF ceramic capacitor for others.
4. Logic compatibility open collector ref to -Input
Module On >3.5VDC to 75VDC or open circuit
Module Off 0 to < 1.2Vdc
5. Suffix "N" to the model number with negative logic remote On/Off
Module On 0 to < 1.2Vdc
Module Off >3.5VDC to 75VDC or open circuit
6. Suffix "-C" to the model number with clear mounting insert (3.2mm DIA.)
7. An external input capacitor 220µF for all models are recommended to reduce input ripple voltage.

CQB150W-110S SERIES

150 WATT, INPUT RANGE 43-160 VDC

Features

- ◆ 150W Isolated Output
- ◆ Efficiency to 92%
- ◆ Fixed Switching Frequency
- ◆ 4 : 1 Input Range
- ◆ Regulated Outputs
- ◆ Remote On/Off
- ◆ Low No Load Power Consumption
- ◆ Over Temperature Protection
- ◆ Over Voltage/Current Protection
- ◆ Continuous Short Circuit Protection
- ◆ Quarter Brick Size Meets Industrial Standard
- ◆ UL60950-1 2nd (Basic Insulation) Approval
- ◆ CB Test Certificate IEC60950-1
- ◆ Meets EN50155 with External Circuits
- ◆ Shock & Vibration Meets EN50155 (EN61373)
- ◆ Fire & Smoke Meets EN45545-2
- ◆ 3000m Operating Altitude



Mechanical Dimensions

All Dimensions in Inches (mm)
 Tolerance Inches: X.XX=±0.02, X.XXX=±0.010
 Millimeters: X.X=±0.5, X.XX=±0.25

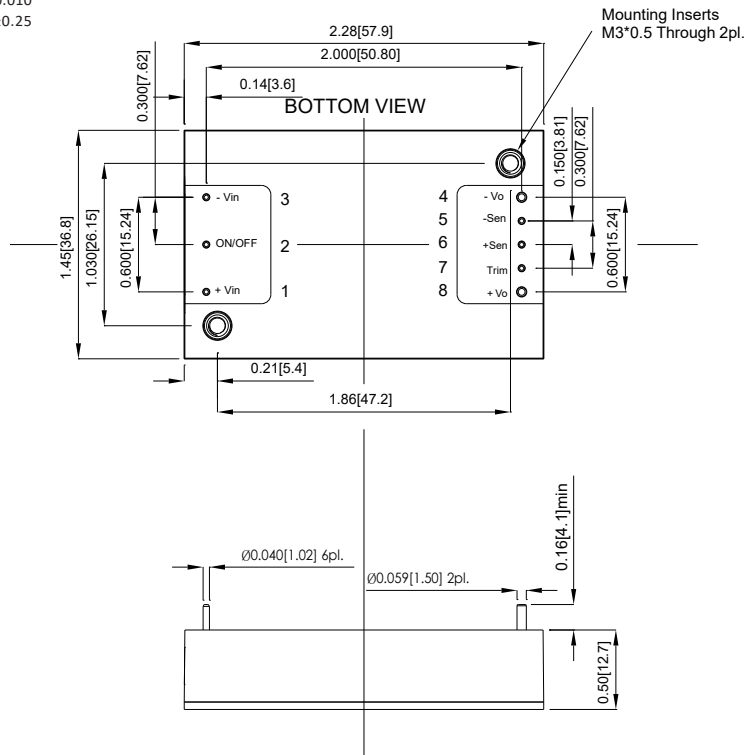

MODEL NUMBER	INPUT VOLTAGE	OUTPUT VOLTAGE	OUTPUT CURRENT		INPUT CURRENT		% EFF.	CAPACITOR LOAD MAX.
			MIN.	MAX.	NO LOAD	FULL LOAD		
CQB150W-110S05	43-160 VDC	5 VDC	0 mA	30 A	10 mA	1.50 A	91	30000µF
CQB150W-110S12	43-160 VDC	12 VDC	0 mA	12.5 A	10 mA	1.48 A	92	12500µF
CQB150W-110S24	43-160 VDC	24 VDC	0 mA	6.3 A	10 mA	1.54 A	89	6300µF
CQB150W-110S28	43-160 VDC	28 VDC	0 mA	5.4 A	10 mA	1.54 A	89	5400µF
CQB150W-110S48	43-160 VDC	48 VDC	0 mA	3.2 A	10 mA	1.54 A	90.5	1000µF

Remote On/Off Control

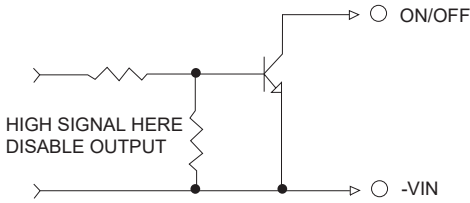

External Output Trim

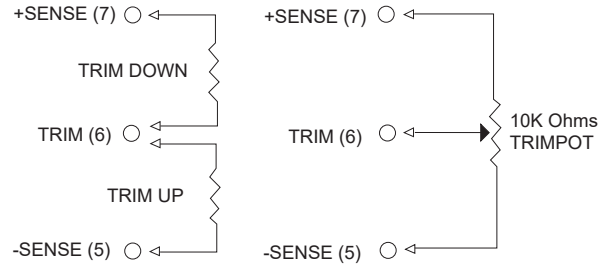

Specifications

All Specifications Typical At Nominal Line, Full Load, and 25°C Unless Otherwise Noted

INPUT SPECIFICATIONS

Input Voltage Range	110V, 43-160V
Input Surge Voltage (100ms max.)	110V, 200Vdc max.
Under voltage lockout	110V _{in} power up 41.5V 110V _{in} power down 38V
Positive Logic Remote On/Off (see note 4 & 5)	
Input Filter(note 7)	PI Type

OUTPUT SPECIFICATIONS

Voltage Accuracy:	±1.0% max.
Transient Response: 25% Step Load Change	< 250µs
External Trim Adj. Range	±10%
Ripple & Noise, 20MHz BW	
5V	40mV RMS, 100mV pk-pk max.
12V	60mV RMS, 150mV pk-pk max.
24V & 28V	100mV RMS, 280mV pk-pk max.
48V	200mV RMS, 480mV pk-pkmax.
Temperature Coefficient	±0.02%/°C max.
Short Circuit Protection	Continuous
Line Regulation (note 1)	±0.2% max.
Load Regulation (note 2)	±0.2% max.
Over Voltage Protection trip Range, % Vo nom.	115-140%
Current Limit	110%-160% Nominal Output
Start up time	60ms typ.

GENERAL SPECIFICATIONS

Efficiency	See Table
Isolation Voltage :	Input/Output3000VDC min. Input/Case 2250VDC min. Output/Case 500VDC min.
Isolation Resistance	10 ⁸ ohm min.
Isolation Capacitance	1500pF typ.
Switching Frequency	300KHz typ.
Operating Ambient Temperature	-40°C to +105°C
Storage Temperature	-55°C to +105°C
Thermal Shutdown, Case Temperature	110°C typ.
Humidity	95% RH max. Non condensing
MTBF	MIL-HDBK-217F, GB, 25°C, Full Load 5V/12V:720Khrs typ. Others:840Khrs typ.
Dimensions	2.28 × 1.45 × 0.50 inches (57.9 × 36.8 × 12.7 mm)
Safety	UL60950-1 2 nd (Basic Insulation)
EMC (note 8)	EN50155 (EN50121-3-2) with External Filter
Shock/Vibration	EN50155 (EN61373)
Environmental	EN50155 (EN60068-2-1)
Case Material	Aluminum Base Plate with Plastic Case
Weight	68 g

NOTE

- Measured from high line to low line.
- Measured from full load to zero load.
- Output ripple and noise measured with 10µF tantalum and 1µF ceramic capacitor across output for 48Vout and with 10µF tantalum and 1µF ceramic capacitor for others.
- Logic compatibility open collector ref to -Input
Module On >3.5Vdc to 160Vdc or open circuit
Module Off 0 to < 1.2Vdc
- Suffix "N" to the Model Number with Negative Logic Remote On/Off
Module On 0 to < 1.2Vdc
Module Off >3.5Vdc to 160Vdc or Open Circuit
- Suffix "-C" to the Model Number with Clear Mounting Insert (3.2mm DIA.)
- An external input capacitor 220µF for all models are recommended to reduce input ripple voltage
- For information about EN50155 and RIA12, refer to application note.

CQB150-300S SERIES

150 WATT, INPUT RANGE 180-425 VDC

Features

- ◆ 150W Isolated Output
- ◆ Efficiency to 89%
- ◆ Fixed Switching Frequency
- ◆ Regulated Outputs
- ◆ Remote On/Off
- ◆ Low No Load Power Consumption
- ◆ Over Temperature Protection
- ◆ Over Voltage/Current Protection
- ◆ Continuous Short Circuit Protection
- ◆ Quarter Brick Size meets Industrial Standard
- ◆ UL60950-1 2nd (Reinforced Insulation) Approval
- ◆ CB Test Certificate IEC60950-1
- ◆ Shock & Vibration Meets EN50155 (EN61373)
- ◆ Fire & Smoke Meets EN45545-2



Mechanical Dimensions

All Dimensions in Inches (mm)
 Tolerance Inches: X.XX±0.02, X.XXX±0.010
 Millimeters: X.X±0.5, X.XX±0.25

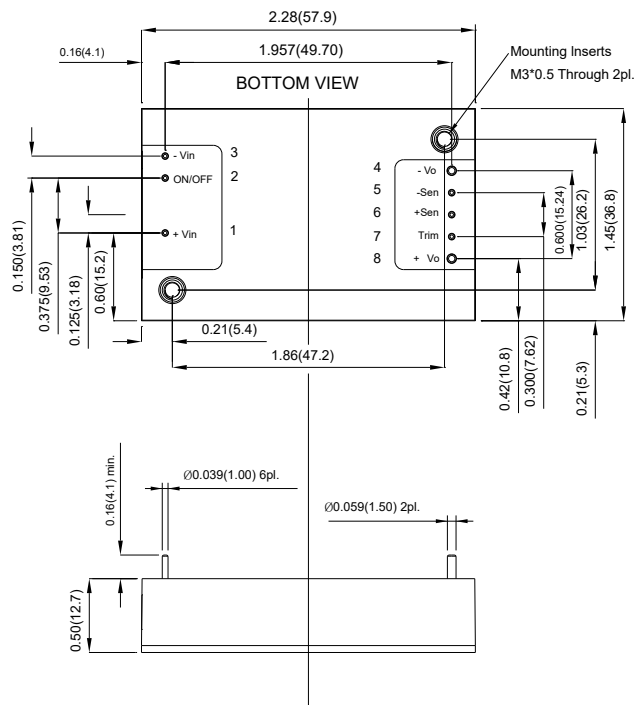

PIN CONNECTION	
PIN	Function
1	+V Input
2	On/Off
3	-V Input
4	-V Output
5	-Sense
6	Trim
7	+Sense
8	+V Output

MODEL NUMBER	INPUT VOLTAGE	OUTPUT VOLTAGE	OUTPUT CURRENT		INPUT CURRENT		% EFF.	CAPACITOR LOAD MAX.
			MIN.	MAX.	NO LOAD	FULL LOAD		
CQB150-300S05	180-425 VDC	5 VDC	0 mA	30 A	10 mA	580 mA	86	10000µF
CQB150-300S12	180-425 VDC	12 VDC	0 mA	12.5 A	10 mA	560 mA	89	8800µF
CQB150-300S15	180-425 VDC	15 VDC	0 mA	10 A	10 mA	560 mA	89	8800µF
CQB150-300S24	180-425 VDC	24 VDC	0 mA	6.3 A	10 mA	570 mA	88.5	3300µF
CQB150-300S28	180-425 VDC	28 VDC	0 mA	5.4 A	10 mA	570 mA	88.5	3300µF
CQB150-300S48	180-425 VDC	48 VDC	0 mA	3.2 A	10 mA	570 mA	89	1000µF

NOTE:

1. Nominal Input Voltage 300 VDC.
2. Require a Ceramic Capacitor 2200pF Connected Between -Vin to Case for All Models.
3. An External Input Capacitor 180µF for All Models are Recommended to Reduce Input Ripple Voltage.
4. Measure at Nominal Input Voltage.

Remote On/Off Control

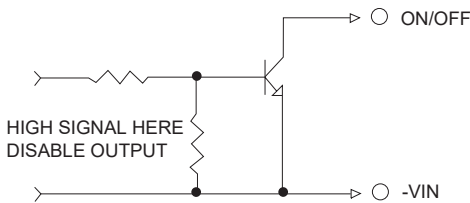

External Output Trim

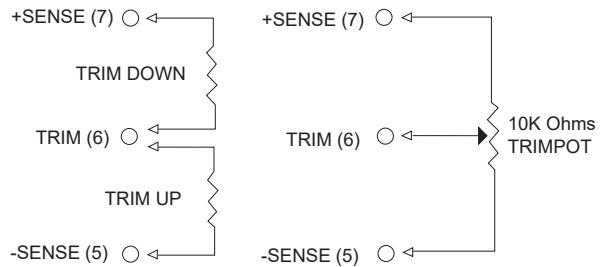

Specifications

All Specifications Typical At Nominal Line, Full Load, and 25°C Unless Otherwise Noted

INPUT SPECIFICATIONS

Input Voltage Range	300V..... 180-425V
Input over voltage protection	Module on.....440V typ. Module off.....450V typ.
Under voltage lockout	300Vin power up 170V 300Vin power down.....160V
Positive Logic Remote On/Off	See note 4 & 5
Input Filter(note 7)	PI Type

OUTPUT SPECIFICATIONS

Voltage Accuracy:	±1.0% max.
Transient Response: 25% Step Load Change	<250us
External Trim Adj. Range	+10%, -20%
Ripple & Noise, 20MHz BW	
5V	60mV RMS, 100mV pk-pk, max.
12V & 15V	60mV RMS, 150mV pk-pk max.
24V & 28V	100mV RMS, 280mV pk-pk max.
48V	200mV RMS, 480mV pk-pk max.
Temperature Coefficient	±0.02%/°C
Short Circuit Protection	Continuous
Line Regulation (note 1)	±0.2% max.
Load Regulation (note 2)	±0.2% max.
Over Voltage Protection trip Range ,% Vo nom.	115-140%
Current Limit	110%-160% Nominal Output
Start up time	280ms typ.

GENERAL SPECIFICATIONS

Efficiency	See Table
Isolation Voltage :	
Isolation Voltage	Input/Output.....3000VAC min. Input/Case..... 2500VAC min. Output/Case.....500VAC min.
Isolation Resistance	10 ⁸ ohm min.
Switching Frequency	360KHz typ.
Operating Ambient Temperature	-40°C to +105°C
Storage Temperature	-55°C to +105°C
Thermal Shutdown, Case Temperature	110°C typ.
Humidity	95% RH max. Non condensing MIL-HDBK-217F, GB, 25°C, Full Load
MTBF	48V:1000Khrs typ. Others:800Khrs typ.
Dimensions	2.2 8× 1.45 x 0.50 inches (57.9 x 36.8 × 12.7 mm)
Case Material	Aluminum Base Plate with Plastic Case
Weight	65 g

NOTE

- Measured from high line to low line.
- Measured from full load to zero load.
- Output ripple and noise measured with 10µF tantalum and 1µF ceramic capacitor across output for 48Vout and with 10µF tantalum and 1µF ceramic capacitor for others.
- Logic compatibility open collector ref to -Input
Module On >3.5VDC to 75VDC or open circuit
Module Off 0 to <1.2Vdc
- Suffix "N" to the model number with negative logic remote On/Off
Module On0 to <1.2Vdc
Module Off >3.5Vdc to 75Vdc or Open Circuit
- Suffix "-C" to the model number with clear mounting insert (3.2mm DIA.)
- An external input capacitor 180µF for all models are recommended to reduce input ripple voltage.
- Require a disc ceramic capacitor 2200pF (type KX Class X1 Y1 series Murata) connected between -vin to case for all models.

CHB50 SERIES

33-50 WATT

Features

- ◆ 33W-50W Isolated Output
- ◆ Efficiency to 89%
- ◆ 300/400KHz Switching Frequency
- ◆ 2 : 1 Input Range
- ◆ Regulated Outputs
- ◆ Continuous Short Circuit Protection
- ◆ Five-Sided Metal Case
- ◆ Half-Brick Size Meet Industrial Standard
- ◆ Safety Meets UL60950-1, EN60950-1 and IEC60950-1
- ◆ UL60950-1 Approval

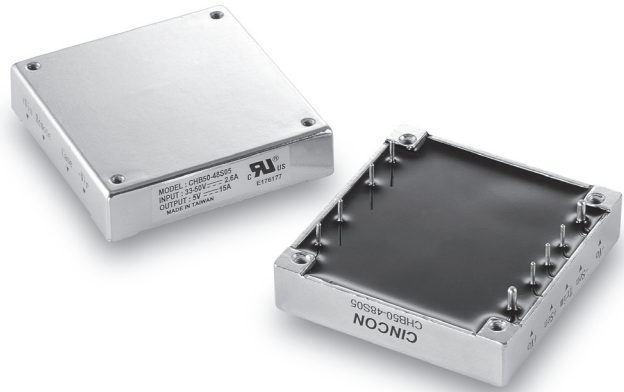

Mechanical Dimensions

All Dimensions in Inches (mm)
 Tolerance Inches: X.XX=±0.02, X.XXX=±0.010
 Millimeters: X.X=±0.5, X.XX=±0.25

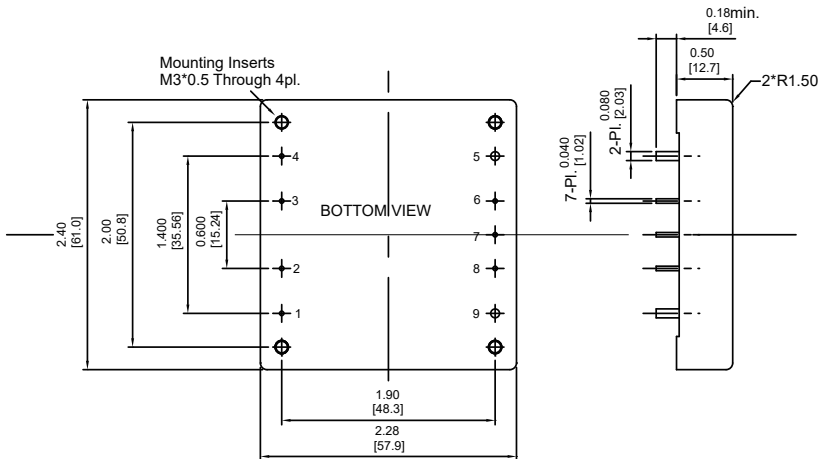

PIN CONNECTION	
PIN 1	+V Input
PIN 2	On/Off
PIN 3	Case
PIN 4	-V Input
PIN 5	-V Output
PIN 6	-Sense
PIN 7	Trim
PIN 8	+Sense
PIN 9	+V Output

MODEL NUMBER	INPUT VOLTAGE	OUTPUT VOLTAGE	OUTPUT CURRENT		INPUT CURRENT		% EFF.	CAPACITOR LOAD MAX.
			MIN.	MAX.	NO LOAD	FULL LOAD		
CHB50-12S33	9 -18 VDC	3.3 VDC	0 mA	10 A	50 mA	3481 mA	79	10000µF
CHB50-12S05	9 -18 VDC	5 VDC	0 mA	10 A	50 mA	5020 mA	83	10000µF
CHB50-12S12	9 -18 VDC	12 VDC	0 mA	4.16 A	50 mA	4781 mA	87	4000µF
CHB50-12S15	9 -18 VDC	15 VDC	0 mA	3.33 A	50 mA	4781 mA	87	2000µF
CHB50-12S24	9 -18 VDC	24 VDC	0 mA	2.08 A	50 mA	4781 mA	87	1500µF
CHB50-24S33	18-36 VDC	3.3 VDC	0 mA	10 A	50 mA	1698 mA	81	10000µF
CHB50-24S05	18-36 VDC	5 VDC	0 mA	10 A	50 mA	2450 mA	85	10000µF
CHB50-24S12	18-36 VDC	12 VDC	0 mA	4.16 A	50 mA	2363 mA	88	10000µF
CHB50-24S15	18-36 VDC	15 VDC	0 mA	3.33 A	50 mA	2363 mA	88	4000µF
CHB50-24S24	18-36 VDC	24 VDC	0 mA	2.08 A	50 mA	2363 mA	88	2000µF
CHB50-48S33	36-75 VDC	3.3 VDC	0 mA	10 A	50 mA	848 mA	81	10000µF
CHB50-48S05	36-75 VDC	5 VDC	0 mA	10 A	50 mA	1240 mA	84	10000µF
CHB50-48S12	36-75 VDC	12 VDC	0 mA	4.16 A	50 mA	1181 mA	88	10000µF
CHB50-48S15	36-75 VDC	15 VDC	0 mA	3.33 A	50 mA	1181 mA	88	4000µF
CHB50-48S24	36-75 VDC	24 VDC	0 mA	2.08 A	50 mA	1168 mA	89	2000µF

Remote On/Off Control

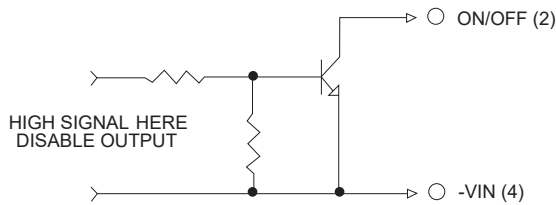

External Output Trim

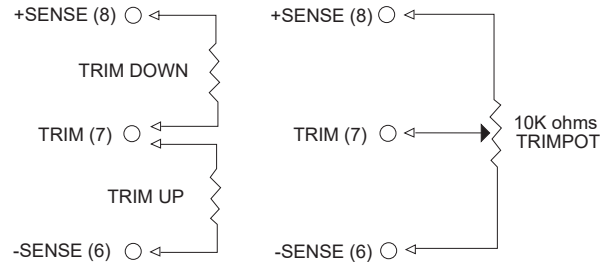

Specifications

All Specifications Typical At Nominal Line, Full Load, and 25°C Unless Otherwise Noted

INPUT SPECIFICATIONS

Input Voltage Range	12V 9-18V	24V 18-36V	48V 36-75V
Input Surge Voltage (100ms max.)	12V 25Vdc max.	24V 50Vdc max.	48V 100Vdc max.
Under Voltage Lockout:			
12Vin	power up >8.8V	power down >8V	
24Vin	power up >17V	power down >16V	
48Vin	power up >34V	power down >32.5V	
Positive Logic Remote On/Off Input Filter	See note 3 & 4	Pi Type	

OUTPUT SPECIFICATIONS

Voltage Accuracy	±1.0% max.
Transient Response: 25% Step Load Change	< 500µs
External Trim Adj. Range °C	±10%/°C
Ripple & Noise, 20MHz BW(see note 5)	
3.3V & 5V	20mV RMS max. 75mV pk-pk max.
12V & 15V	30mV RMS max. 100mV pk-pk max.
24V	100mV RMS max. 240mV pk-pk max.
Temperature Coefficient	±0.03%/°C
Short Circuit Protection Line	Continuous
Regulation (see note 1) Load	±0.2% max.
Regulation (see note 2)	±0.2% max.
Over Voltage Protection Trip Range, % Vo nom.	115-140%
Current Limit	110%-150% Nominal Output
Start up time	5ms typ.

GENERAL SPECIFICATIONS

Efficiency	See Table
Isolation Voltage	Input/Output 1500VDC min. Input/Case 1500VDC min. Output/Case 1500VDC min.
Isolation Capacitance	1000pF typ.
Isolation Resistance	10 ⁷ ohm min.
Switching Frequency	(12/24)Vin 400KHz typ. 48Vin 300KHz typ.
Operating Case Temperature	-40°C to 100°C
Storage Temperature	-55°C to +105°C
Thermal Shutdown Case Temp.	100°C typ.
Humidity	95% RH max. Non condensing
MTBFMIL-STD-217F, GB, 25°C, Full Load	1000Khrs typ.
Dimensions	2.28 × 2.40 × 0.50 inches (57.9 × 61.0 × 12.7 mm)
Case Material	Aluminum
Weight	88 g

NOTE

1. Measured from high line to low line.
2. Measured from full load to zero load.
3. Logic compatibility open collector ref to -Input
 Module On open circuit
 Module Off < 0.8VDC
4. Suffix "N" to the model number with negative logic remote On/Off.
5. Output ripple and noise measured with 10µF tantalum and 1µF ceramic capacitor across output.
6. Suffix "-C" to the model number with clear mounting Insert (3.2mm DIA.)
7. ON/OFF Pin is not directly applied voltage, please refer to remote on / off control circuit.

CHB50W SERIES

33-50 WATT, 4:1 INPUT RANGE

Features

- ◆ 33W-50W Isolated Output
- ◆ Efficiency to 87%
- ◆ 300KHz Switching Frequency
- ◆ 4 : 1 Input Range
- ◆ Regulated Outputs
- ◆ Continuous Short Circuit Protection
- ◆ Five-Sided Shield Metal Case
- ◆ Half-Brick Size Meet Industrial Standard
- ◆ CE Mark Meets 2004/108/EC
- ◆ UL60950-1 Approval (Except 28 Vout)
- ◆ Safety Meets UL60950-1, EN60950-1 and IEC60950-1

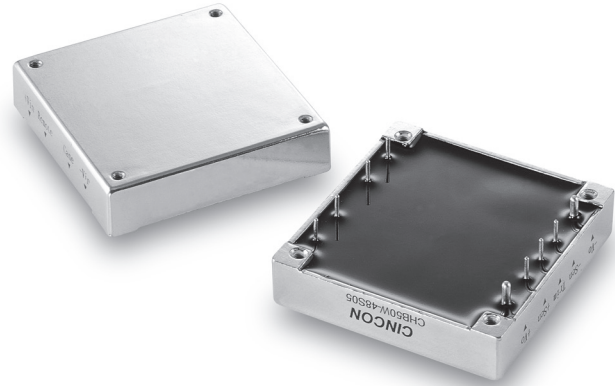

Mechanical Dimensions

All Dimensions in Inches (mm)
 Tolerance Inches: X.XX±0.02, X.XXX±0.010
 Millimeters: X.X±0.5, X.XX±0.25

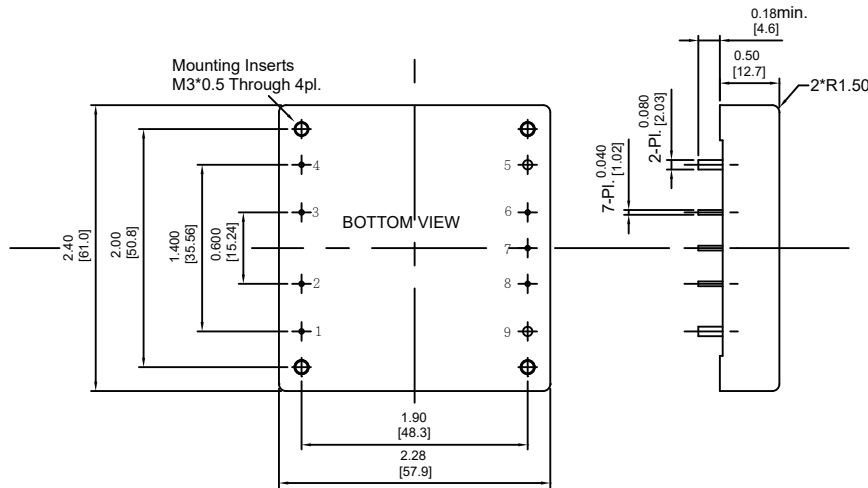

PIN CONNECTION	
PIN	Function
1	+V Input
2	On/Off
3	Case
4	-V Input
5	-V Output
6	-Sense
7	Trim
8	+Sense
9	+V Output

MODEL NUMBER	INPUT VOLTAGE	OUTPUT VOLTAGE	OUTPUT CURRENT		INPUT CURRENT		% EFF.	CAPACITOR LOAD MAX.
			MIN.	MAX.	NO LOAD	FULL LOAD		
CHB50W-24S33	9-36 VDC	3.3 VDC	0 mA	10 A	50 mA	1740 mA	79	10000µF
CHB50W-24S05	9-36 VDC	5 VDC	0 mA	10 A	50 mA	2570 mA	81	10000µF
CHB50W-24S12	9-36 VDC	12 VDC	0 mA	4.16 A	50 mA	2510 mA	83	4160µF
CHB50W-24S15	9-36 VDC	15 VDC	0 mA	3.33 A	50 mA	2448 mA	85	3330µF
CHB50W-24S24	9-36 VDC	24 VDC	0 mA	2.08 A	50 mA	2476 mA	84	2080µF
CHB50W-24S28	9-36 VDC	28 VDC	0 mA	1.78 A	50 mA	2510 mA	83	1780µF
CHB50W-24S48	9-36 VDC	48 VDC	0 mA	1.04 A	50 mA	2506 mA	83	1040µF
CHB50W-48S33	18-75 VDC	3.3 VDC	0 mA	10 A	50 mA	848 mA	81	10000µF
CHB50W-48S05	18-75 VDC	5 VDC	0 mA	10 A	50 mA	1255 mA	83	10000µF
CHB50W-48S12	18-75 VDC	12 VDC	0 mA	4.16 A	50 mA	1223 mA	85	4160µF
CHB50W-48S15	18-75 VDC	15 VDC	0 mA	3.33 A	50 mA	1196 mA	87	3330µF
CHB50W-48S24	18-75 VDC	24 VDC	0 mA	2.08 A	50 mA	1209 mA	86	2080µF
CHB50W-48S28	18-75 VDC	28 VDC	0 mA	1.78 A	50 mA	1223 mA	85	1780µF
CHB50W-48S48	18-75 VDC	48 VDC	0 mA	1.04 A	50 mA	1238 mA	84	1040µF

NOTE: 1. Nominal Input Voltage 24, 48VDC

Remote On/Off Control

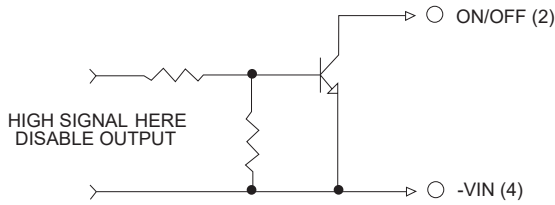

External Output Trim

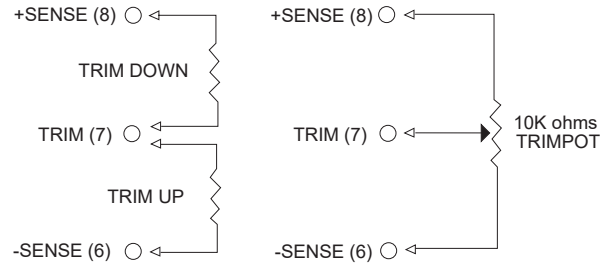

Specifications

All Specifications Typical At Nominal Line, Full Load, and 25°C Unless Otherwise Noted

INPUT SPECIFICATIONS

Input Voltage Range	24V 9-36V	48V 18-75V
Input Surge Voltage (100ms max.)	24V 50Vdc max.	48V 100Vdc max.
Under Voltage Lockout:		
24Vin	power up 8.8V	power down 8V
48Vin	power up 17V	power down 16V
Positive Logic Remote On/Off	See note 3 & 4	
Input Filter	Pi Type	

OUTPUT SPECIFICATIONS

Voltage Accuracy (note 7)	±1.0% max.
Transient Response: 25% Step Load Change	< 500µs
External Trim Adj. Range	±10%
Ripple & Noise, 20MHz BW (note 5)	
3.3V & 5V	40mV RMS max., 100mV pk-pk max.
12V & 15V	60mV RMS max., 150mV pk-pk max.
24V	100mV RMS max., 240mV pk-pk max.
28V	100mV RMS max., 280mV pk-pk max.
48V	200mV RMS max., 480mV pk-pk max.
Temperature Coefficient	±0.03%/°C
Short Circuit Protection	Continuous
Line Regulation (note 1 & 7)	±0.2% max.
Load Regulation (note 2 & 7)	±0.2% max.
Over Voltage Protection Trip Range, % Vo nom.	115-140%
Current Limit	110% -160% Nominal Output
Start up time	5ms typ.

GENERAL SPECIFICATIONS

Efficiency	See Table
Isolation Voltage	nput/Output..... 1500VDC min. Input/Case..... 1500VDC min. Output/Case 1500VDC min.
Isolation Resistance	10 ⁷ ohm min.
Isolation Capacitance	1000pF typ.
Switching Frequency	300KHz typ.
Operating Case Temperature	-40°C to 100°C
Storage Temperature	-55°C to +105°C
Thermal Shutdown Case Temp.	100°C typ.
Humidity	95% RH max. Non condensing
MTBF MIL-STD-217F, GB, 25°C, Full Load	1000Khrs typ.
Dimensions	2.28 x 2.40 x 0.50 inches (57.9 x 61.0 x 12.7 mm)
Case Material	Aluminum
Weight	94 g

NOTE

- Measured from high line to low line.
- Measured from full load to zero load.
- Logic compatibility open collector ref to -input
Module On >3.5VDC to 75VDC or open circuit
Module Off < 0.8VDC
- Suffix "N" to the model number with negative logic remote On/Off.
Module On < 0.8VDC
Module Off >3.5VDC to 75VDC or open circuit
- Output ripple and noise measured with 10µF tantalum and 1µF ceramic capacitor across output. (48V: 1µF ceramic cap. only)
- Suffix "-C" to the model number with clear mounting insert (3.2mm DIA.)
- Require a 47µF aluminum capacitor connected between +Vout and -Vout for 48Vout models.

CHB75 SERIES

49.5-75 WATT

Features

- ◆ 49.5W-75W Isolated Output
- ◆ Efficiency to 89%
- ◆ 300/400KHz Switching Frequency
- ◆ 2 : 1 Input Range
- ◆ Regulated Outputs
- ◆ Continuous Short Circuit Protection
- ◆ Five-Sided Metal Case
- ◆ Half-Brick Size Meet Industrial Standard
- ◆ Safety Meets UL60950-1, EN60950-1 and IEC60950-1
- ◆ UL60950-1 Approval



Mechanical Dimensions

All Dimensions in Inches (mm)
 Tolerance Inches: X.XX=±0.02 , X.XXX=±0.010
 Millimeters: X.X=±0.5 , X.XX=±0.25

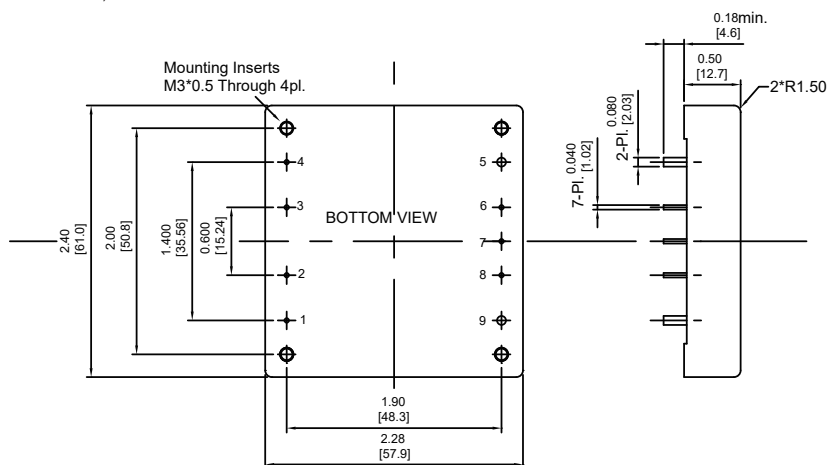

PIN CONNECTION	
PIN	Function
1	+V Input
2	On/Off
3	Case
4	-V Input
5	-V Output
6	-Sense
7	Trim
8	+Sense
9	+V Output

MODEL NUMBER	INPUT VOLTAGE	OUTPUT VOLTAGE	OUTPUT CURRENT		INPUT CURRENT		% EFF.	CAPACITOR LOAD MAX.
			MIN.	MAX.	NO LOAD	FULL LOAD		
CHB75-12S33	9 -18 VDC	3.3 VDC	0 mA	15 A	50 mA	5290 mA	78	10000µF
CHB75-12S05	9 -18 VDC	5 VDC	0 mA	15 A	50 mA	7530 mA	83	10000µF
CHB75-12S12	9 -18 VDC	12 VDC	0 mA	6.25 A	50 mA	7183 mA	87	10000µF
CHB75-12S15	9 -18 VDC	15 VDC	0 mA	5 A	50 mA	7267 mA	86	4000µF
CHB75-12S24	9 -18 VDC	24 VDC	0 mA	3.13 A	50 mA	7183 mA	87	2000µF
CHB75-24S33	18-36 VDC	3.3 VDC	0 mA	15 A	50 mA	2578 mA	80	10000µF
CHB75-24S05	18-36 VDC	5 VDC	0 mA	15 A	50 mA	3720 mA	84	10000µF
CHB75-24S12	18-36 VDC	12 VDC	0 mA	6.25 A	50 mA	3551 mA	88	10000µF
CHB75-24S15	18-36 VDC	15 VDC	0 mA	5 A	50 mA	3551 mA	88	4000µF
CHB75-24S24	18-36 VDC	24 VDC	0 mA	3.13 A	50 mA	3551 mA	88	2000µF
CHB75-48S33	36-75 VDC	3.3 VDC	0 mA	15 A	50 mA	1273 mA	81	10000µF
CHB75-48S05	36-75 VDC	5 VDC	0 mA	15 A	50 mA	1860 mA	84	10000µF
CHB75-48S12	36-75 VDC	12 VDC	0 mA	6.25 A	50 mA	1755 mA	89	10000µF
CHB75-48S15	36-75 VDC	15 VDC	0 mA	5 A	50 mA	1775 mA	88	4000µF
CHB75-48S24	36-75 VDC	24 VDC	0 mA	3.13 A	50 mA	1755 mA	89	2000µF

NOTE: 1. Nominal Input Voltage 12, 24 or 48VDC

Remote On/Off Control

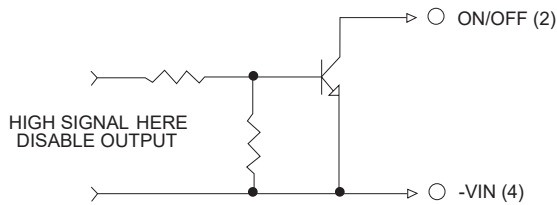

External Output Trim

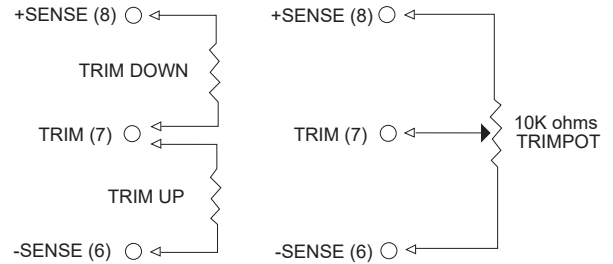

Specifications

All Specifications Typical At Nominal Line, Full Load, and 25°C Unless Otherwise Noted

INPUT SPECIFICATIONS

Input Voltage Range	12V 9-18V	24V 18-36V	48V 36-75V
Input Surge Voltage (100ms max.)	12V 25Vdc max.	24V 50Vdc max.	48V 100Vdc max.
Under Voltage Lockout :			
12Vin	power up >8.8V	power down >8V	
24Vin	power up >17V	power down >16V	
48Vin	power up >34V	power down >32.5V	
Positive Logic Remote On/Off	See note 3 & 4		
Input Filter	Pi Type		

OUTPUT SPECIFICATIONS

Voltage Accuracy	±1.0% max.
Transient Response:25% Step Load Change	< 500µs.
External Trim Adj. Range	±10 %
Ripple & Noise, 20MHz BW (see note 5)	
3.3V & 5V	20mV RMS max. 75mV pk-pk max.
12V & 15V	30mV RMS max. 100mV pk-pk max.
24V	100mV RMS max. 240mV pk-pk max.
Temperature Coefficient	±0.03%/°C
Short Circuit Protection	Continuous
Line Regulation (see note1)	±0.2% max.
Load Regulation (see note2)	±0.2% max.
Over Voltage Protection Trip Range, % Vo nom.	115-140%
Current Limit	110%-150% Nominal Output
Start up time	5ms typ.

GENERAL SPECIFICATIONS

Efficiency	See Table
Isolation Voltage	Input/Output 1500VDC min. Input/Case 1500VDC min. Output/Case 1500VDC min. 10 ⁷ ohm min.
Isolation Resistance	1000pF typ.
Isolation Capacitance	(12/24)Vin 400KHz typ. 48Vin 300KHz typ.
Switching Frequency	-40°C to 100°C
Operating Case Temperature	-55°C to +105°C
Storage Temperature	100°C typ.
Thermal Shutdown Case Temp.	95% RH max. Non condensing
Humidity	1000Khrs typ.
MTBF MIL-STD-217F, GB, 25°C, Full Load	2.28 × 2.40 × 0.50 inches (57.9 × 61.0 × 12.7 mm)
Dimensions	Aluminum
Case Material	92 g
Weight	

NOTE

1. Measured from high line to low line.
2. Measured from full load to zero load.
3. Logic compatibility open collector ref to -Input
 Module On open circuit
 Module Off < 0.8VDC
4. Suffix "N" to the model number with negative logic remote on/off.
5. Output ripple and noise measured with 10µF tantalum and 1µF ceramic capacitor across output.
6. Suffix "-C" to the model number with clear mounting Insert (3.2mm DIA.)
7. On/Off Pin is not directly applied voltage, please refer to remote On / Off control circuit.

CHB75W SERIES

49.5-75 WATT, 4:1 INPUT RANGE

Features

- ◆ 49.5W-75W Isolated Output
- ◆ Efficiency to 85%
- ◆ 300KHz Switching Frequency
- ◆ 4 : 1 Wide Input Range
- ◆ Regulated Outputs
- ◆ Continuous Short Circuit Protection
- ◆ Five-Sided Metal Case
- ◆ Half-Brick Size Meet Industrial Standard
- ◆ Safety Meets UL60950-1, EN60950-1, and IEC60950-1
- ◆ UL60950-1 Approval (Except 28 Vout)

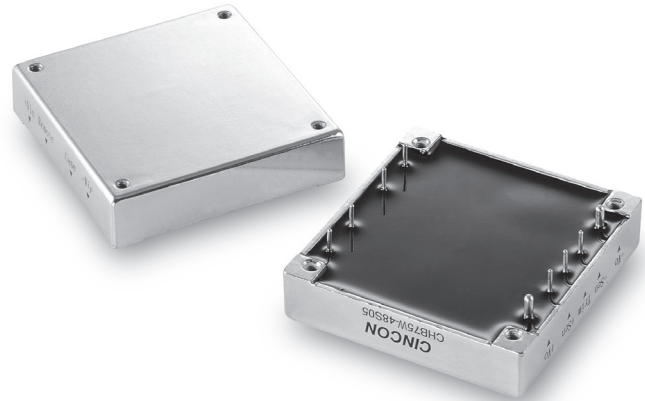

Mechanical Dimensions

All Dimensions in Inches (mm)
 Tolerance Inches: X.XX=±0.02, X.XXX=±0.010
 Millimeters: X.X=±0.5, X.XX=±0.25

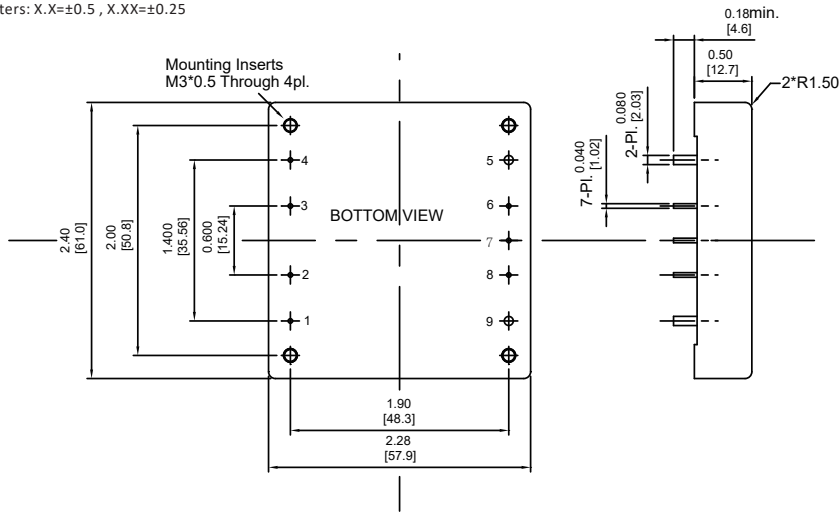

PIN CONNECTION	
PIN	Function
1	+V Input
2	On/Off
3	Case
4	-V Input
5	-V Output
6	-Sense
7	Trim
8	+Sense
9	+V Output

MODEL NUMBER	INPUT VOLTAGE	OUTPUT VOLTAGE	OUTPUT CURRENT		INPUT CURRENT		% EFF.	CAPACITOR LOAD MAX.
			MIN.	MAX.	NO LOAD	FULL LOAD		
CHB75W-24S33	9-36 VDC	3.3 VDC	0 mA	15 A	50 mA	2611 mA	79	15000µF
CHB75W-24S05	9-36 VDC	5 VDC	0 mA	15 A	50 mA	3811 mA	82	15000µF
CHB75W-24S12	9-36 VDC	12 VDC	0 mA	6.25 A	50 mA	3765 mA	83	6250µF
CHB75W-24S15	9-36 VDC	15 VDC	0 mA	5 A	50 mA	3720 mA	84	5000µF
CHB75W-24S24	9-36 VDC	24 VDC	0 mA	3.12 A	50 mA	3720 mA	84	3120µF
CHB75W-24S28	9-36 VDC	28 VDC	0 mA	2.67 A	50 mA	3720 mA	84	2670µF
CHB75W-24S48	9-36 VDC	48 VDC	0 mA	1.56 A	50 mA	3811 mA	82	1560µF
CHB75W-48S33	18-75 VDC	3.3 VDC	0 mA	15 A	50 mA	1289 mA	80	15000µF
CHB75W-48S05	18-75 VDC	5 VDC	0 mA	15 A	50 mA	1883 mA	83	15000µF
CHB75W-48S12	18-75 VDC	12 VDC	0 mA	6.25 A	50 mA	1860 mA	84	6250µF
CHB75W-48S15	18-75 VDC	15 VDC	0 mA	5 A	50 mA	1838 mA	85	5000µF
CHB75W-48S24	18-75 VDC	24 VDC	0 mA	3.12 A	50 mA	1835 mA	85	3120µF
CHB75W-48S28	18-75 VDC	28 VDC	0 mA	2.67 A	50 mA	1835 mA	85	2670µF
CHB75W-48S48	18-75 VDC	48 VDC	0 mA	1.56 A	50 mA	1860 mA	84	1560µF

NOTE: 1. Nominal Input Voltage 24, 48VDC

Remote On/Off Control

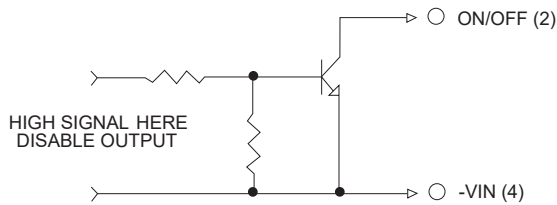

External Output Trim

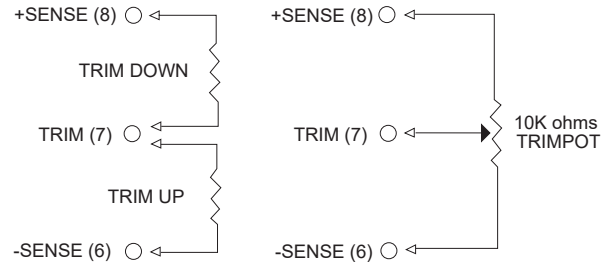

Specifications

All Specifications Typical At Nominal Line, Full Load, and 25°C Unless Otherwise Noted

INPUT SPECIFICATIONS

Input Voltage Range	24V	9-36V
	48V	18-75V
Input Surge Voltage (100ms max.)	24V	50Vdc max.
	48V	100Vdc max.
Under Voltage Lockout	24Vin	power up 8.8V
		power down 8.0V
	48Vin	power up 17V
		power down 16V
Positive Logic Remote On/Off		See note 3 & 4
Input Filter		Pi Type

OUTPUT SPECIFICATIONS

Voltage Accuracy	±1.0% max.
Transient Response: 25% Step Load Change	< 500µs
External Trim Adj. Range	±10%
Ripple & Noise, 20MHz BW (see note 5)	
3.3V & 5V	40mV RMS max., 100mV pk-pk max.
12V & 15V	60mV RMS max., 150mV pk-pk max.
24V	100mV RMS max., 240mV pk-pk max.
28V	100mV RMS max., 280mV pk-pk max.
48V	200mV RMS max., 480mV pk-pk max.
Temperature Coefficient	±0.03%/°C
Short Circuit Protection	Continuous
Line Regulation (note 1& 7)	±0.2% max.
Load Regulation (note 2& 7)	±0.2% max.
Over Voltage Protection Trip Range, % Vo nom.	115-140%
Current Limit	110%-160% Nominal Output
Start up time	5ms typ.

GENERAL SPECIFICATIONS

Efficiency	See Table
Isolation Voltage	Input/Output 1500VDC min.
	Input/Case..... 1500VDC min.
	Output/Case 1500VDC min.
	10 ⁷ ohm min.
Isolation Resistance	1000pF typ.
Isolation Capacitance	300KHz typ.
Switching Frequency	-40°C to 100°C
Operating Case Temperature	-55°C to +105°C
Storage Temperature	100°C typ.
Thermal Shutdown Case Temp.	95% RH max. Non condensing
Humidity	1000Khrs typ.
MTBF MIL-STD-217F, GB, 25°C, Full Load	2.28 x 2.40 x 0.50 inches
Dimensions	(57.9 x 61.0 x 12.7 mm)
	Aluminum
Case Material	94 g
Weight	

NOTE

- Measured from high line to low line.
- Measured from full load to zero load.
- Logic compatibility open collector ref to -input
Module On >3.5VDC to 75VDC or open circuit
Module Off < 0.8VDC
- Suffix "N" to the model number with negative logic remote on/off
Module On < 0.8VDC
Module Off >3.5VDC to 75VDC or open circuit
- Output ripple and noise measured with 10µF tantalum and 1µF ceramic capacitor across output. (48V: 1µF ceramic cap. only)
- Suffix "-C" to the model number with clear mounting insert. (3.2mm DIA.)
- Require a 47µF aluminum capacitor connected between +Vout and -Vout for 48Vout models.

CHB75 Dual SERIES

75 WATT, DUAL OUTPUTS

Features

- ◆ 75W Isolated Output
- ◆ Efficiency to 84%
- ◆ 400KHz Switching Frequency
- ◆ 2 : 1 Input Range
- ◆ Regulated Outputs
- ◆ Continuous Short Circuit Protection
- ◆ Half-Brick Size Meet Industrial Standard
- ◆ Total Power 75W with 15A Maximum Per Channel
- ◆ UL60950-1 Approval



Mechanical Dimensions

All Dimensions in Inches (mm)
 Tolerance Inches: X.XX±0.02, X.XXX±0.010
 Millimeters: X.X±0.5, X.XX±0.25

Mounting Inserts
 M3*0.5 Through 4pl.

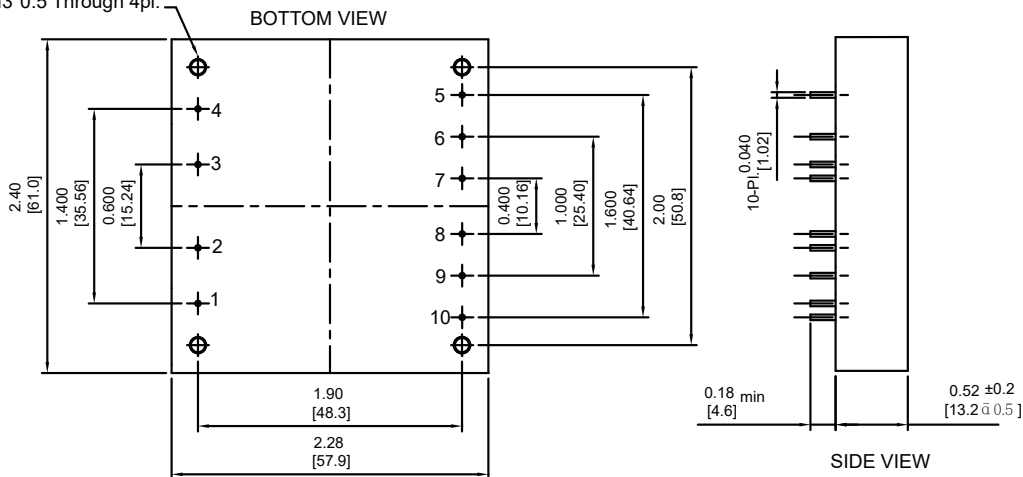

PIN CONNECTION	
PIN	Function
1	+V Input
2	On/Off
3	Case
4	-V Input
5	-Vo2
6	-Vo2
7	-Vo2 Trim
8	+Vo1
9	-Vo1
10	Vo1 Trim

MODEL NUMBER	INPUT VOLTAGE	OUTPUT VOLTAGE	OUTPUT CURRENT		INPUT CURRENT		% EFF.	CAPACITOR LOAD MAX.
			MIN.	MAX.	NO LOAD	FULL LOAD		
CHB75-24D05-3V3	18-36 VDC	VO1= 5 V VO2= 3.3 V	0 A	15 A	50 mA	3765 mA	83% ⁽²⁾	15000µF
CHB75-24D05-2V5	18-36 VDC	VO1= 5 V VO2= 2.5 V	0 A	15 A	50 mA	3765 mA	83% ⁽²⁾	15000µF
CHB75-48D05-3V3	36-75 VDC	VO1= 5 V VO2= 3.3 V	0 A	15 A	30 mA	1860 mA	84% ⁽²⁾	15000µF
CHB75-48D05-2V5	36-75 VDC	VO1= 5 V VO2= 2.5 V	0 A	15 A	30 mA	1860 mA	84% ⁽²⁾	15000µF

NOTE:

1. Nominal Input Voltage 24, 48VDC
2. Measured with 15A Load on Vo1

Remote On/Off Control

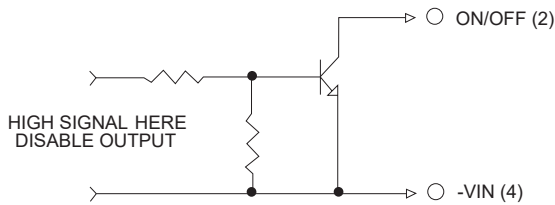

External Output Trim

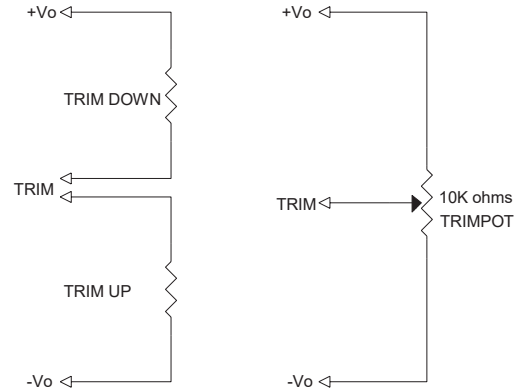

Specifications

All Specifications Typical At Nominal Line, Full Load, and 25°C Unless Otherwise Noted

INPUT SPECIFICATIONS

Input Voltage Range	24V 18-36V	48V 36-75V
Input Surge Voltage (100ms max.)	24V 50Vdc max.	48V 100Vdc max.
Under Voltage Lockout	24Vin	power up 17V
	48Vin	power down 15.5V
		power up 34V
		power down 32.5V
Positive Logic Remote On/Off	See note 4 & 5	
Input Filter	Pi Type	

OUTPUT SPECIFICATIONS

Voltage Accuracy	±2% max.
Transient Response: 25% Step Load Change	< 500µs
External Trim Adj. Range, Each Output	±5%
Ripple & Noise, 20MHz BW (note 6)	40mV RMS max.
	100mV pk-pk max.
Temperature Coefficient	±0.03%/°C
Short Circuit Protection	Continuous
Line Regulation (note 1)	±0.2% max.
Load Regulation (note 2)	±0.5% max.
Over Voltage Protection Trip Range, % Vo nom.	115-140%
Current Limit (note 3)	110%-140% Nominal Output
Start up time	20ms typ.

GENERAL SPECIFICATIONS

Efficiency	See Table
Isolation Voltage	Input/Output 1500VDC min.
	Input/Case 1500VDC min.
	Output/Case 1500VDC min.
	10 ⁷ ohm min.
Isolation Resistance	1000pF typ.
Isolation Capacitance	400KHz typ.
Switching Frequency	-40°C to 100°C
Operating Case Temperature	-55°C to +105°C
Storage Temperature	95% RH max. Non condensing
Humidity	700 Khrs typ.
MTBF MIL-HDBK-217F, GB, 25°C, Full Load	100°C typ.
Thermal Shutdown Range Case Temp.	2.28 x 2.40 x 0.52 inches
Dimensions	(57.9 x 61.0 x 13.2 mm)
	Aluminum Baseplate with
Case Material	Plastic Case
	108 g
Weight	

NOTE

1. Measured from high line to low line.
2. Measured from full load to min. load.
3. Measured with output current on output1 (Vo1)
4. Logic compatibility open collector refer to -Input
Module On open circuit
Module Off < 0.8VDC
5. Suffix "N" to the model number with negative logic remote On/Off.
6. The output noise is measured with 10µF tantalum and 1µF ceramic capacitor across output.
7. Suffix "-C" to the model number with clear mounting insert (3.2mm DIA.)

CHB100 SERIES

66-100 WATT

Features

- ◆ 66W-100W Isolated Output
- ◆ Efficiency to 89%
- ◆ 500KHz Switching Frequency
- ◆ 2 : 1 Input Range
- ◆ Regulated Outputs
- ◆ Continuous Short Circuit Protection
- ◆ Five-Sided Metal Case
- ◆ Half-Brick Size Meet Industrial Standard
- ◆ UL60950-1 Approval
- ◆ Without Tantalum Capacitor Inside (V2.X Only, with  Label)



Mechanical Dimensions

All Dimensions in Inches (mm)
 Tolerance Inches: X.XX=±0.02, X.XXX=±0.010
 Millimeters: X.X=±0.5, X.XX=±0.25

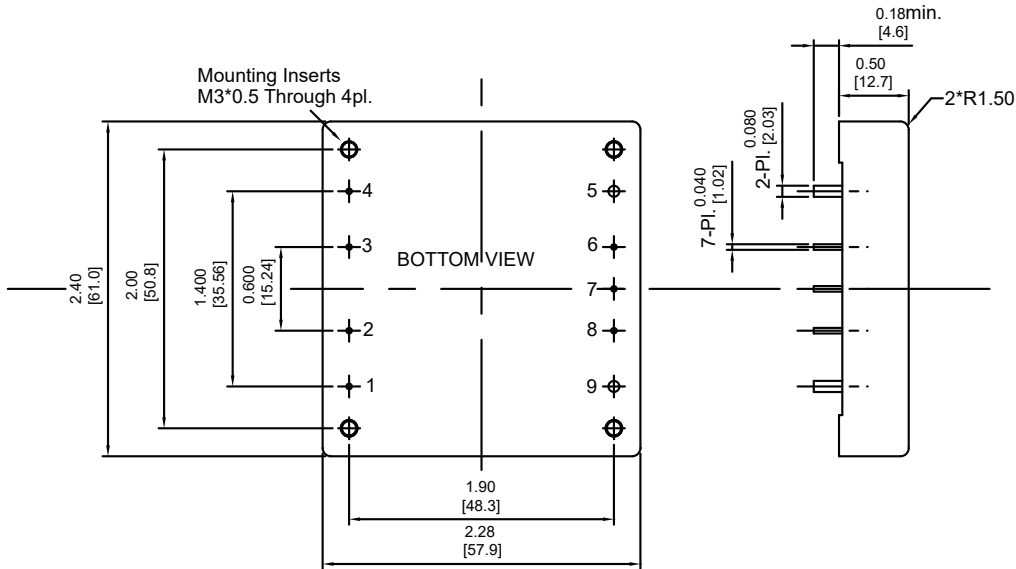

PIN CONNECTION	
PIN	Function
1	+V Input
2	On/Off
3	Case
4	-V Input
5	-V Output
6	-Sense
7	Trim
8	+Sense
9	+V Output

MODEL NUMBER	INPUT VOLTAGE	OUTPUT VOLTAGE	OUTPUT CURRENT		INPUT CURRENT		% EFF.	CAPACITOR LOAD MAX.
			MIN.	MAX.	NO LOAD	FULL LOAD		
CHB100-24S33	18-36 VDC	3.3 VDC	0 mA	20 A	50 mA	3313 mA	83	20000µF
CHB100-24S05	18-36 VDC	5 VDC	0 mA	20 A	50 mA	4960 mA	84	20000µF
CHB100-24S12	18-36 VDC	12 VDC	0 mA	8.3 A	50 mA	4770 mA	87	8300µF
CHB100-24S15	18-36 VDC	15 VDC	0 mA	6.7 A	50 mA	4758 mA	88	6700µF
CHB100-24S24	18-36 VDC	24 VDC	0 mA	4.17 A	50 mA	4793 mA	87	4170µF
CHB100-48S33	36-75 VDC	3.3 VDC	0 mA	20 A	50 mA	1676 mA	82	20000µF
CHB100-48S05	36-75 VDC	5 VDC	0 mA	20 A	50 mA	2422 mA	86	20000µF
CHB100-48S12	36-75 VDC	12 VDC	0 mA	8.3 A	50 mA	2331 mA	89	8300µF
CHB100-48S15	36-75 VDC	15 VDC	0 mA	6.7 A	50 mA	2352 mA	89	6700µF
CHB100-48S24	36-75 VDC	24 VDC	0 mA	4.17 A	50 mA	2369 mA	88	4170µF

NOTE: 1. Nominal Input Voltage 24 or 48VDC

Remote On/Off Control

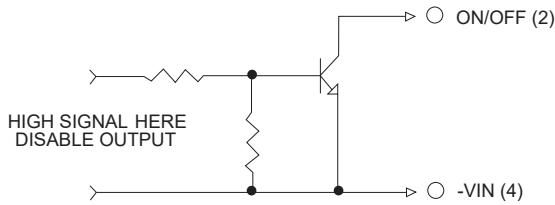

External Output Trim

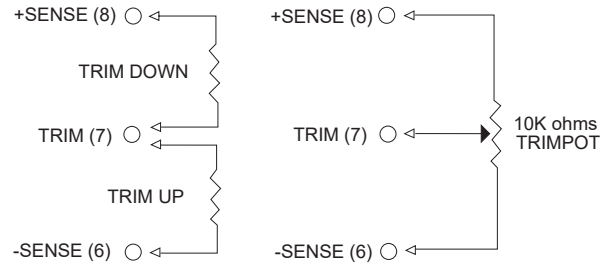

Specifications

All Specifications Typical At Nominal Line, Full Load, and 25°C Unless Otherwise Noted

INPUT SPECIFICATIONS

Input Voltage Range	24V.....18-36V	48V.....36-75V
Input Surge Voltage (100ms max.)	24V 50Vdc max.	48V 100Vdc max.
Under Voltage Lockout:		
24Vin	power up >17V	power down >16V
48Vin	power up >34V	power down >32.5V
Positive Logic Remote On/Off	See note 3 & 4	
Input Filter	Pi Type	

OUTPUT SPECIFICATIONS

Voltage Accuracy	±1.0% max.
Transient Response:25% Step Load Change	< 500µs
External Trim Adj. Range	±10%
Ripple & Noise, 20MHz BW (note 5)	
3.3V & 5V	40mV RMS max. 100mV pk-pk max.
12V & 15V	60mV RMS max. 150mV pk-pk max.
24V	100mV RMS max. 240mV pk-pk max.
Temperature Coefficient	±0.03%/°C
Short Circuit Protection	Continuous
Line Regulation (note 1)	±0.2% max.
Load Regulation (note 2)	±0.2% max.
Over Voltage Protection Trip Range ,% Vo nom.	115-140%
Current Limit	110%-140% Nominal Output
Start up time	5ms typ.

GENERAL SPECIFICATIONS

Efficiency	See Table
Isolation Voltage	Input/Output 1500VDC min. Input/Case 1500VDC min. Output/Case 1500VDC min.
Isolation Resistance	10 ⁷ ohm min.
Isolation Capacitance	1000pF typ.
Switching Frequency	500KHz typ.
Operating Case Temperature	-40°C to +100°C
Storage Temperature	-40°C to +105°C
Thermal Shutdown Case Temp.	100°C typ.
Humidity	95% RH max. Non condensing
MTBF MIL-STD-217F, GB, 25°C, Full Load	900Khrs typ.
Dimensions	2.28 × 2.40 × 0.50 inches (57.9 × 61.0 × 12.7 mm)
Case Material	Aluminum
Weight	95 g

NOTE

1. Measured from high line to low line.
2. Measured from full load to zero load.
3. Logic compatibility open collector ref to -Input
 Module On open circuit
 Module Off < 0.8VDC
4. Suffix "N" to the model number with negative logic remote On/Off.
5. Output ripple and noise measured with 10µF tantalum and 1µF ceramic capacitor across output.
6. Suffix "-C" to the model number with clear mounting insert. (3.2mm DIA.)

CHB100-110S SERIES

100 WATT, INPUT RANGE 66-160 VDC

Features

- ◆ 100W Isolated Output
- ◆ Efficiency to 89%
- ◆ Low No Load Input Power
- ◆ 3:1 Input Range
- ◆ Regulated Outputs
- ◆ Remote On/Off
- ◆ Over Temperature Protection
- ◆ Over Voltage/Current Protection
- ◆ Continuous Short Circuit Protection
- ◆ Half Brick Size meets industrial standard
- ◆ Meets EN50155 With External Circuits
- ◆ Shock & Vibration Meets EN50155 (EN61373)
- ◆ Fire & Smoke meet EN45545-2
- ◆ 3000m Operating Altitude
- ◆ Meets UL60950-1
- ◆ LVD Approval



Mechanical Dimensions

All Dimensions in Inches (mm)
 Tolerance Inches: X.XX=±0.02, X.XXX=±0.010
 Millimeters: X.X=±0.5, X.XX=±0.25

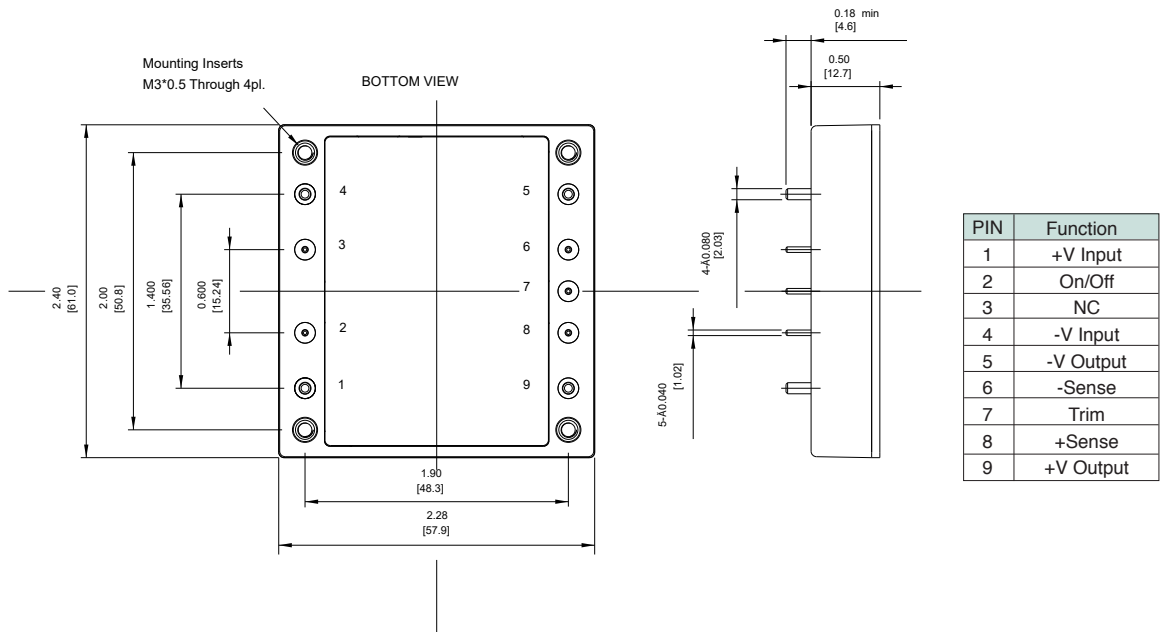

MODEL NUMBER	INPUT VOLTAGE	OUTPUT VOLTAGE	OUTPUT CURRENT		INPUT CURRENT		% EFF.	CAPACITOR LOAD MAX.
			MIN.	MAX.	NO LOAD	FULL LOAD		
CHB100-110S12	66-160 VDC	12 VDC	0 mA	8.3 A	5 mA	1050 mA	86.5	8300µF
CHB100-110S15	66-160 VDC	15 VDC	0 mA	6.7 A	5 mA	1040 mA	87.5	4170µF
CHB100-110S24	66-160 VDC	24 VDC	0 mA	4.17 A	5 mA	1040 mA	87.5	4170µF
CHB100-110S48	66-160 VDC	48 VDC	0 mA	2.08 A	5 mA	1020 mA	89	1500µF

NOTE: 1. Nominal Input Voltage 110VDC

Remote On/Off Control

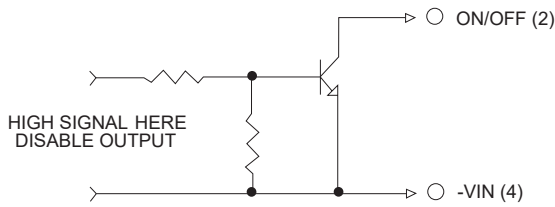

External Output Trim

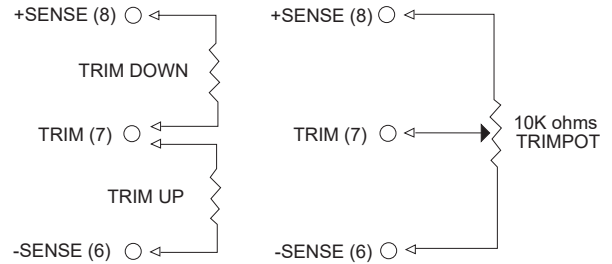

Specifications

All Specifications Typical At Nominal Line, Full Load, and 25°C Unless Otherwise Noted

INPUT SPECIFICATIONS

Input Voltage Range	110V, 66-160V
Input Surge Voltage (100ms max.)	180Vdc max.
Under voltage lockout	power up 62V power down 56V
Positive Logic Remote On/Off:	
Logic Compatibility	Open Collector ref to -Input
Module On	Open Circuit
Module Off	0 to < 1.8Vdc
Input Filter	PI Type

OUTPUT SPECIFICATIONS

Voltage Accuracy	±1.0% max.
Transient Response:	
25% Step Load Change	< 500µs
External Trim Adj. Range	±10%
Ripple & Noise, 20MHz BW(note 3)	
12V, 15V	60mVRMS, 150mVpk-pk max.
24V	100mVRMS, 240mVpk-pk max.
48V	200mVRMS, 480mVpk-pk max.
Temperature Coefficient	±0.03%/°C
Short Circuit Protection	Continuous
Line Regulation (note 1)	±0.2% max.
Load Regulation (note 2)	±0.2% max.
Over Voltage Protection trip Range, % Vo nom.	115-140%
Current Limit	110%-160% Nominal Output
Start up time	120ms typ.

GENERAL SPECIFICATIONS

Efficiency	See Table
Isolation Voltage	Input/Output 3000Vrms min. Input/Case.....1500Vrms min. Output/Case.....500Vrms min. 10 ⁹ ohm min.
Isolation Resistance	500pF typ.
Isolation Capacitance	250KHz typ.
Switching Frequency	-40°C to 100°C
Operating Case Temperature	-55°C to +105°C
Storage Temperature	105°C typ.
Thermal Shutdown, Case Temp.	95% RH max. Non condensing
Humidity	MIL-HDBK-217F, GB, 25°C, Full Load
MTBF	700Khrs typ.
Safety	Meets UL60950-1
EMI(note 6)	EN50155(EN50121-3-2) with external filter
Shock/Vibration	EN50155 (EN61373) EN50155
Environmental	Meets EN50155(EN60068-2-1)
Dimensions	2.28 × 2.40 × 0.50 inches (57.9 × 61.0 × 12.7 mm)
Case Material	Aluminum Baseplate with Plastic Case
Weight	95g

NOTE

1. Measured from high line to low line.
2. Measured from full load to zero load.
3. Output ripple and noise measured with 10µF tantalum and 1µF ceramic capacitor across output. (48V: 1µF ceramic cap. only).
4. An external input capacitor 47µF for all models are recommended to reduce input ripple voltage.
5. Require a 47µF aluminum capacitor connected between +Vout and -Vout for 48Vout models.
6. For information about EN50155 and RIA12, refer to application note.

CHB100W SERIES

66 - 100 WATT, 4:1 INPUT RANGE

Features

- ◆ 66W-100W Isolated Output
- ◆ Efficiency to 89%
- ◆ 250KHz Switching Frequency
- ◆ 4 : 1 Input Range
- ◆ Regulated Outputs
- ◆ Continuous Short Circuit Protection
- ◆ Five-Sided Metal Case
- ◆ Half-Brick Size Meet Industrial Standard
- ◆ UL60950-1 Approval (Except 28 Vout)

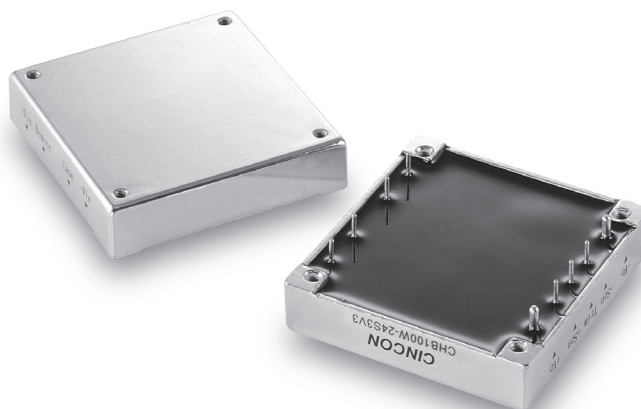

Mechanical Dimensions

All Dimensions in Inches (mm)
 Tolerance Inches: X.XX=±0.02, X.XXX=±0.010
 Millimeters: X.X=±0.5, X.XX=±0.25

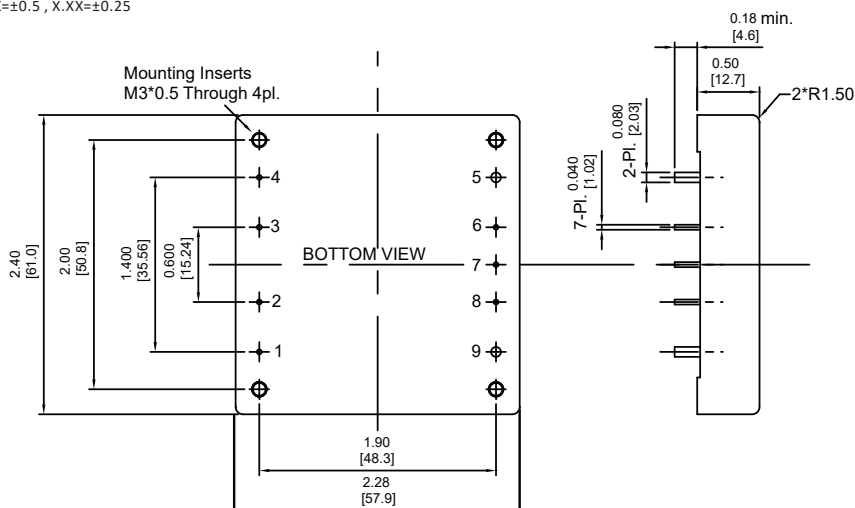

PIN CONNECTION	
PIN	Function
1	+V Input
2	On/Off
3	Case
4	-V Input
5	-V Output
6	-Sense
7	Trim
8	+Sense
9	+V Output

MODEL NUMBER	INPUT VOLTAGE	OUTPUT VOLTAGE	OUTPUT CURRENT		INPUT CURRENT		% EFF.	CAPACITOR LOAD MAX.
			MIN.	MAX.	NO LOAD	FULL LOAD		
CHB100W-24S3V3	9-36 VDC	3.3 VDC	0 mA	20 A	35 mA	3333 mA	82.5	20000µF
CHB100W-24S05	9-36 VDC	5 VDC	0 mA	20 A	35 mA	4931 mA	84.5	20000µF
CHB100W-24S12	9-36 VDC	12 VDC	0 mA	8.3 A	35 mA	4854 mA	85.5	8300µF
CHB100W-24S15	9-36 VDC	15 VDC	0 mA	6.7 A	35 mA	4813 mA	87	6700µF
CHB100W-24S24	9-36 VDC	24 VDC	0 mA	4.17 A	35 mA	4766 mA	87.5	1800µF
CHB100W-24S28	9-36 VDC	28 VDC	0 mA	3.57 A	50 mA	4845 mA	86	2200µF
CHB100W-24S48	9-36 VDC	48 VDC	0 mA	2.08 A	35 mA	5042 mA	82.5	470µF
CHB100W-48S3V3	18-75 VDC	3.3 VDC	0 mA	20 A	30 mA	1667 mA	82.5	20000µF
CHB100W-48S05	18-75 VDC	5 VDC	0 mA	20 A	30 mA	2422 mA	86	20000µF
CHB100W-48S12	18-75 VDC	12 VDC	0 mA	8.3 A	30 mA	2371 mA	87.5	8300µF
CHB100W-48S15	18-75 VDC	15 VDC	0 mA	6.7 A	30 mA	2379 mA	88	6700µF
CHB100W-48S24	18-75 VDC	24 VDC	0 mA	4.17 A	30 mA	2343 mA	89	2200µF
CHB100W-48S28	18-75 VDC	28 VDC	0 mA	3.57 A	50 mA	2422 mA	86	2200µF
CHB100W-48S48	18-75 VDC	48 VDC	0 mA	2.08 A	30 mA	2462 mA	84.5	470µF

Remote On/Off Control

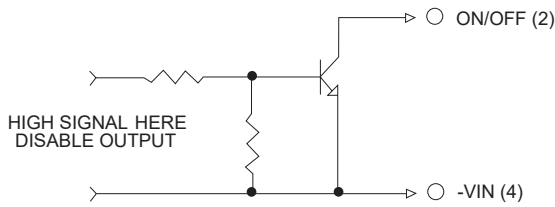

External Output Trim

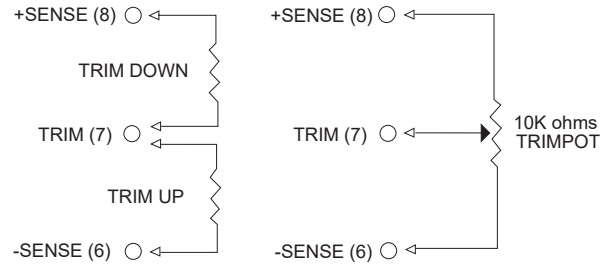

Specifications

All Specifications Typical At Nominal Line, Full Load, and 25°C Unless Otherwise Noted

INPUT SPECIFICATIONS

Input Voltage Range	24V 9-36V
	48V 18-75V
Input Surge Voltage (100ms max.)	24V 50Vdc max.
	48V 100Vdc max.
Under Voltage Lockout	24Vin
	power up 8.8V
	power down 8.0V
	48Vin
	power up 17V
	power down 16V
Positive Logic Remote On/Off	See note 4 & 5
Input Filter	Pi Type

OUTPUT SPECIFICATIONS

Voltage Accuracy	1.0% max.
	3.3V & 48V (note 7)
Transient Response: 25% Step Load Change	< 500µs
External Trim Adj. Range	±10%
Ripple & Noise, 20MHz BW (note3)	
	3.3V & 5V
	40mV RMS max.,
	100mV pk-pk max.
	12V & 15V
	60mV RMS max.,
	150mV pk-pk max.
	24V
	100mV RMS max.,
	240mV pk-pk max.
	28V
	100mV RMS max.,
	280mV pk-pk max.
	48V
	200mV RMS max.,
	480mV pk-pk max.
Temperature Coefficient	±0.03%/°C
Short Circuit Protection	Continuous
Line Regulation (note 1)	±0.2% max.
Load Regulation (note 2)	±0.2% max.
Over Voltage Protection Trip Range, % Vo nom.	115-140%
Current Limit	110% -140% Nominal Output
Start up time	25ms typ.

GENERAL SPECIFICATIONS

Efficiency	See Table
Isolation Voltage	Input/Output, Input/Case, Output/Case 1500VDC min.
Isolation Resistance	10 ⁷ ohm min.
Isolation Capacitance	1500pF typ.
Switching Frequency	250KHz typ.
Operating Case Temperature	-40°C to 100°C
Storage Temperature	-55°C to +105°C
Thermal Shutdown Case Temp.	105°C typ.
Humidity	95% RH max. Non condensing
MTBFMIL-HDBK-217F, GB, 25°C, Full Load	700Khrs typ.
Dimensions	2.28 x 2.40 x 0.50 inches (57.9 x 61.0 x 12.7 mm)
Case Material	Aluminum
Weight	95 g

NOTE

1. Measured from high line to low line.
2. Measured from full load to zero load.
3. Output ripple and noise measured with 10µF tantalum and 1µF ceramic capacitor across output. (48V: 0.1µF ceramic cap. only)
4. Logic Compatibility open collector ref to -input

Module On	>3.5VDC or open circuit
Module Off	0 to <1.8VDC
5. Suffix "N" to the model number with negative logic remote On/Off

Module On	0 to <1.8VDC
Module Off	>3.5VDC or open circuit
6. Suffix "-C" to the model number with clear mounting insert. (3.2mm DIA.)
7. Require a 47µF aluminum capacitor connected between +Vout and -Vout for 48Vout models.

CHE100/CHE100W SERIES

100 WATT, 4:1 INPUT RANGE

Features

- ◆ 100W Isolated Output
- ◆ Half-Brick Size, Six-Sided Shield Metal Case
- ◆ High Efficiency to 93%
- ◆ 4 : 1 Input Range
- ◆ Regulated Outputs
- ◆ 250KHz Switching Frequency
- ◆ Continuous Short Circuit Protection
- ◆ Input Under-Voltage Protection
- ◆ Over Temperature/Voltage/Current Protection
- ◆ Remote On/Off
- ◆ Full Load Operation up to 60°C with Heat-Sink M-C091 Natural Convention
- ◆ No Tantalum Capacitor Inside
- ◆ Safety Meets UL60950-1, EN60950-1, and IEC60950-1



Mechanical Dimensions

All Dimensions in Inches (mm)
 Tolerance Inches: X.XX=±0.02, X.XXX=±0.010
 Millimeters: X.X=±0.5, X.XX=±0.25

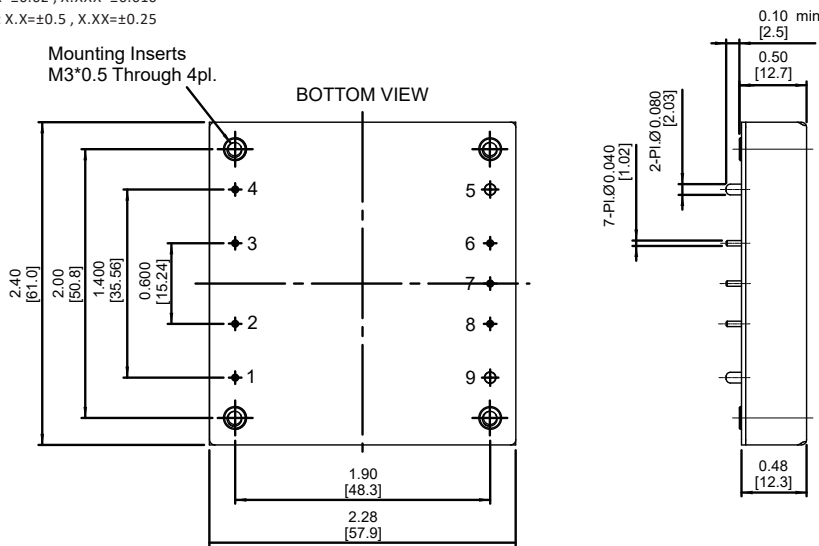

PIN CONNECTION	
PIN	Function
1	+V Input
2	On/Off
3	Case
4	-V Input
5	-V Output
6	-Sense
7	Trim
8	+Sense
9	+V Output

CHE100W Series

MODEL NUMBER	INPUT VOLTAGE	OUTPUT VOLTAGE	OUTPUT CURRENT		INPUT CURRENT		% EFF.		CAPACITOR LOAD MAX.
			MIN.	MAX.	NO LOAD	FULL LOAD	(4)	(3)	
CHE100W-24S3V3	9-36 VDC	3.3 VDC	0 mA	25 A	200 mA	3.94 A	85.5	87	25000µF
CHE100W-24S05	9-36 VDC	5 VDC	0 mA	20 A	150 mA	4.66 A	88.5	89.5	20000µF
CHE100W-24S12	9-36 VDC	12 VDC	0 mA	8.4 A	200 mA	4.62 A	90	90.5	8400µF
CHE100W-24S15	9-36 VDC	15 VDC	0 mA	6.7 A	200 mA	4.62 A	89.5	90.5	6700µF
CHE100W-24S24	9-36 VDC	24 VDC	0 mA	4.2 A	100 mA	4.76 A	88.5	89	4200µF ⁽²⁾
CHE100W-24S48	9-36 VDC	48 VDC	0 mA	2.1 A	100 mA	4.76 A	89.5	88.5	2100µF ⁽²⁾
CHE100W-48S3V3	18-75 VDC	3.3 VDC	0 mA	25 A	130 mA	1.96 A	87.5	88	25000µF
CHE100W-48S05	18-75 VDC	5 VDC	0 mA	20 A	130 mA	2.28 A	91.5	92	20000µF
CHE100W-48S12	18-75 VDC	12 VDC	0 mA	8.4 A	100 mA	2.26 A	92.5	93	8400µF
CHE100W-48S15	18-75 VDC	15 VDC	0 mA	6.7 A	100 mA	2.26 A	91.5	92.5	6700µF
CHE100W-48S24	18-75 VDC	24 VDC	0 mA	4.2 A	100 mA	2.32 A	91	91	4200µF ⁽²⁾
CHE100W-48S48	18-75 VDC	48 VDC	0 mA	2.1 A	100 mA	2.32 A	91.5	90.5	2100µF ⁽²⁾

NOTE:

1. Nominal Input Voltage 24, 48 VDC
2. Require a 10µF Aluminum Capacitor Connected Between +Vout and -Vout for 24 & 48Vout Models.
3. Measured at Nominal Input Voltage.
4. Measured at 12VDC for 24SXX, 24VDC for 48SXX.

Remote On/Off Control

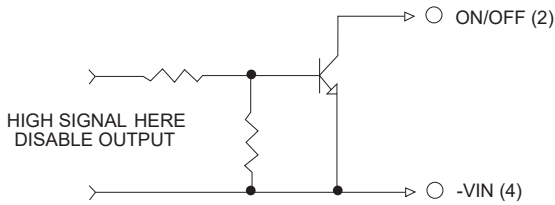

External Output Trim

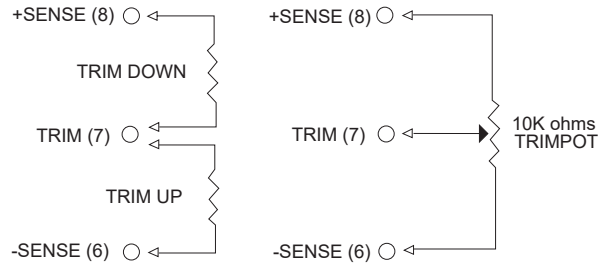

Derating Curve

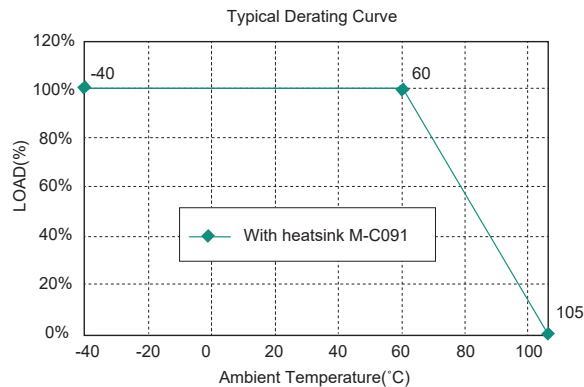

Specifications

All Specifications Typical At Nominal Line, Fill Load, and 25°C Unless Otherwise Noted

INPUT SPECIFICATIONS

Input Voltage Range .	24V 9-36V
	48V 18-75V
Input Surge Voltage (100ms max.)	24V 50Vdc max.
	48V 100Vdc max.
Under voltage lockout 24Vin	power up 8.8V
	power down 8.0V
48Vin	power up 17V
	power down 16V
Positive Logic Remote On/Off	see note 4 & 5
Input Filter	PI Type

OUTPUT SPECIFICATIONS

Voltage Accuracy	±1.0% max.
Transient Response: 25% Step Load Change	< 500µs
External Trim Adj. Range	±10%
Ripple & Noise, 20MHz BW	
3.3V & 5V	40mV RMS, 100mV pk-pk max.
12V & 15V	60mV RMS, 120mV pk-pk max.
24V	100mV RMS, 240mV pk-pk max.
48V	200mV RMS, 480mV pk-pk max.
Temperature Coefficient	±0.03%/°C
Short Circuit Protection	Continuous
Line Regulation(note 1)	±0.2% max.
Load Regulation(note 2)	±0.2% max.
Over Voltage Protection trip Range, % Vo nom.	115-140%
Current Limit	110% -140% Nominal Output
Start up time	10ms typ.

GENERAL SPECIFICATIONS

Efficiency	See Table
Isolation Voltage	Input/Output 1500VDC min.
	Input/Case 1500VDC min.
	Output/Case 1500VDC min.
	10 ⁷ ohm min.
Isolation Resistance	1000pF typ.
Isolation Capacitance	250KHz typ.
Switching Frequency	-40°C to 105°C.
Operating Case Temperature	-55°C to +105°C
Storage Temperature	110°C typ.
Thermal Shutdown, Case Temperature	95% RH max. Non condensing
Humidity	XXS05: 750Khrs typ.
MTBF MIL-STD-217F, GB, 25°C, Full Load	Others: 880Khrs typ.
Dimensions	2.28 x 2.40 x 0.50 inches
	(57.9 x 61.0 x 12.7 mm)
Case Material	Aluminum with Non-Conducted Base
Weight	95 g

NOTE

- Measured from high line to low line.
- Measured from full load to zero load.
- Output ripple and noise measured with 10µF tantalum and 1µF ceramic capacitor across output.
(24V & 48V: 10µF aluminum and 1µF ceramic capacitor across output.)
- Logic compatibility open collector refer to -Vin
Module On >3.5VDC to 75VDC or open circuit
Module Off 0 to < 1.2VDC
- Suffix "N" to the model number with negative logic remote on/off
Module On 0 to < 1.2VDC
Module Off >3.5VDC to 75VDC or open circuit

CHB150 SERIES

99-150 WATT

Features

- ◆ 99W-150W Isolated Output
- ◆ Efficiency to 89%
- ◆ 500KHz Switching Frequency
- ◆ 2 : 1 Input Range
- ◆ Regulated Outputs
- ◆ Continuous Short Circuit Protection
- ◆ Five-Sided Metal Case
- ◆ Half-Brick Size Meet Industrial Standard
- ◆ CE Mark Meets 2004/108/EC
- ◆ UL60950-1 Approval
- ◆ Without Tantalum Capacitor Inside
(V2.X Only, with  Label)

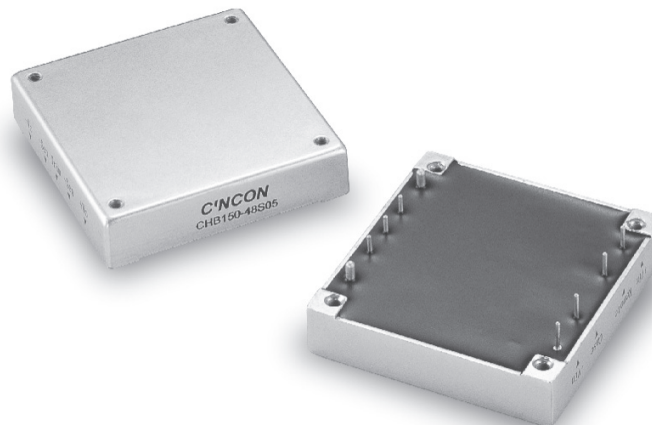

Mechanical Dimensions

All Dimensions in Inches (mm)
 Tolerance Inches: X.XX±0.02, X.XXX±0.010
 Millimeters: X.X±0.5, X.XX±0.25

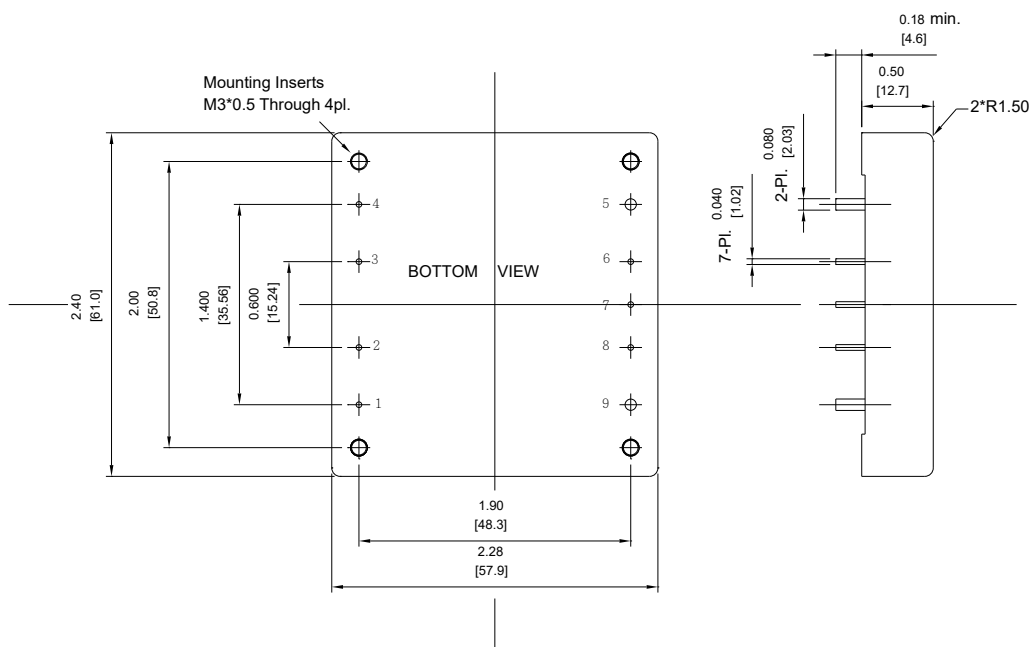

PIN CONNECTION	
PIN	Function
1	+V Input
2	On/Off
3	Case
4	-V Input
5	-V Output
6	-Sense
7	Trim
8	+Sense
9	+V Output

MODEL NUMBER	INPUT VOLTAGE	OUTPUT VOLTAGE	OUTPUT CURRENT		INPUT CURRENT		% EFF.	CAPACITOR LOAD MAX.
			MIN.	MAX.	NO LOAD	FULL LOAD		
CHB150-48S33	36-75 VDC	3.3 VDC	0 mA	30 A	25 mA	2.5 A	82	30000µF
CHB150-48S05	36-75 VDC	5 VDC	0 mA	30 A	25 mA	3.6 A	86	30000µF
CHB150-48S12	36-75 VDC	12 VDC	0 mA	12.5 A	25 mA	3.5 A	89	12500µF
CHB150-48S15	36-75 VDC	15 VDC	0 mA	10 A	25 mA	3.5 A	89	10000µF
CHB150-48S24	36-75 VDC	24 VDC	0 mA	6.25 A	25 mA	3.5 A	89	6250µF

NOTE: 1. Nominal Input Voltage 48VDC

Remote On/Off Control

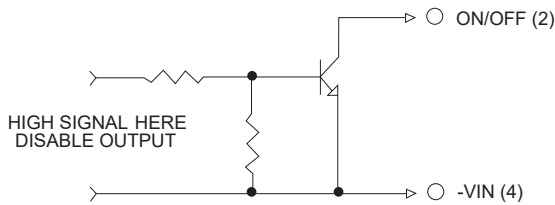

External Output Trim

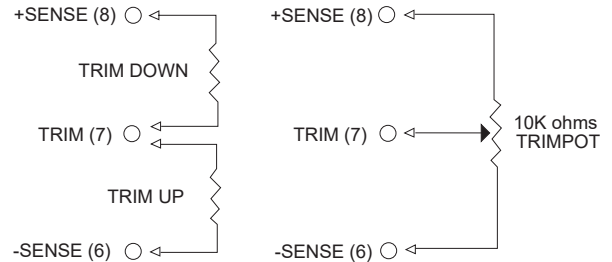

Specifications

All Specifications Typical At Nominal Line, Full Load, and 25°C Unless Otherwise Noted

INPUT SPECIFICATIONS

Input Voltage Range	48V.....	36-75V
Input Surge Voltage (100ms max.)	48V	100Vdc max.
Under Voltage Lockout	48Vin	power up 34V
	48Vin	power down.....32.5V
Positive Logic Remote On/Off		See note 3 & 4
Input Filter		Pi Type

OUTPUT SPECIFICATIONS

Voltage Accuracy	±1.0% max.
Transient Response: 25% Step Load Change	< 500µs
External Trim Adj. Range	±10%
Ripple & Noise, 20MHz BW (note 5)	
3.3V & 5V	40mV RMS max. 100mV pk-pk max.
12V & 15V	60mV RMS max. 150mV pk-pk max.
24V	100mV RMS max. 240mV pk-pk max.
Temperature Coefficient	±0.03%/°C
Short Circuit Protection	Continuous
Line Regulation (note 1)	±0.2% max.
Load Regulation (note 2)	±0.2% max.
Over Voltage Protection Trip Range, % Vo nom.	115-140%
Current Limit	110%-140% Nominal Output
Start up time	5ms typ.

GENERAL SPECIFICATIONS

Efficiency	See Table
Isolation Voltage	Input/Output 1500VDC min. Input/Case 1500VDC min. Output/Case 1500VDC min. 10 ⁷ ohm min.
Isolation Resistance	1000pF typ.
Isolation Capacitance	500KHz typ.
Switching Frequency	-40°C to 100°C
Operating Case Temperature	-40°C to +105°C
Storage Temperature	95% RH max. Non condensing
Humidity	900Khrs typ.
MTBF MIL-STD-217F, GB, 25°C, Full Load	100°C typ.
Thermal Shutdown Case Temp.	2.28 x 2.40 x 0.50 inches (57.9 x 61.0 x 12.7 mm)
Dimensions	Aluminum
Case Material	100 g
Weight	

NOTE

1. Measured from high line to low line.
2. Measured from full load to zero load.
3. Logic compatibility open collector ref to -Input
 Module On open circuit
 Module Off < 0.8VDC
4. Suffix "N" to the model number with negative logic remote On/Off.
5. Output ripple and noise measured with 10µF tantalum and 1µF ceramic capacitor across output.
6. Suffix "-C" to the model number with clear mounting insert. (3.2mm DIA.)

CHB150W SERIES

99-150 WATT, 4:1 INPUT RANGE

Features

- ◆ 99W-150W Isolated Output
- ◆ Efficiency to 91%
- ◆ 250KHz Switching Frequency
- ◆ 4 : 1 Input Range
- ◆ Regulated Outputs
- ◆ Remote On/Off
- ◆ Over Temperature Protection
- ◆ Over Voltage/Current Protection
- ◆ Continuous Short Circuit Protection
- ◆ Half-Brick Size Meet Industrial Standard
- ◆ CE Mark Meets 2004/108/EC
- ◆ UL60950-1 Approval (Except 28&48 Vout)



Mechanical Dimensions

All Dimensions in Inches (mm)
 Tolerance Inches: X.XX=±0.02, X.XXX=±0.010
 Millimeters: X.X=±0.5, X.XX=±0.25

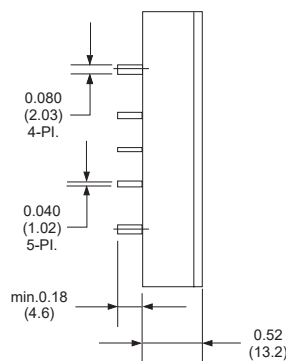
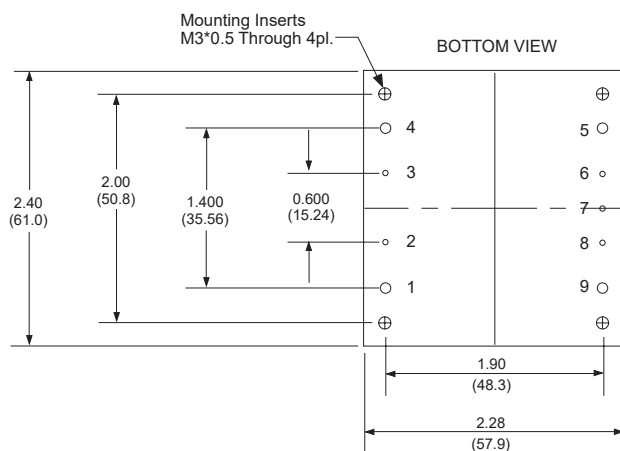

PIN CONNECTION	
PIN	Function
1	+V Input
2	On/Off
3	Case
4	-V Input
5	-V Output
6	-Sense
7	Trim
8	+Sense
9	+V Output

MODEL NUMBER	INPUT VOLTAGE	OUTPUT VOLTAGE	OUTPUT CURRENT		INPUT CURRENT		% EFF.	CAPACITOR LOAD MAX.
			MIN.	MAX.	NO LOAD	FULL LOAD		
CHB150W-24S3V3	9-36 VDC	3.3 VDC	0 mA	30 A	200 mA	4741 mA	87	30000µF
CHB150W-24S05	9-36 VDC	5 VDC	0 mA	30 A	200 mA	7184 mA	87	30000µF
CHB150W-24S12	9-36 VDC	12 VDC	0 mA	12.5 A	100 mA	7102 mA	88	12500µF
CHB150W-24S15	9-36 VDC	15 VDC	0 mA	10 A	100 mA	7184 mA	87	10000µF
CHB150W-24S24	9-36 VDC	24 VDC	0 mA	6.5 A	100 mA	7386 mA	88	1800µF
CHB150W-24S28	9-36 VDC	28 VDC	0 mA	5.4 A	100 mA	7325 mA	86	1800µF
CHB150W-24S48	9-36 VDC	48 VDC	0 mA	3.12 A	200 mA	7428 mA	84	1000µF
CHB150W-48S3V3	18-75 VDC	3.3 VDC	0 mA	30 A	100 mA	2344 mA	88	30000µF
CHB150W-48S05	18-75 VDC	5 VDC	0 mA	30 A	100 mA	3472 mA	90	30000µF
CHB150W-48S12	18-75 VDC	12 VDC	0 mA	12.5 A	50 mA	3434 mA	91	12500µF
CHB150W-48S15	18-75 VDC	15 VDC	0 mA	10 A	50 mA	3472 mA	90	10000µF
CHB150W-48S24	18-75 VDC	24 VDC	0 mA	6.5 A	50 mA	3611 mA	90	2200µF
CHB150W-48S28	18-75 VDC	28 VDC	0 mA	5.4 A	50 mA	3580 mA	88	2200µF
CHB150W-48S48	18-75 VDC	48 VDC	0 mA	3.12 A	100 mA	3633 mA	86	1000µF

Remote On/Off Control

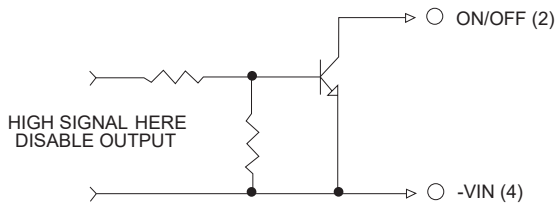

External Output Trim

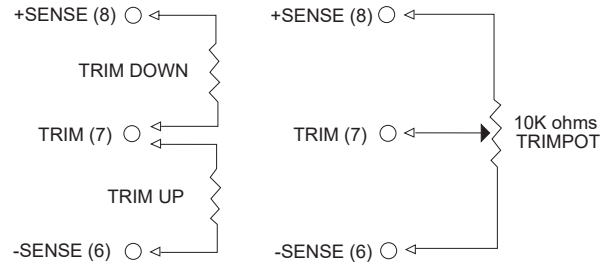

Specifications

All Specifications Typical At Nominal Line, Full Load, and 25°C Unless Otherwise Noted

INPUT SPECIFICATIONS

Input Voltage Range	24V 9-36V
	48V 18-75V
Input Surge Voltage (100ms max.)	24V 50Vdc max.
	48V 100Vdc max.
Under Voltage Lockout	24Vin
	power up 8.8V
	power down 8.0V
	48Vin
	power up 17V
	power down 16V
Positive Logic Remote On/Off	See note 4 & 5
Input Filter	Pi Type

OUTPUT SPECIFICATIONS

Voltage Accuracy	±1.0% max.
3.3V & 48V (note 7)	±1.5% max.
Transient Response: 25% Step Load	< 500µs
Change External Trim Adj. Range	±10%
Ripple & Noise, 20MHz BW (note 3)	
3.3V & 5V	40mV RMS max., 100mV pk-pk max.
12V & 15V	60mV RMS max., 150mV pk-pk max.
24V	100mV RMS max., 240mV pk-pk max.
28V	100mV RMS max., 280mV pk-pk max.
48V	200mV RMS max., 480mV pk-pk max.
Temperature Coefficient	±0.03%/°C
Short Circuit Protection	Continuous
Line Regulation (note 1)	±0.2% max.
Load Regulation (note 2)	±0.2% max.
Over Voltage Protection Trip Range, % Vo nom.	115-140%
Current Limit	110%-140% Nominal Output
Start up time	25ms typ.

GENERAL SPECIFICATIONS

Efficiency	See Table
Isolation Voltage	Input/Output, Input/Case, Output/Case 1500VDC min.
Isolation Resistance	10 ⁷ ohm min.
Isolation Capacitance	1000pF typ.
Switching Frequency	250KHz typ.
Operating Case Temperature	-40°C to 100°C
Storage Temperature	-55°C to +105°C
Thermal Shutdown Case Temp.	110°C typ.
Humidity	95% RH max. Non condensing
MTBF ... MIL-HDBK-217F, GB, 25°C, Full Load	400Khrs typ.
Dimensions	2.28 x 2.40 x 0.52 inches (57.9 x 61.0 x 13.2 mm)
Case Material	Aluminum Baseplate with Plastic Case
Weight	112 g

NOTE

- Measured from high line to low line.
- Measured from full load to zero load.
- Output ripple and noise measured with 10µF tantalum and 1µF ceramic capacitor across output.
- Logic compatibility open collector ref to -input
Module On > 3.5VDC or open circuit
Module Off 0 to <1.8VDC
- Suffix "N" to the model number with negative logic remote On/Off
Module On 0 to <1.8VDC
Module Off > 3.5VDC or open circuit
- Suffix "-C" to the model number with clear mounting insert. (3.2mm DIA.)
- Require a 47µF aluminum capacitor connected between +vout and -vout for 48Vout models.

CHB150-110S SERIES

150 WATT, INPUT RANGE 66-160 VDC

Features

- ◆ 150W Isolated Output
- ◆ Efficiency to 92.5%
- ◆ 200KHz Switching Frequency
- ◆ 3 : 1 Input Range
- ◆ Regulated Outputs
- ◆ Remote On/Off
- ◆ Over Temperature Protection
- ◆ Over Voltage/Current Protection
- ◆ Continuous Short Circuit Protection
- ◆ Half-Brick Size Meets Industrial Standard
- ◆ UL60950-1 Approval
- ◆ Meets EN50155



Mechanical Dimensions

All Dimensions in Inches (mm)
 Tolerance Inches: X.XX=±0.02, X.XXX=±0.010
 Millimeters: X.X=±0.5, X.XX=±0.25

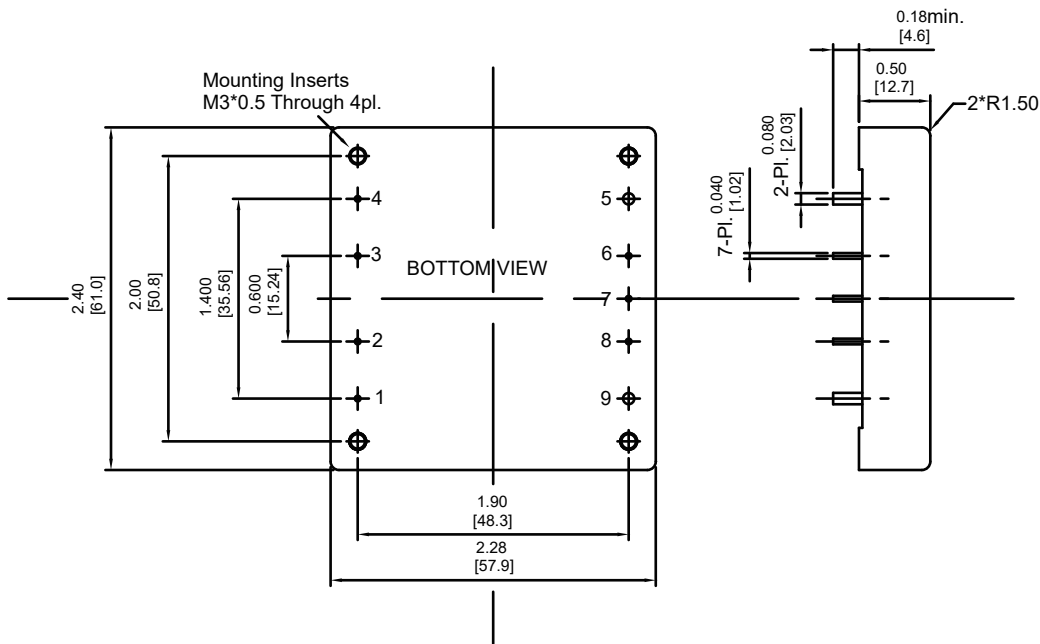

PIN CONNECTION	
PIN	Function
1	+V Input
2	On/Off
3	Case
4	-V Input
5	-V Output
6	-Sense
7	Trim
8	+Sense
9	+V Output

MODEL NUMBER	INPUT VOLTAGE	OUTPUT VOLTAGE	OUTPUT CURRENT		INPUT CURRENT		% EFF.	CAPACITOR LOAD MAX.
			MIN.	MAX.	NO LOAD	FULL LOAD		
CHB150-110S05	66-160 VDC	5 VDC	0 mA	30 A	40 mA	1474 mA	92.5	10000µF
CHB150-110S12	66-160 VDC	12 VDC	0 mA	12.5 A	40 mA	1474 mA	92.5	5600µF
CHB150-110S24	66-160 VDC	24 VDC	0 mA	6.5 A	60 mA	1541 mA	92	2200µF

NOTE: 1. Nominal Input Voltage 110VDC

Remote On/Off Control

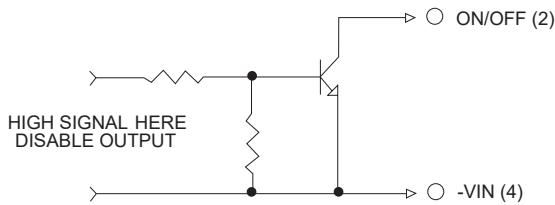

External Output Trim

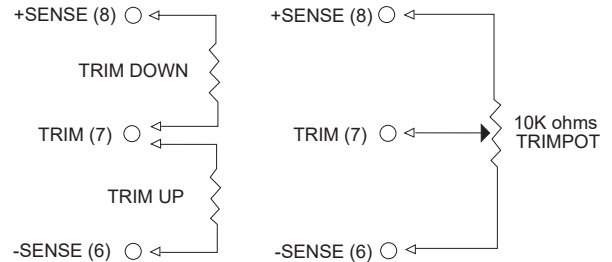

Specifications

All Specifications Typical At Nominal Line, Full Load, and 25°C Unless Otherwise Noted

INPUT SPECIFICATIONS

Input Voltage Range	110V, 66-160V
Input Surge Voltage (100ms max.)	180Vdc max.
Under Voltage Lockout	power up: 62V power down: 56V
Positive Logic Remote On/Off:	
Logic Compatibility	Open Collector ref to -Input
Module On	> 3.5Vdc to 75Vdc or Open Circuit
Module Off	0 to < 1.8Vdc
Input Filter	Pi Type

OUTPUT SPECIFICATIONS

Voltage Accuracy	±1.0% max.
Transient Response:	
25% Step Load Change	Error Band ±5% Vout Recover Time < 200µs
External Trim Adj. Range	±10%
Ripple & Noise, 20MHz BW (note 3)	
5V	40mV RMS, 100mV pk-pk max.
12V	60mV RMS, 150mV pk-pk max.
24V	100mV RMS, 240mV pk-pk max.
Temperature Coefficient	±0.03%/°C
Short Circuit Protection	Continuous
Line Regulation (note 1)	±0.2% max.
Load Regulation (note 2)	±0.2% max.
Over Voltage Protection Trip Range, % Vo nom.	115-140%
Current Limit	110%-180% Nominal Output
Start up time	45ms typ.

GENERAL SPECIFICATIONS

Efficiency	See Table
Isolation Voltage	Input/Output, Input/Case 2250VDC min. Output/Case 1500VDC min. 10 ⁷ ohm min.
Isolation Resistance	1000pF typ.
Isolation Capacitance	200KHz typ.
Switching Frequency	-40°C to 100°C
Operating Case Temperature	-55°C to +105°C
Storage Temperature	105°C typ.
Thermal Shutdown Case Temp.	95% RH max. Non condensing
Humidity	XXS05: 240Khrs typ. Others: 320Khrs typ.
MTBF.....MIL-HDBK-217F, GB, 25°C, Full Load	UL60950-1 2 nd (Basic Insulation) EN50155 (EN50121-3-2) with External Filter EN50155 (EN61373) EN50155 (EN60068-2-1) 2.28 x 2.40 x 0.50 inches (57.9 x 61.0 x 12.7 mm) Aluminum Baseplate with Plastic Case 90 g
Safety	
EMC (note 7)	
Shock/Vibration	
Environmental	
Dimensions	
Case Material	
Weight	

NOTE

1. Measured from high line to low line.
2. Measured from full load to zero load.
3. Output Ripple and Noise measured with 10µF tantalum and 1µF ceramic apacitor across output.
4. Suffix "N" to the model number with negative logic remote On/Off
Module On 0 to < 1.8VDC
Module Off > 3.5VDC to 75VDC or open circuit
5. Suffix "-C" to the model number with clear mounting insert (3.2mm DIA.)
6. An external input capacitor 220µF for all models are recommended to reduce input ripple voltage.
7. Design meet EN50155 and RIA12 refer to application note.

CHB150W8 SERIES

150 WATT, INPUT RANGE 9-75 VDC

Features

- ◆ 150W Isolated Output
- ◆ Efficiency to 90%
- ◆ Fixed Switching Frequency
- ◆ Input Under Voltage Protection
- ◆ Over Temperature Protection
- ◆ Over Voltage/Current Protection
- ◆ Remote On/Off
- ◆ Industry Standard Half-Brick Package
- ◆ Fully Isolated 1500VDC
- ◆ UL60950-1 2nd Approval

PRELIMINARY



Mechanical Dimensions

All Dimensions in Inches (mm)
 Tolerance Inches: X.XX=±0.02, X.XXX=±0.010
 Millimeters: X.X=±0.5, X.XX=±0.25

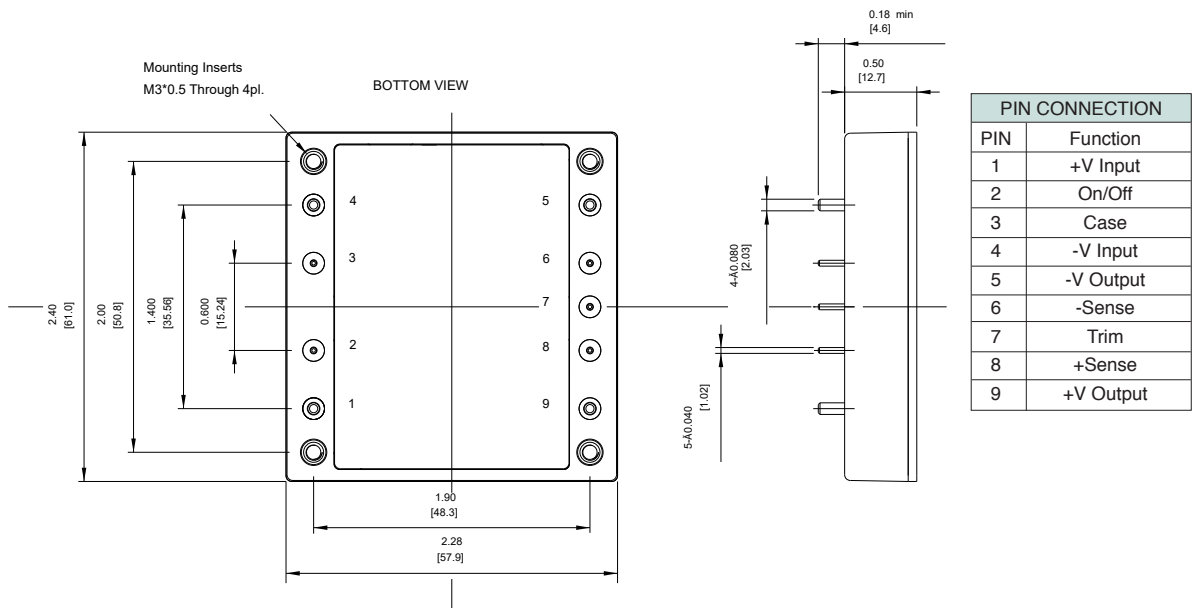

MODEL NUMBER	INPUT VOLTAGE	OUTPUT VOLTAGE	OUTPUT CURRENT		INPUT CURRENT		% EFF.			CAPACITOR LOAD MAX.
			MIN.	MAX.	NO LOAD	FULL LOAD	(2)	(1)	(3)	
CHB150W8-36S12	9-75 VDC	12 VDC	0 mA	12.5 A	60 mA	4.66 A	89.5	89.5	89.5	5000µF
CHB150W8-36S15	9-75 VDC	15 VDC	0 mA	10 A	60 mA	4.63 A	90	90	90	5000µF
CHB150W8-36S24	9-75 VDC	24 VDC	0 mA	6.25 A	60 mA	4.66 A	89.5	89.5	89	2000µF ⁽⁴⁾
CHB150W8-36S28	9-75 VDC	28 VDC	0 mA	5.35 A	60 mA	4.63 A	90	90	89.5	1500µF ⁽⁴⁾
CHB150W8-36S48	9-75 VDC	48 VDC	0 mA	3.13 A	60 mA	4.63 A	90.5	90	89.5	1000µF ⁽⁴⁾

NOTE:
 1. Nominal Input Voltage 36 VDC
 2. Measured at 24Vin
 3. Measured at 48Vin
 4. The output terminal of 24, 28, 48Vout models required a minimum capacitor 100uF to maintain specified regulation.

Remote On/Off Control

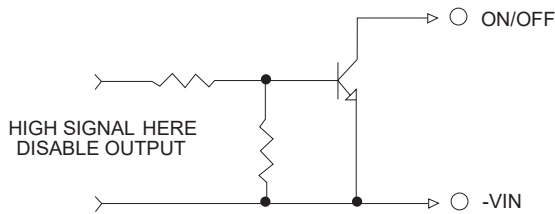

External Output Trim

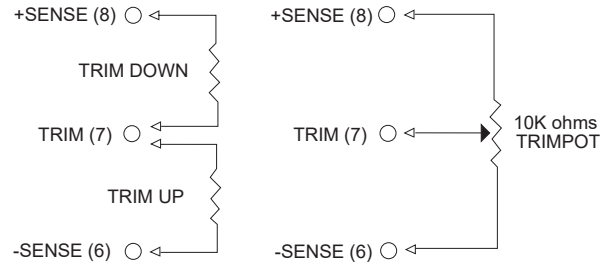

Specifications

All Specifications Typical At Nominal Line, Full Load, and 25°C Unless Otherwise Noted

INPUT SPECIFICATIONS

Operating Input Voltage Range	36V 9-75V
Input Surge Voltage (100ms max.)	100Vdc max
Under Voltage Lockout	power up 9.5V power down 8.0V
Positive Logic Remote On/Off	See note 4 & 5
Input Filter	LC Type

OUTPUT SPECIFICATIONS

Voltage Accuracy	±1.0% max.
Transient Response:25% Step Load Change	< 500µs
External Trim Adj. Range (note 6)	±10%
Ripple & Noise, 20MHz BW	
12V & 15V	60mV RMS, 120mV pk-pk max.
24V & 28V	100mV RMS, 280mV pk-pk max.
48V	200mV RMS, 480mV pk-pk max.
Temperature Coefficient	±0.03%/°C
Short Circuit Protection	Continuous
Line Regulation (note 1)	±0.2% max.
Load Regulation (note 2)	±0.2% max.
Over Voltage Protection Trip Range, % Vo nom.	115-140%
Current Limit	105%-200% Nominal Output
Start up time	100ms typ.

GENERAL SPECIFICATIONS

Efficiency	See Table
Isolation Voltage	Input/Output1500VDC min. Input/Case1500VDC min. Output/Case1500VDC min. 10 ⁷ ohm min.
Isolation Resistance	12V/15V 3500pF typ.
Isolation Capacitance	24V/28V/48V 2500pF typ.
Switching Frequency	200KHz typ.
Operating Case Temperature	-40°C to 100°C
Storage Temperature	-55°C to +105°C
Thermal Shutdown, Case Temperature	110°C Typ.
Humidity	95% RH max. Non condensing
MTBF	MIL-HDBK-217F, GB, 25 °C Full Load 665Khrs typ.
Dimensions	2.28 × 2.40 × 0.5 inches (57.9 × 61.0 × 12.7 mm)
Case Material	Aluminum Baseplate with Plastic Case
Weight	109 g

NOTE

1. Measured from high line to low line.
2. Measured from full load to zero load.
3. Output ripple and noise measured with 1µF tantalum (for 48Vout with 10µF aluminum), 1µF ceramic capacitor and minimum capacitor across output.
4. Logic compatibility open collector ref. to -input
Module On >3.5VDC to 75VDC or open circuit
Module Off 0 to < 1.2Vdc
5. Suffix "N" to the model number with negative logic remote On/Off
Module On 0 to < 1.2Vdc
Module Off >3.5VDC to 75VDC or open circuit
6. The input external capacitor recommend to parallel with 330µF
ESR< 0.7Ω to reduce the input ripple voltage.

CHB150W10 SERIES

150 WATT 10:1 INPUT DC-DC CONVERTERS

Features

- ◆ 150W Isolated Output
- ◆ Efficiency up to 93%
- ◆ Fixed Switching Frequency
- ◆ Input Under-Voltage Protection
- ◆ Over Temperature Protection
- ◆ Over Voltage/Current Protection
- ◆ Remote ON/OFF
- ◆ External Synchronization Function
- ◆ Bus Capacitor Pin for Hold up Time Option
- ◆ UVLO Set up Option
- ◆ Half-Brick Size Meets Industrial standard
- ◆ Safety Meets UL62368, EN62368 and IEC62368
- ◆ Shock & Vibration Meet EN50155 (EN61373)
- ◆ Fire & Smoke Meet EN45545-2

PRELIMINARY



Mechanical Dimensions

All Dimensions In Inches[mm]
 Tolerance Inches:x.xx= ±0.02, x.xxx= ±0.010
 Millimeters:x.x= ±0.5, x.xx=±0.25

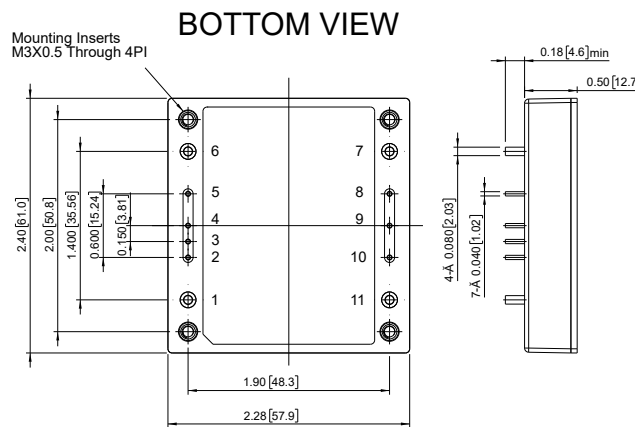

PIN CONNECTION	
PIN	Function
1	+V Input
2	UVLO
3	Sync
4	On/Off
5	BUS
6	-V Input
7	-V Output
8	-Sense
9	Trim
10	+Sense
11	+V Output

MODEL NUMBER	INPUT VOLTAGE	OUTPUT VOLTAGE	OUTPUT CURRENT		INPUT CURRENT		% EFF.		CAPACITOR LOAD MAX.
			MIN.	MAX.	NO LOAD	FULL LOAD	(2)	(3)	
CHB150W10-72S05	16.5-140VDC	5 VDC	0mA	25 A	30 mA	1.93 A	90	90	25000uF
CHB150W10-72S12	16.5-140VDC	12 VDC	0mA	12.5 A	30 mA	2.31 A	90	90	12500uF
CHB150W10-72S15	16.5-140VDC	15 VDC	0mA	10 A	30 mA	2.31 A	90.5	93	10000uF
CHB150W10-72S24	16.5-140VDC	24 VDC	0mA	6.25 A	30 mA	2.37 A	88	88	6250uF
CHB150W10-72S48	16.5-140VDC	48 VDC	0mA	3.2 A	30 mA	2.37 A	90	90	2200uF

NOTE:
 1. Nominal Input Voltage 72 VDC
 2. Measured at Nominal Input Voltage
 3. Measured at 110VDC

4. An External Input Capacitor 100uF for All Models are Recommended to Reduce Input Ripple Voltage
 5. An External Bus Capacitor 240uF for All Models

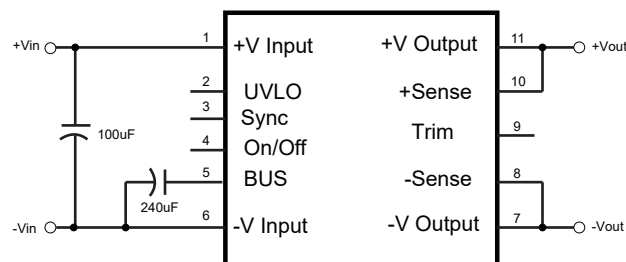

Simplified Application Circuit

Remote On/Off Control

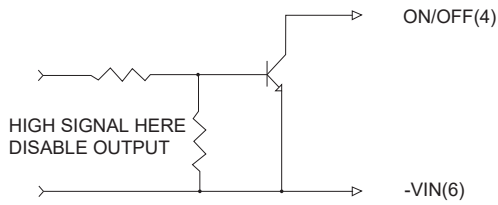

External Output Trim

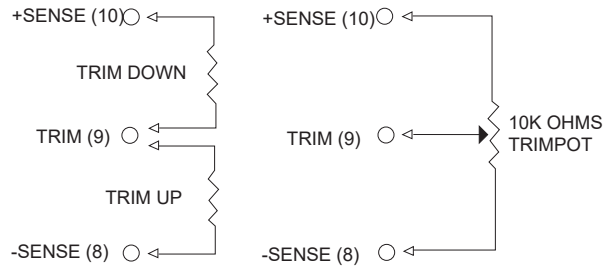

Specifications

All Specifications Typical at Nominal Line, Full Load, and 25°C Unless Otherwise Noted

INPUT SPECIFICATIONS

Input Voltage Range	72V16.5-140V
Input Over Voltage Protection	Module on.....146V Module off.....156V
Input Surge Voltage (1s max.)	156V max.
Under voltage lockout	UVLO Pin Floating 72Vin power up..... 16.0V 72Vin power down.....14.0V
Positive Logic Remote On/Off	See note 4 & 5
Input Filter (Note 6)	Pi Type

OUTPUT SPECIFICATIONS

Voltage Accuracy:	±1.0% max.
Transient Response: 75%~100% Step Load Change	
Error Band	±5% Vout Nominal,
Recovery Time	<250us
External Trim Adj. Range	+15%, -20%
Ripple & Noise, 20MHz BW (note 3)	
5V	100mV RMS max., 200mV pk-pk max.
12, 15V	150mV RMS max., 250mV pk-pk max..
24V	150mV RMS max., 250mV pk-pk max.
48V	150mV RMS max., 300mV pk-pk max.
Temperature Coefficient	±0.02%/°C
Short Circuit Protection	Continuous
Line Regulation (note 1)	±0.2%
Load Regulation (note 2)	±0.2%
Over Voltage Protection trip Range, % Vo nom.	115-140%
Current Limit	105% -140% Nominal Output.
Start up time	200ms typ.

GENERAL SPECIFICATIONS

Efficiency	See Table
Isolation Voltage	Input/Output 3000VAC min. Input/Case 3000VAC min. Output/Case 500VAC min.
Isolation Resistance	10 ⁸ ohm min.
Switching Frequency	140KHz typ.
Operating Case Temperature	-40°C to 100°C
Storage Temperature	-55°C to +125°C
Thermal Shutdown, Case Temperature	105°C typ.
Humidity	95% RH max. Non Condensing
MTBF ... MIL-HDBK-217F, GB, 25°C, Full Load	T.B.D. hrs
Dimensions	2.28x2.40x0.50 Inches (57.9x61.0x12.7 mm)
Case Material	Aluminum Baseplate with Plastic Case
Weight	T.B.D. g

NOTE

1. Measured from high line to low line
2. Measured from full load to zero load.
3. Output ripple and noise measured with 10uF tantalum and 1uF ceramic capacitor across output (48V: 10uF aluminum capacitor and 1uF ceramic capacitor across output).
4. Logic compatibility.....open collector refer to -Vin
Module on.....>3.5Vdc to +Vin or Open Circuit
Module off..... 0Vdc to 1.2Vdc
5. Suffix "N" to the model number with negative logic remote on/off
Module on.....0Vdc to 1.2Vdc
Module off.....>3.5Vdc to +Vin or Open Circuit
6. An external input capacitor 100uF for all models are recommended to reduce input ripple voltage.

CHB200 SERIES

165-200 WATT

Features

- ◆ 165W-200W Isolated Output
- ◆ Efficiency to 93%
- ◆ Fixed Switching Frequency
- ◆ Input Under-Voltage Protection
- ◆ Over Temperature Protection
- ◆ Over Voltage/Current Protection
- ◆ Remote On/Off
- ◆ Industry Standard Half-Brick Package
- ◆ Fully Isolated 1500VDC
- ◆ No Tantalum Capacitor Inside



Mechanical Dimensions

All Dimensions in Inches (mm)

Tolerance Inches: X.XX±0.02, X.XXX±0.010

Millimeters: X.X±0.5, X.XX±0.25

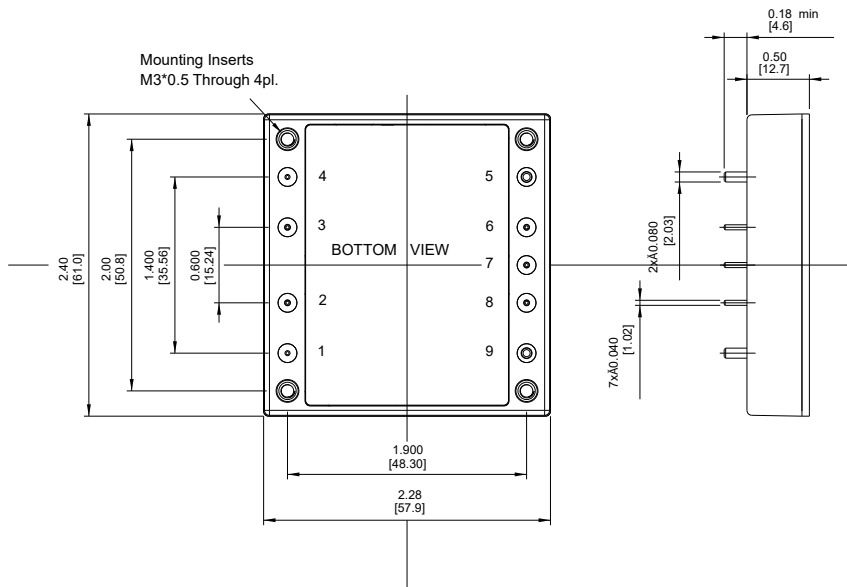

PIN CONNECTION	
PIN	Function
1	+V Input
2	On/Off
3	Case
4	-V Input
5	-V Output
6	-Sense
7	Trim
8	+Sense
9	+V Output

MODEL NUMBER	INPUT VOLTAGE	OUTPUT VOLTAGE	OUTPUT CURRENT		INPUT CURRENT		% EFF.	CAPACITOR LOAD MAX.
			MIN.	MAX.	NO LOAD	FULL LOAD		
CHB200-24S3V3	18-36 VDC	3.3 VDC	0 mA	50 A	140 mA	7.64 A	90	10000µF
CHB200-24S05	18-36 VDC	5 VDC	0 mA	40 A	240 mA	9.16 A	91	10000µF
CHB200-24S12	18-36 VDC	12 VDC	0 mA	16.7 A	230 mA	9.03 A	92.5	10000µF
CHB200-24S24	18-36 VDC	24 VDC	0 mA	8.3 A	40 mA	9.12 A	91	2200µF
CHB200-24S48	18-36 VDC	48 VDC	0 mA	4.2 A	70 mA	9.23 A	91	2000µF
CHB200-48S3V3	36-75 VDC	3.3 VDC	0 mA	50 A	80 mA	3.80 A	90.5	10000µF
CHB200-48S05	36-75 VDC	5 VDC	0 mA	40 A	120 mA	4.55 A	91.5	10000µF
CHB200-48S12	36-75 VDC	12 VDC	0 mA	16.7 A	90 mA	4.49 A	93	10000µF
CHB200-48S24	36-75 VDC	24 VDC	0 mA	8.3 A	50 mA	4.56 A	91	2200µF
CHB200-48S48	36-75 VDC	48 VDC	0 mA	4.2 A	60 mA	4.59 A	91.5	2000µF

NOTE:

1. Nominal Input Voltage 24, 48 VDC

2. The output terminal of 48Vout models required a minimum capacitor 47µF to maintain specified regulation.

Remote On/Off Control

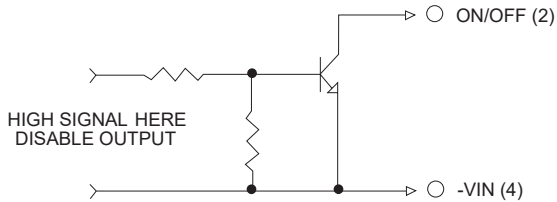

External Output Trim

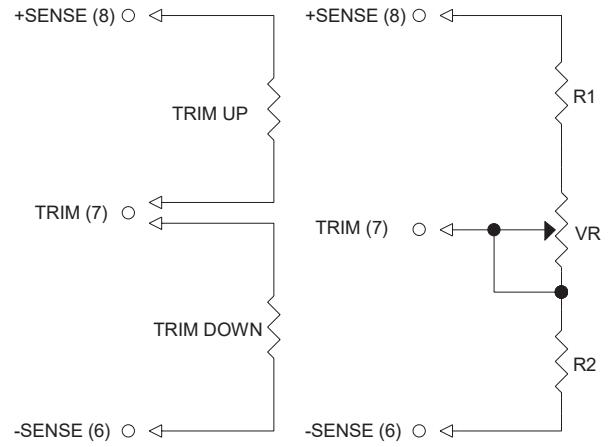

Specifications

All Specifications Typical At Nominal Line, Full Load, and 25°C Unless Otherwise Noted

INPUT SPECIFICATIONS

Input Voltage Range	24V 18-36V	48V 36-75V
Input Surge Voltage (100ms max.)	24V 50Vdc max.	48V 100Vdc max.
Under voltage lockout	24Vin	power up 17V power down 16V
	48Vin	power up 35V power down 33V
Positive Logic Remote On/Off:		
Logic Compatibility	Open Collector ref to -Input	
Module On	3.5Vdc to 75Vdc or	
	Open Circuit	
Module Off	0 to < 1.2Vdc	
Input Filter	PI Type	

OUTPUT SPECIFICATIONS

Voltage Accuracy:	±1.0% max.
Transient Response:25% Step Load Change	< 500µs
External Trim Adj. Range (note 5)	±10%
Ripple & Noise, 20MHz BW	
3.3V & 5V	40mV RMS, 100mV pk-pk max.,
12V	60mV RMS, 120mV pk-pk max.
24V	100mV RMS, 240mV pk-pk max.
48V	200mV RMS, 480mV pk-pk, max.
Temperature Coefficient	±0.03%/°C
Short Circuit Protection	Continuous
Line Regulation (note 1)	±0.2% max.
Load Regulation (note 2)	±0.2% max.
Over Voltage Protection trip Range, % Vo nom.	115-140%
Current Limit	105% -140% Nominal Output
Start up time	150ms typ.

GENERAL SPECIFICATIONS

Efficiency	See Table
Isolation Voltage	Input/Output 1500VDC min. Input/Case 1500VDC min. Output/Case 1500VDC min. 10 ⁷ ohm min.
Isolation Resistance	1000pF typ.
Isolation Capacitance	
Switching Frequency	3V3 200KHz typ. 5V 300KHz typ. 12V&24V&48V 330KHz typ.
Operating Case Temperature	-40°C to 100°C
Storage Temperature	-55°C to +105°C
Thermal Shutdown, Case Temp	110°C typ.
Humidity	95% RH max. Non condensing
Dimensions	2.28 × 2.40 × 0.52 inches (57.9 × 61.0 × 13.2 mm)
Case Material	Aluminum Baseplate with Plastic Case
Weight	114 g

NOTE

1. Measured from high line to low line.
2. Measured from full load to zero load.
3. Output ripple and noise measured with 10µF tantalum and 1µF ceramic capacitor across output.
4. Suffix "N" to the model number with negative logic remote On/Off
Module On 0 to < 1.2Vdc
Module Off >3.5VDC to 75VDC or open circuit
5. Trim-up.....connect a resistor between the trim pin and +Sense.
Trim-down.....connect a resistor between the trim pin and -Sense.
6. The input terminal recommend to parallel with 100µF for 48Vin and 220µF for 24Vin ESR<0.7Ω to reduce the input ripple voltage.

CHB200W SERIES

132-200 WATT, 4:1 INPUT RANGE

Features

- ◆ 132W-200W Isolated Output
- ◆ Half Brick Package
- ◆ 4 : 1 Input Range
- ◆ Regulated Output
- ◆ Efficiency to 89%
- ◆ Input Under Voltage Protection
- ◆ Over Temperature Protection
- ◆ Over Voltage/Current Protection
- ◆ Remote On/Off Control
- ◆ 1500VDC Isolation
- ◆ Continuous Short Circuit Protection
- ◆ UL60950-1 Approval (Except 28 Vout)



Mechanical Dimensions

All Dimensions in Inches (mm)
 Tolerance Inches: X.XX=±0.02 , X.XXX=±0.010
 Millimeters: X.X=±0.5 , X.XX=±0.25

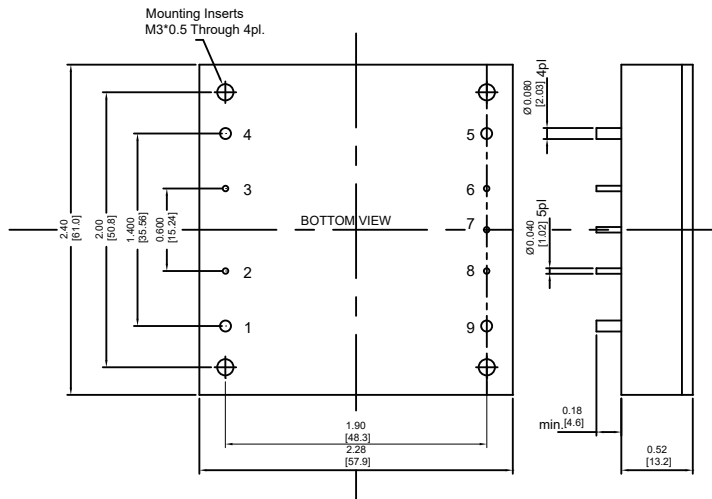

PIN CONNECTION	
PIN	Function
1	+V Input
2	On/Off
3	Case
4	-V Input
5	-V Output
6	-Sense
7	Trim
8	+Sense
9	+V Output

MODEL NUMBER	INPUT VOLTAGE	OUTPUT VOLTAGE	OUTPUT CURRENT		INPUT CURRENT		% EFF.	CAPACITOR LOAD MAX.
			MIN.	MAX.	NO LOAD	FULL LOAD		
CHB200W-24S3V3	10-36 VDC	3.3VDC	0 mA	50 A	130 mA	7.90 A	87	10000µF
CHB200W-24S05	10-36 VDC	5.0VDC	0 mA	40 A	150 mA	9.58 A	87	10000µF
CHB200W-24S12	10-36 VDC	12 VDC	0 mA	16.7 A	50 mA	9.71 A	86	2200µF
CHB200W-24S15	10-36 VDC	15 VDC	0 mA	13.3 A	50 mA	9.56 A	87	2200µF
CHB200W-24S24	10-36 VDC	24 VDC	0 mA	8.3 A	45 mA	9.54 A	87	2200µF
CHB200W-24S28	10-36 VDC	28 VDC	0 mA	7.14 A	55 mA	9.41 A	88.5	2200µF ⁽²⁾
CHB200W-24S48	10-36 VDC	48 VDC	0 mA	4.2 A	60 mA	9.77 A	86	2200µF ⁽³⁾
CHB200W-48S3V3	18-75 VDC	3.3VDC	0 mA	40 A	80 mA	3.13 A	88	10000µF
CHB200W-48S05	18-75 VDC	5.0VDC	0 mA	40 A	80 mA	4.68 A	89	10000µF
CHB200W-48S12	18-75 VDC	12 VDC	0 mA	16.7 A	60 mA	4.74 A	88	2200µF
CHB200W-48S15	18-75 VDC	15 VDC	0 mA	13.3 A	60 mA	4.72 A	88	2200µF
CHB200W-48S24	18-75 VDC	24 VDC	0 mA	8.3 A	60 mA	4.72 A	88	2200µF
CHB200W-48S28	18-75 VDC	28 VDC	0 mA	7.14 A	50 mA	4.68 A	89	2200µF ⁽²⁾
CHB200W-48S48	18-75 VDC	48 VDC	0 mA	4.2 A	50 mA	4.83 A	87	2200µF ⁽³⁾

NOTE:

1. Nominal Input Voltage 24, 48 VDC
2. The Output Terminal of 28Vout Models Required a Minimum Capacitor 100uF to Maintain Specified Regulation.
3. The Output Terminal of 48Vout Models Required a Minimum Capacitor 47uF to Maintain Specified Regulation.

Remote On/Off Control

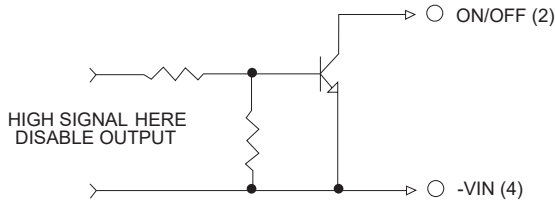

External Output Trim

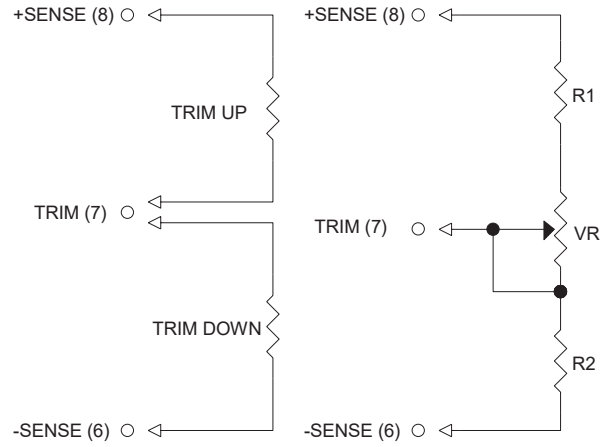

Specifications

All Specifications Typical At Nominal Line, Full Load, and 25°C Unless Otherwise Noted

INPUT SPECIFICATIONS

Input Voltage Range	24V 10-36V	48V 18-75V
Input Surge Voltage (100ms max.)	24V 50Vdc max.	48V 100Vdc max.
Under Voltage Lockout	24Vin	power up 9.5V
	48Vin	power down 8.5V
Positive Logic Remote On/Off		power up 17V
Input Filter		power down 16V
		See note 4 & 5
		Pi Type

OUTPUT SPECIFICATIONS

Voltage Accuracy	±1.0% max.
Transient Response: 25% Step Load Change	< 500µs
External Trim Adj. Range (note 6)	±10%
Ripple & Noise, 20MHz BW (note 3)	
3.3V & 5V	40mV RMS max., 100mV pk-pk max.
12V & 15V	60mV RMS max., 150mV pk-pk max.
24V	100mV RMS max., 240mV pk-pk max.
28V	100mV RMS max., 280mV pk-pk max.
48V	150mV RMS max., 480mV pk-pk max.
Temperature Coefficient	±0.03%/°C
Short Circuit Protection	Continuous
Line Regulation (note 1)	±0.2% max.
Load Regulation (note 2)	±0.2% max.
Over Voltage Protection Trip Range, % Vo nom.	115-140%
Current Limit	110%-150% Nominal Output
Start up time	120ms typ.

GENERAL SPECIFICATIONS

Efficiency	See Table
Isolation Voltage	Input/Output..... 1500VDC min.
	Input/Case..... 1500VDC min.
	Output/Case 1500VDC min.
	10 ⁷ ohm min.
Isolation Resistance	2000pF typ.
Isolation Capacitance	250KHz typ.
Switching Frequency	-40°C to 100°C
Operating Case Temperature	-55°C to +105°C
Storage Temperature	110°C typ.
Thermal Shutdown Case Temp.	95% RH max. Non condensing
Humidity	600Khrs typ.
MTBF MIL-STD-217F, GB, 25°C, Full Load	2.28 x 2.40 x 0.52 inches
Dimensions	(57.9 x 61.0 x 13.2 mm)
Case Material	Aluminum Baseplate with
	Plastic Case
Weight	114 g

NOTE

- Measured from high line to low line.
- Measured from full load to zero load.
- Output ripple and noise measured with 10µF tantalum and 1µF ceramic capacitor across output. (48V: 10µF aluminum and 1µF ceramic capacitor across output)
- Logic compatibility open collector ref to -Input
 Module On >3.5VDC to 75VDC or open circuit
 Module Off 0 to < 1.2VDC
- Suffix "N" to the model number with negative logic remote On/Off
 Module On 0 to < 1.2VDC
 Module Off >3.5VDC to 75VDC or open circuit
- Trim-up connect a resistor between the trim pin and +sense
 Trim-down connect a resistor between the trim pin and -sense
- Suffix "-C" to the model number with clear mounting insert. (3.2mm DIA.)
- An external input capacitor 470µF for 24Vin or 47µF for 48Vin models are recommended to reduce input ripple voltage.

CHB200W-110S SERIES

200 WATT 4:1 INPUT DC-DC CONVERTERS

Features

- ◆ 200W Isolated Output
- ◆ Efficiency to 91%
- ◆ Low No Load Power Consumption
- ◆ Fixed Switching Frequency
- ◆ 4:1 Input Range
- ◆ Regulated Outputs
- ◆ Input Under-Voltage Protection
- ◆ Over Temperature Protection
- ◆ Over Voltage/Current Protection
- ◆ Remote On/Off
- ◆ Half-Brick Size Meets Industrial standard
- ◆ Safety Meets UL60950-1 2nd (Basic Insulation)
- ◆ Meets EN50155 With External Circuits
- ◆ Shock & Vibration Meet EN50155 (EN61373)
- ◆ Fire & Smoke meet EN45545-2
- ◆ 5000m Operating Altitude



Mechanical Dimensions

CASE HB

All Dimensions In Inches(mm)

Tolerances Inches: X.XX= ±0.02 , X.XXX= ±0.010

Millimeters: X.X= ±0.5 , X.XX=±0.25

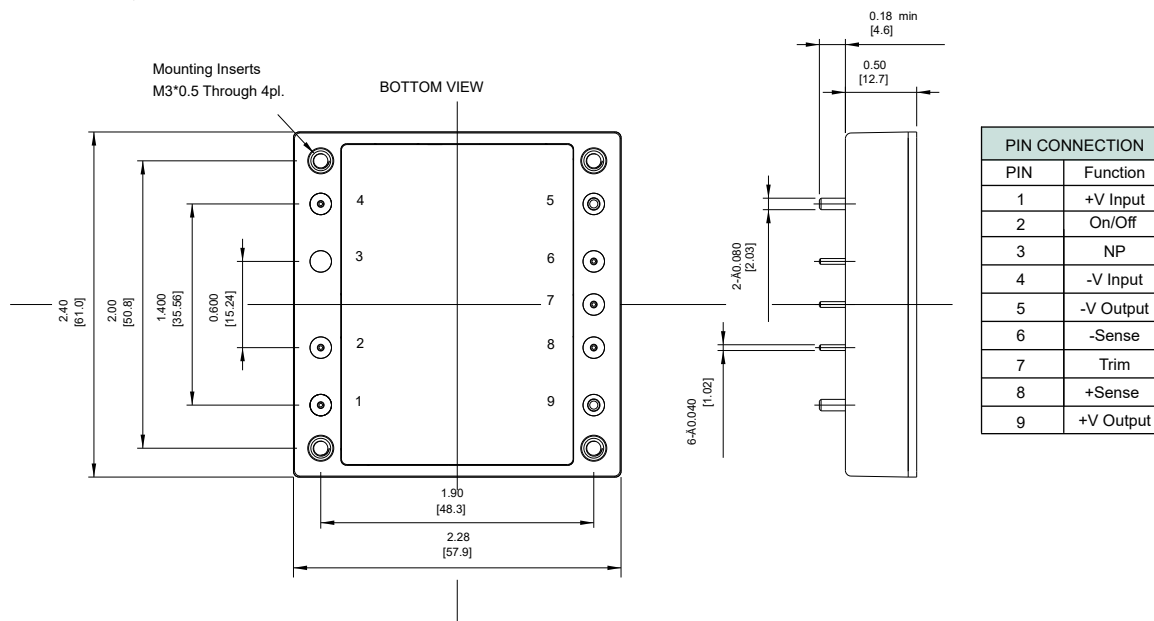

MODEL NUMBER	INPUT VOLTAGE	OUTPUT VOLTAGE	OUTPUT CURRENT		INPUT CURRENT		% EFF. (2)	CAPACITOR LOAD MAX.
			MIN.	MAX.	NO LOAD	FULL LOAD		
CHB200W-110S05	43-160 VDC	5 VDC	0mA	40 A	10 mA	2066 mA	88	40000uF
CHB200W-110S12	43-160 VDC	12 VDC	0mA	16.7 A	10 mA	2024 mA	90	16700uF
CHB200W-110S24	43-160 VDC	24 VDC	0mA	8.3 A	10 mA	2034 mA	89	8300uF
CHB200W-110S28	43-160 VDC	28 VDC	0mA	7.14 A	10 mA	2042 mA	89	7140uF
CHB200W-110S48	43-160 VDC	48 VDC	0mA	4.2 A	10 mA	2014 mA	91	3000uF

NOTE:

1. Nominal Input Voltage 110 VDC.

2. Measure at Nominal Input Voltage.

3. An external input capacitor 220uF for all models are Recommended to Reduce Input Ripple Voltage.

Remote On/Off Control

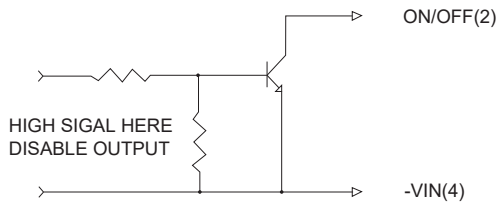

External Output Trim

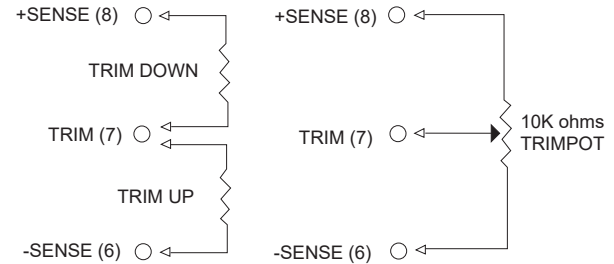

Specifications

All Specifications Typical At Nominal Line, Full Load, and 25°C Unless Otherwise Noted

INPUT SPECIFICATIONS

Input Voltage Range	110V.....43-160V
Input Surge Voltage (100ms max.)	110V.....200Vdc max.
Under Voltage Lockout	110Vin Power Up.....42V
	110Vin Power Down.....39V
Positive Logic Remote ON/OFF	See note 4 & 5
Input Filter (note 6)	Pi Type

OUTPUT SPECIFICATIONS

Voltage Accuracy:	±1.0% max.
Transient Response: 75%~100% Step Load Change	
Error Band	±5% Vout nominal,
Recovery Time	<250us
External Trim Adj. Range	+10%
Ripple & Noise, 20MHz BW (note 3)	
5V	60mV RMS, 120mV pk-pk max.
12V	80mV RMS, 150mV pk-pk max.
24V	120mV RMS, 240mV pk-pk max.
28V	140mV RMS, 280mV pk-pk max.
48V	220mV RMS, 480mV pk-pk max.
Temperature Coefficient	±0.02%/°C max
Short Circuit Protection	Continuous
Line Regulation (note 1)	±0.2% max
Load Regulation (note 2)	±0.2% max
Over Voltage Protection trip Range, % Vo nom.	115 - 140%
Current Limit	110% -160% Nominal Output.
Start up time	35ms typ.

GENERAL SPECIFICATIONS

Efficiency	See Table
Isolation Voltage	Input/Output 3000VDC min.
	Input/Case 3000VDC min.
	Output/Case 500VAC min.
	10 ⁸ ohm min.
Isolation Resistance	3000pF typ.
Isolation Capacitance	300KHz typ
Switching Frequency	-40°C to 100°C
Operating Case Temperature	-55°C to +125°C
Storage Temperature	110°C typ.
Thermal Shutdown, Case Temperature	95% RH max. Non condensing
Humidity	48V TBDKhrs typ.
MTBF ... MIL-HDBK-217F, GB, 25°C, Full Load	Others..... TBDKhrs typ.
	Meet UL60950-1 2 nd (Basic Insulation)
Safety	Meet EN50155 (EN50121-3-2)
EMC (note7)	with External Filter.
	Meet EN50155(EN61373)
Shock/Vibration	Meet EN50155(EN60068-2-1,2,30).
Environmental	Meet EN45545-2
Fire & Smoke	2.28x2.40x0.50 inches
Dimensions	(57.9x61.0x12.7 mm)
	Aluminum Baseplate with Plastic Case
Case Material	114g
Weight	

NOTE

1. Measured from high line to low line.
2. Measured from full load to zero load.
3. Output ripple and noise measured with 10uF aluminum solid capacitor and 1uF ceramic capacitor across output. (5V: 47uF polymer tantalum capacitor and 1uF ceramic capacitor across output).
4. Logic compatibility open collector ref to -Input
Module on..... >3.5Vdc to 160Vdc or open circuit
Module off 0 to <1.2Vdc
5. Suffix "N" to the model number with negative logic remote on/off
Module on 0 to <1.2Vdc
Module off >3.5Vdc to 160Vdc or open circuit
6. An external input capacitor 220uF for all models are recommended to reduce input ripple voltage.
7. For information about EN50155 and RIA12, refer to application note.
8. Suffix "-C" to the model number with clear mounting insert. (3.2mm DIA).

CHB200W10 SERIES

200 WATT 10:1 INPUT DC-DC CONVERTERS

Features

- ◆ 200W Isolated Output
- ◆ Efficiency to 93%
- ◆ Fixed Switching Frequency
- ◆ Input Under-Voltage Protection
- ◆ Over Temperature Protection
- ◆ Over Voltage/Current Protection
- ◆ Remote On/Off
- ◆ External Synchronization Function
- ◆ Bus Capacitor Pin for Hold Up Time Option
- ◆ UVLO Set Up Option
- ◆ Half-Brick size meets Industrial standard
- ◆ Safety Meets UL62368, EN62368 and IEC62368
- ◆ Shock & Vibration Meet EN50155 (EN61373)
- ◆ Fire & Smoke Meet EN45545-2

PRELIMINARY



Mechanical Dimensions

All Dimensions In Inches[mm]
 Tolerance Inches:x.xx= ±0.02, x.xxx= ±0.010
 Millimeters:x.x= ±0.5, x.xx=±0.25

Mounting Inserts
 M3X0.5 Through 4PI

BOTTOM VIEW

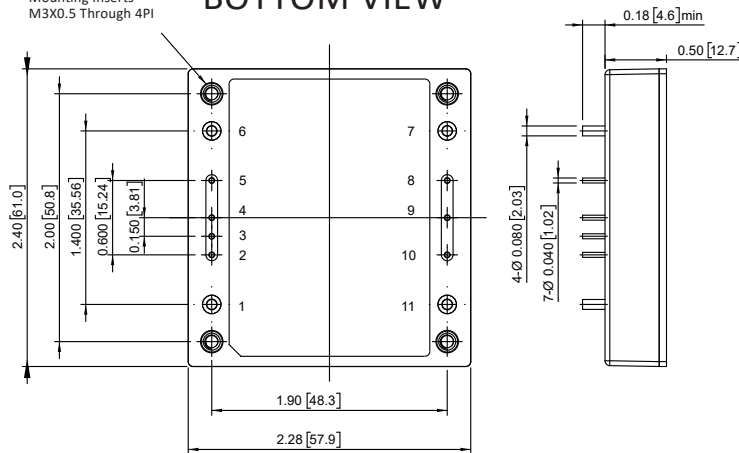

PIN CONNECTION	
PIN	Function
1	+V Input
2	UVLO
3	Sync
4	On/Off
5	BUS
6	-V Input
7	-V Output
8	-Sense
9	Trim
10	+Sense
11	+V Output

MODEL NUMBER	INPUT VOLTAGE	OUTPUT VOLTAGE	OUTPUT CURRENT		INPUT CURRENT		% EFF.		CAPACITOR LOAD MAX.
			MIN.	MAX.	NO LOAD	FULL LOAD	(2)	(3)	
CHB200W10-72S05	16.5-140VDC	5 VDC	0mA	40 A	20 mA	3.09 A	90	90	40000uF
CHB200W10-72S12	16.5-140VDC	12 VDC	0mA	16.7 A	20 mA	3.09 A	90	90	16700uF
CHB200W10-72S15	16.5-140VDC	15 VDC	0mA	13.5A	20 mA	3.07 A	91.5	93	13500uF
CHB200W10-72S24	16.5-140VDC	24 VDC	0mA	8.5 A	20 mA	3.22 A	88	88	8000uF
CHB200W10-72S48	16.5-140VDC	48 VDC	0mA	4.2 A	20 mA	3.11 A	90	90	4000uF

NOTE:

1. Nominal Input Voltage 72 VDC
2. Measured at Nominal Input Voltage
3. Measured at 110VDC
4. An External Input Capacitor 100uF for All Models are Recommended to Reduce Input Ripple Voltage
5. An External Bus Capacitor 240uF for All Models

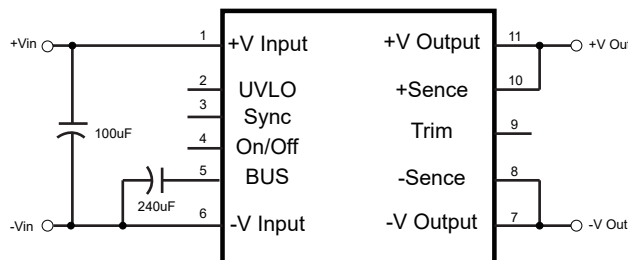

Simplified Application Circuit

Remote On/Off Control

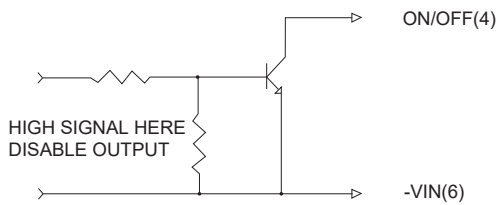

External Output Trim

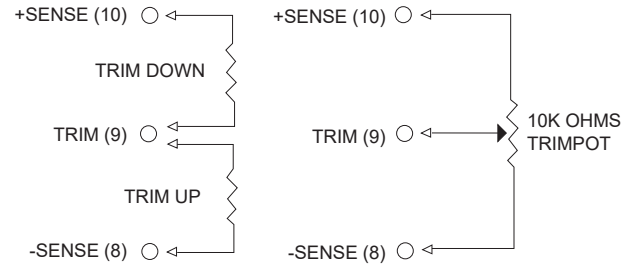

Specifications

All Specifications Typical at Nominal Line, Full Load, and 25°C Unless Otherwise Noted

INPUT SPECIFICATIONS

Input Voltage Range	72V.....16.5-140V
Input Over Voltage Protection	Module on.....146V Module off.....156V
Input Surge Voltage (1s max.)	156V max
Under Voltage Lockout	UVLO Pin Floating 72Vin power up.....16.0V 72Vin power down.....14.0V
Positive Logic Remote ON/OFF	See note 4 & 5
Input Filter (note 6)	Pi Type

OUTPUT SPECIFICATIONS

Voltage Accuracy:	±1.0% max.
Transient Response: 75%~100% Step Load Change	
Error Band	±5% Vout Nominal,
Recovery Time	<250us
External Trim Adj. Range	+15%,-20%
Ripple & Noise, 20MHz BW (note 3)	
5V	100mV RMS max., 200mV pk-pk max.
12, 15V	150mV RMS max., 250mV pk-pk max.
24V	150mV RMS max., 300mV pk-pk max.
48V	150mV RMS max., 350mV pk-pk max.
Temperature Coefficient	±0.02%/°C max
Short Circuit Protection	Continuous
Line Regulation (note 1)	±0.2% max
Load Regulation (note 2)	±0.2% max
Over Voltage Protection trip Range, % Vo nom.	115 - 140%
Current Limit	105% ~140% Nominal Output
Start up time	200ms typ.

GENERAL SPECIFICATIONS

Efficiency	See Table
Isolation Voltage	Input/Output 3000VAC min. Input/Case 3000VAC min. Output/Case 500VAC min.
Isolation Resistance	10 ⁸ ohm min.
Switching Frequency	140KHz typ.
Operating Case Temperature	-40°C to 100°C
Storage Temperature	-55°C to +125°C
Thermal Shutdown, Case Temperature	105°C typ.
Humidity	95% RH max. Non Condensing
MTBF ... MIL-HDBK-217F, GB, 25°C, Full Load	T. B. D. hrs
Dimensions	2.28x2.40x0.50 Inches (57.9x61.0x12.7 mm)
Case Material	Aluminum Baseplate with Plastic Case
Weight	T. B. D. g

NOTE

1. Measured from high line to low line
2. Measured from full load to zero load
3. Output ripple and noise measured with 10uF tantalum and 1uF ceramic capacitor across output
(48V: 10uF aluminum capacitor and 1uF ceramic capacitor across output).
4. Logic compatibility.....open collector refer to -Vin
Module on.....>3.5Vdc to +Vin or Open Circuit
Module off..... 0Vdc to 1.2Vdc
5. Suffix "N" to the model number with negative logic remote on/off
Module on.....0Vdc to 1.2Vdc
Module off.....>3.5Vdc to +Vin or Open Circuit
6. An external input capacitor 100uF for all models are recommended to reduce input ripple voltage.

CHB300W SERIES

300 WATT, 4:1 INPUT RANGE

Features

- ◆ 300W Isolated Output
- ◆ Efficiency to 92%
- ◆ Fixed Switching Frequency
- ◆ Input Under Voltage Protection
- ◆ Over Temperature Protection
- ◆ Over Voltage/Current Protection
- ◆ Remote On/Off
- ◆ Industry Standard Half-Brick Package
- ◆ Fully Isolated 1500VDC
- ◆ UL60950-1 2nd Approval



Mechanical Dimensions

All Dimensions in Inches (mm)
 Tolerance Inches: X.XX=±0.02, X.XXX=±0.010
 Millimeters: X.X=±0.5, X.XX=±0.25

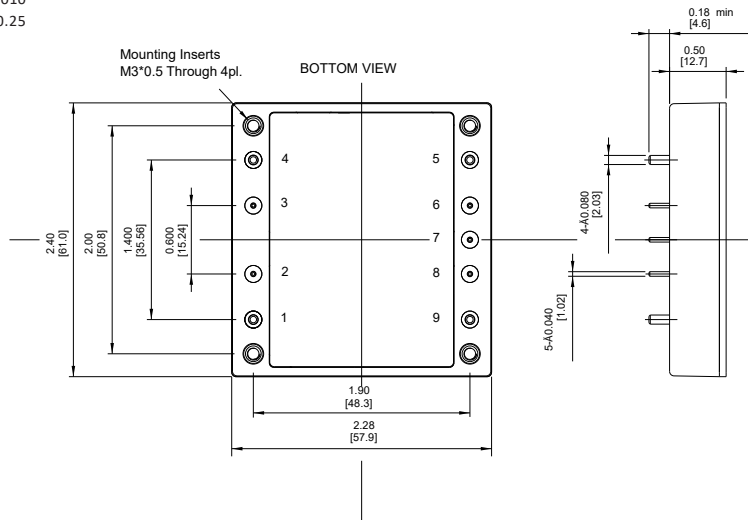

PIN CONNECTION	
PIN	Function
1	+V Input
2	On/Off
3	Case
4	-V Input
5	-V Output
6	-Sense
7	Trim
8	+Sense
9	+V Output

MODEL NUMBER	INPUT VOLTAGE	OUTPUT VOLTAGE	OUTPUT CURRENT		INPUT CURRENT		% EFF.		CAPACITOR LOAD MAX.
			MIN.	MAX.	NO LOAD	FULL LOAD	(2)	(3)	
CHB300W-24S05	9-36 VDC	5 VDC	0 mA	60 A	200 mA	14.12 A	88	88.5	470-10000µF
CHB300W-24S12	9-36 VDC	12 VDC	0 mA	25 A	200 mA	13.74 A	91	91	330-10000µF
CHB300W-24S15	9-36 VDC	15 VDC	0 mA	20 A	250 mA	13.74 A	91	91	0-10000µF
CHB300W-24S24	9-36 VDC	24 VDC	0 mA	12.5 A	80 mA	14.20 A	88	88	220-4700µF
CHB300W-24S28	9-36 VDC	28 VDC	0 mA	10.7 A	80 mA	14.12 A	88.5	88.5	220-4700µF
CHB300W-24S48	9-36 VDC	48 VDC	0 mA	6.25 A	100 mA	14.20 A	88	88	220-2200µF
CHB300W-48S05	18-75 VDC	5 VDC	0 mA	60 A	100 mA	6.94 A	89	90	0-10000µF
CHB300W-48S12	18-75 VDC	12 VDC	0 mA	25 A	100 mA	6.94 A	92	92	0-10000µF
CHB300W-48S15	18-75 VDC	15 VDC	0 mA	20 A	130 mA	6.80 A	92	92	0-10000µF
CHB300W-48S24	18-75 VDC	24 VDC	0 mA	12.5 A	60 mA	6.98 A	90	89	0-4700µF
CHB300W-48S28	18-75 VDC	28 VDC	0 mA	10.7 A	60 mA	6.94 A	91	89.5	0-4700µF
CHB300W-48S48	18-75 VDC	48 VDC	0 mA	6.25 A	80 mA	7.02 A	90	89	220-2200µF

NOTE:

1. Nominal Input Voltage 24,48 VDC
2. Measure at 12VDC for 24Sxx and 24VDC for 48Sxx Models
3. Measure at Nominal Input Voltage
4. The Output Terminal of Models Required a Minimum Capacitor to Maintain Specified Regulation
5. Output Peak Power 350W < 3 seconds with Maximum Duty Cycle of 10%, Average Output Power not to Exceed 300W.

Remote On/Off Control

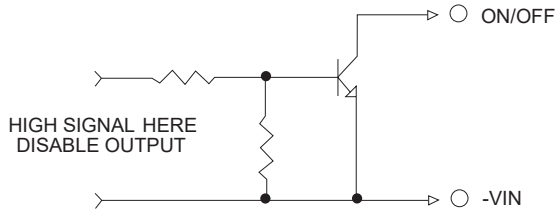

External Output Trim

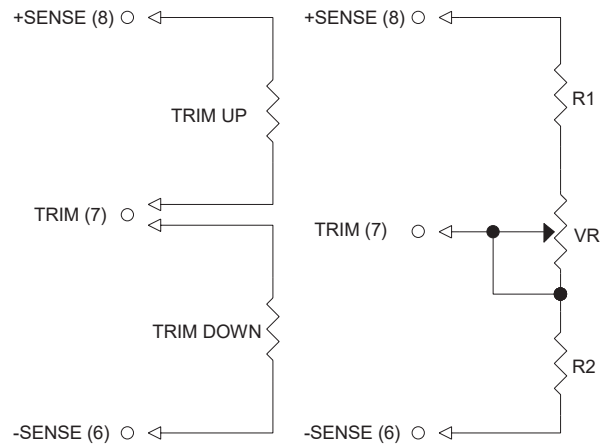

Specifications

All Specifications Typical At Nominal Line, Full Load, and 25°C Unless Otherwise Noted

INPUT SPECIFICATIONS

Input Voltage Range	24V..... 9-36V 48V 18-75V
Input Surge Voltage (100ms max.)	24V 50Vdc max. 48V 100Vdc max.
Under Voltage Lockout	24Vin power up 8.8V power down 8.0V 48Vin power up 17V power down 16V
Positive Logic Remote On/Off	See note 4 & 5
Input Filter	24SXX and 48S15..... LC Type Other 48SXX Pi Type

OUTPUT SPECIFICATIONS

Voltage Accuracy	±1.0% max.
Transient Response: 25% Step Load Change	< 500µs
External Trim Adj. Range (note 6)	±10%
Ripple & Noise, 20MHz BW (note 3)	
5.0V	40mV RMS, 100mV pk-pk max.
12V	60mV RMS, 120mV pk-pk max.
15V	80mV RMS, 200mV pk-pk max.
24V & 28V	100mV RMS, 280mV pk-pk max.
48V	200mV RMS, 480mV pk-pk max.
Temperature Coefficient	±0.03%/°C
Short Circuit Protection	Continuous
Line Regulation (note 1)	±0.2% max.
Load Regulation (note 2)	±0.2% max.
Over Voltage Protection Trip Range, % Vo nom.	115-140%
Current Limit	120%-160% Nominal Output
Start up time	120ms typ.

GENERAL SPECIFICATIONS

Efficiency	See Table
Isolation Voltage	Input/Output 1500VDC min. Input/Case 1500VDC min. Output/Case 1500VDC min.
Isolation Resistance	10 ⁷ ohm min.
Isolation Capacitance	2000pF typ.
Switching Frequency	220KHz typ.
Operating Case Temperature	-40°C to 100°C
Storage Temperature	-55°C to +105°C
Thermal Shutdown Case Temperature	110°C typ.
Humidity	95% RH max. Non condensing
MTBF MIL-STD-217F, GB, 25°C, Full Load	600Khrs
Dimensions	2.28 x 2.40 x 0.50 inches (57.9 x 61.0 x 12.7 mm)
Case Material	Aluminum Baseplate with Plastic Case
Weight	114 g

NOTE

1. Measured from high line to low line.
2. Measured from full load to zero load.
3. The output ripple and noise measurement with 10µF tantalum (for 24S05 with 330µF tantalum, 24S12 with 100µF tantalum and 48Vout with 10µF aluminum) 1uF ceramic capacitor and minimum capacitor across output,
4. Logic compatibility open collector ref. to -input
Module On >3.5VDC to 75VDC or open circuit
Module Off 0 to < 1.2VDC
5. Suffix "N" to the model number with negative logic remote On/Off.
Module On 0 to < 1.2VDC
Module Off >3.5VDC to 75VDC or open circuit
6. Trim-up.....connect a resistor between the trim pin and +sense.
Trim-down.....connect a resistor between the trim pin and -sense.
7. The input terminal recommend to parallel with 1000µF for 24Vin, 470µF for 48S15 model and 220µF for other 48Vin models ESR< 0.7Ω to reduce the input ripple voltage.
8. Suffix "-C" to the model number with clear mounting insert. (3.2mm DIA)

CHB300W-110S SERIES

300 WATT, INPUT RANGE 43-160 VDC

Features

- ◆ 198-300W Isolated Output
- ◆ Efficiency to 91%
- ◆ Low No Load Power Consumption
- ◆ Fixed Switching Frequency
- ◆ 4 : 1 Input Range
- ◆ Regulated Outputs
- ◆ Input Under-Voltage Protection
- ◆ Over Temperature Protection
- ◆ Over Voltage/Current Protection
- ◆ Remote On/Off
- ◆ Half-Brick Size Meets Industrial Standard
- ◆ UL60950-1 2nd (Basic Insulation) Approval (Except 3.3Vout)
- ◆ CB Test Certificate IEC60950-1 (Except 3.3Vout)
- ◆ Meets EN50155 With External Circuits
- ◆ Shock & Vibration Meet EN50155 (EN61373)
- ◆ Fire & Smoke Meet EN45545-2
- ◆ 5000m Operating Altitude



Mechanical Dimensions

All Dimensions in Inches (mm)
 Tolerance Inches: X.XX±0.02, X.XXX±0.010
 Millimeters: X.X±0.5, X.XX±0.25

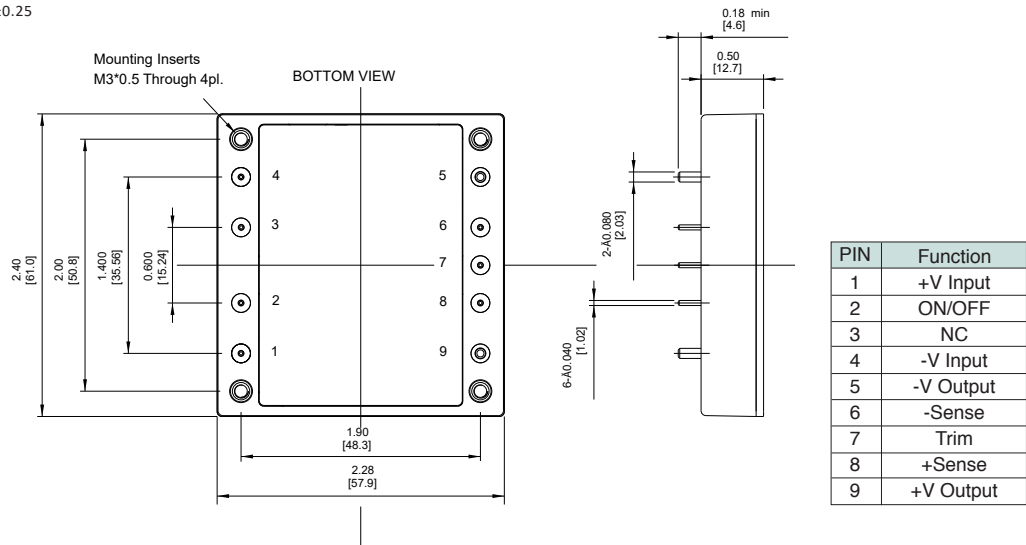

MODEL NUMBER	INPUT VOLTAGE	OUTPUT VOLTAGE	OUTPUT CURRENT		INPUT CURRENT		% EFF. (2)	CAPACITOR LOAD MAX.
			MIN.	MAX.	NO LOAD	FULL LOAD		
CHB300W-110S3V3	43-160 VDC	3.3 VDC	0 mA	60 A	10 mA	2093 mA	86	60000µF
CHB300W-110S05	43-160 VDC	5 VDC	0 mA	60 A	10 mA	3099 mA	88	60000µF
CHB300W-110S12	43-160 VDC	12 VDC	0 mA	25 A	10 mA	3030 mA	90	25000µF
CHB300W-110S24	43-160 VDC	24 VDC	0 mA	12.5 A	10 mA	3064 mA	89	12500µF
CHB300W-110S28	43-160 VDC	28 VDC	0 mA	10.7 A	10 mA	3064 mA	89	10700µF
CHB300W-110S48	43-160 VDC	48 VDC	0 mA	6.25 A	10 mA	2997 mA	91	4700µF

NOTE:

1. Nominal Input Voltage 110 VDC.
2. Measure at Nominal Input Voltage.

Remote On/Off Control

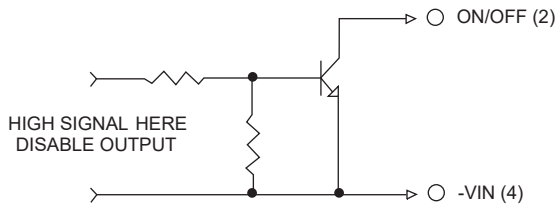

External Output Trim

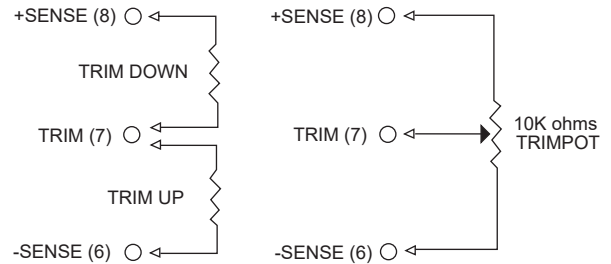

Specifications

All Specifications Typical At Nominal Line, Full Load, and 25°C Unless Otherwise Noted

INPUT SPECIFICATIONS

Input Voltage Range	110V43-160V
Input Surge Voltage (100ms max.)	110V200Vdc max.
Under Voltage Lockout	110Vin power up.....42V power down..39V
Positive Logic Remote On/Off	See note 4 & 5
Input Filter(note 7)	Pi Type

OUTPUT SPECIFICATIONS

Voltage Accuracy	±1.0% max.
Transient Response: 25% Step Load Change	
Recover Time	<250µs
External Trim Adj. Range	±10%
Ripple & Noise, 20MHz BW (note 3)	
3.3 & 5V	60mV RMS, 120mV pk-pk max.
24V	80mV RMS, 150mV pk-pk max.
28V	120mV RMS, 240mV pk-pk max.
48V	140mV RMS, 280mV pk-pk max.
Temperature Coefficient	220mV RMS, 480mV pk-pk max.
Short Circuit Protection .	±0.02%/°C
Line Regulation (note 1)	Continuous
Load Regulation (note 2)	±0.2% max. ±0.2% max.
Over Voltage Protection Trip Range, % Vo nom.	115-140%
Current Limit	110%-160% Nominal Output
Start up time	35ms typ.

GENERAL SPECIFICATIONS

Efficiency	See Table
Isolation Voltage	Input/Output, Input/Case 3000VDC min. Output/Case 500VAC min.
Isolation Resistance	10 ⁸ ohm min.
Isolation Capacitance	3000pF typ.
Switching Frequency	3.3V 250KHz typ. Others300KHz typ.
Operating Case Temperature Storage	-40°C to 100°C
Temperature	-55°C to +125°C
Thermal Shutdown Case Temp.	110°C typ.
Humidity	95% RH max. Non condensing
MTBF	MIL-HDBK-217F, GB,25°C, Full Load 48V:900Khrs typ. Others:600Khrs typ.
Safety	UL60950-1 2 nd (Basic Insulation)
EMC (note 7)	EN50155 (EN50121-3-2) with External Filter EN50155 (EN61373)
Shock/Vibration	EN50155 (EN60068-2-1)
Environmental	Meet EN45545-2
Fire & Smoke	2.28 × 2.40 × 0.52 inches (57.9 × 61.0 × 13.2 mm)
Dimensions	Aluminum Baseplate with Plastic Case
Case Material	Case 114g
Weight	

NOTE

- Measured from high line to low line.
- Measured from full load to zero load.
- Output ripple and noise measured with 10µF aluminum solid capacitor and 1µF ceramic capacitor across output. (3.3V&5V: 47µF polymer tantalum capacitor and 1µF ceramic capacitor across output).
- Logic compatibility open collector ref to -input
Module On >3.5VDC to 160Vdc or Open Circuit
Module Off0 to <1.2Vdc
- Suffix "N" to the model number with negative logic remote On/Off
Module On 0 to <1.2Vdc
Module Off>3.5VDC to 160Vdc or open circuit
- An external input capacitor 220µF for all models are recommended to reduce input ripple voltage.
- For information about EN50155 and RIA12, refer to application note.
- Suffix "-C" to the model number with clear mounting insert. (3.2mm DIA).

CHB300-300S SERIES

300 WATT, INPUT RANGE 180-425 VDC

Features

- ◆ 300W Isolated Output
- ◆ Efficiency to 90%
- ◆ Fixed Switching Frequency
- ◆ Input Under-Voltage Protection
- ◆ Over Temperature Protection
- ◆ Low No Load Power Consumption
- ◆ Over Voltage/Current Protection
- ◆ Remote On/Off
- ◆ Half-Brick Size Meets Industrial Standard
- ◆ UL60950-1 2nd (Reinforced Insulation) Approval
- ◆ CB Test Certificate IEC60950-1



Mechanical Dimensions

All Dimensions in Inches (mm)

Tolerance Inches: X.XX=±0.02, X.XXX=±0.010
 Millimeters: X.X=±0.5, X.XX=±0.25

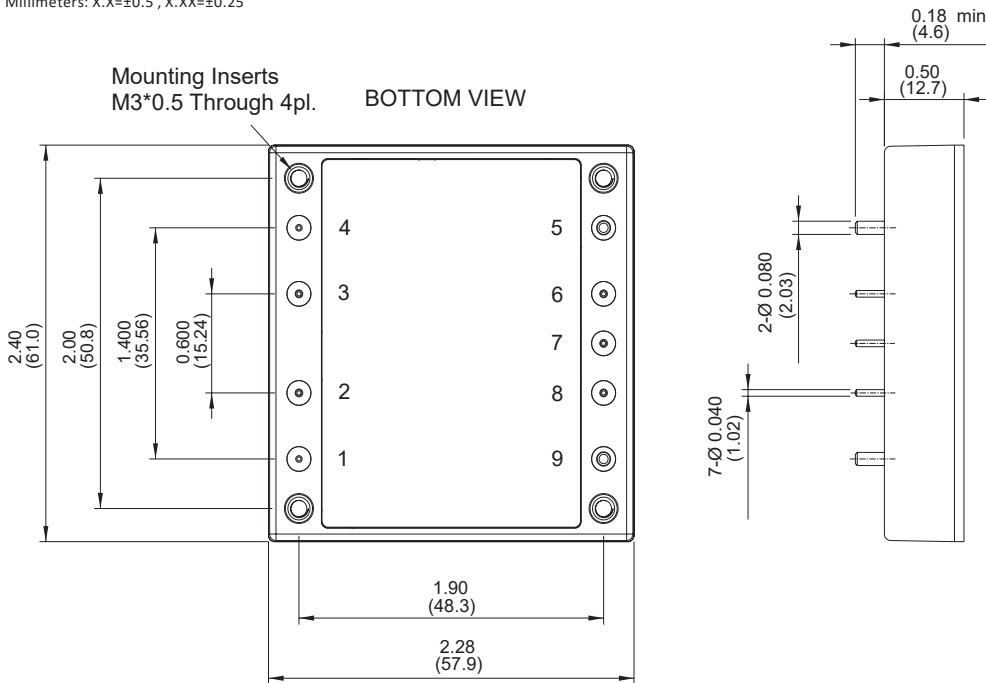

PIN	Function
1	+V Input
2	ON/OFF
3	NP
4	-V Input
5	-V Output
6	-Sense
7	Trim
8	+Sense
9	+V Output

MODEL NUMBER	INPUT VOLTAGE	OUTPUT VOLTAGE	OUTPUT CURRENT		INPUT CURRENT		% EFF.	CAPACITOR LOAD MAX.
			MIN.	MAX.	NO LOAD	FULL LOAD		
CHB300-300S05	180-425 VDC	5 VDC	0 mA	60 A	10 mA	1920 mA	89	10000µF
CHB300-300S12	180-425 VDC	12 VDC	0 mA	25 A	10 mA	1920 mA	88	10000µF
CHB300-300S24	180-425 VDC	24 VDC	0 mA	12.5 A	10 mA	1870 mA	90	6000µF
CHB300-300S28	180-425 VDC	28 VDC	0 mA	10.7 A	10 mA	1870 mA	90	6000µF
CHB300-300S48	180-425 VDC	48 VDC	0 mA	6.25 A	10 mA	1870 mA	90	3000µF

Remote On/Off Control

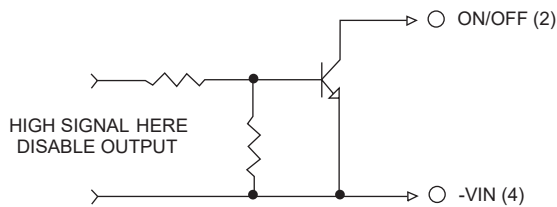

External Output Trim

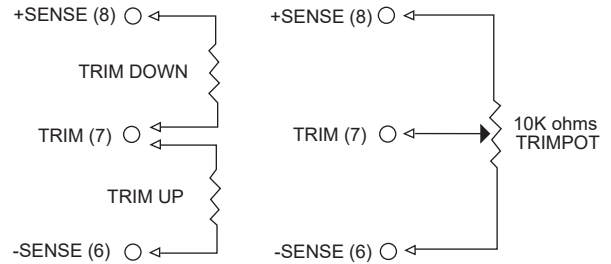

Specifications

All Specifications Typical At Nominal Line, Full Load, and 25°C Unless Otherwise Noted

INPUT SPECIFICATIONS

Input Voltage Range.	300V..... 180-425V
Under voltage lockout	300Vin power up 170V 300Vin power down.....160V
Positive Logic Remote On/Off	See note 5 & 6
Input Filter	Pi Type

OUTPUT SPECIFICATIONS

Voltage Accuracy :	±1.0% max.
Transient Response:25% Step Load Change	< 250µs
External Trim Adj. Range	+10%, -20%
Ripple & Noise, 20MHz BW (3)	
5V	60mV RMS max., 120mV pk-pk max
12V	60mV RMS max., 150mV pk-pk max.
24V	120mV RMS max., 240mV pk-pk max.
28V	150mV RMS max., 280mV pk-pk max.
48V	200mV RMS max., 480mV pk-pk max.
Temperature Coefficient	±0.02%/°C
Short Circuit Protection	Continuous
Line Regulation (1)	±0.2% max.
Load Regulation (2)	±0.2% max.
Over Voltage Protection trip Range ,% Vo nom	115-140%
Current Limit	105%-140% Nominal Output
Start up time	300ms typ.

GENERAL SPECIFICATIONS

Efficiency.	See Table
Isolation Voltage	Input/Output..... 3000VAC min. Input/Case.....2500VAC min. Output/Case.....500VAC min.
Isolation Resistance	10 ⁸ ohm min.
Switching Frequency	300KHz typ.
Operating Case Temperature Storage	-40°C to +100°C
Temperature	-55°C to +105°C
Thermal Shutdown, Case Temp.	105°C Typ.
Humidity	95% RH max. Non condensing
MTBF	MIL-HDBK-217F, GB,25°C, Full Load 5V :470Khrs typ., 12V:590Khrs typ., Others:760Khrs typ.
Dimensions	2.28 × 2.40 × 0.52 inches (57.9 × 61.0 × 13.2 mm)
Case Material	Aluminum Baseplate with Plastic Case
Weight	90g

NOTE

1. Measured from high line to low line.
2. Measured from full load to zero load.
3. Output ripple and noise measured with 10µF tantalum capacitor and 1µF ceramic capacitor across output.
(5V: 47µF polymer tantalum capacitor and 1µF ceramic capacitor across output).
(48V: 10µF aluminum capacitor and 1µF ceramic capacitor across output).
4. Logic compatibility.....open collector refer to -Vin
Module On.....>3.5VDC to 75VDC or open circuit
Module On.....0 to <1.2Vdc
5. Suffix "N" to the model number with negative logic remote on/off
Module On.....0 to <1.2Vdc
Module On.....>3.5VDC to 75VDC or open circuit

CHB350 SERIES

231-350 WATT

Features

- ◆ 231W-350W Isolated Output
- ◆ Efficiency to 92.5%
- ◆ Fixed Switching Frequency
- ◆ Input Under Voltage Protection
- ◆ Over Temperature Protection
- ◆ Over Voltage/Current Protection
- ◆ Remote On/Off
- ◆ Industry Standard Half-Brick Package
- ◆ Fully Isolated 1500VDC
- ◆ UL60950-1 Approval
- ◆ High Power Density 123W/in³



Mechanical Dimensions

All Dimensions in Inches (mm)
 Tolerance Inches: X.XX=±0.02, X.XXX=±0.010
 Millimeters: X.X=±0.5, X.XX=±0.25

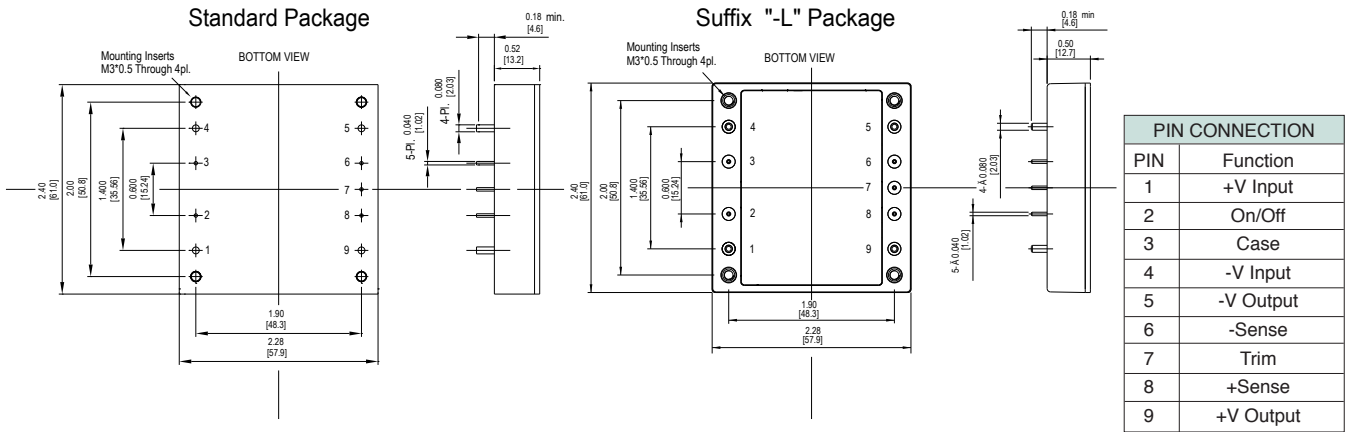

PIN CONNECTION	
PIN	Function
1	+V Input
2	On/Off
3	Case
4	-V Input
5	-V Output
6	-Sense
7	Trim
8	+Sense
9	+V Output

MODEL NUMBER	INPUT VOLTAGE	OUTPUT VOLTAGE	OUTPUT CURRENT		INPUT CURRENT		% EFF.	CAPACITOR LOAD MAX.
			MIN.	MAX.	NO LOAD	FULL LOAD		
CHB350-24S3V3□-X	18-36 VDC	3.3 VDC	0 mA	70 A	140 mA	10.94 A	88	10000µF
CHB350-24S05□-X	18-36 VDC	5 VDC	0 mA	70 A	260 mA	16.39 A	89	10000µF
CHB350-24S12□-X	18-36 VDC	12 VDC	0 mA	29.2 A	250 mA	16.13 A	90.5	10000µF
CHB350-24S24□-X	18-36 VDC	24 VDC	0 mA	14.6 A	60 mA	16.40 A	89	10000µF
CHB350-24S28□-X	18-36 VDC	28 VDC	0 mA	12.5 A	60 mA	16.11 A	90.5	7000µF
CHB350-24S48□-X	18-36 VDC	48 VDC	0 mA	7.3 A	60 mA	16.22 A	90	2200µF
CHB350-48S3V3□-X	36-75 VDC	3.3 VDC	0 mA	70 A	90 mA	5.41 A	89	10000µF
CHB350-48S05□-X	36-75 VDC	5 VDC	0 mA	70 A	130 mA	8.01 A	91	10000µF
CHB350-48S12□-X	36-75 VDC	12 VDC	0 mA	29.2 A	100 mA	7.89 A	92.5	10000µF
CHB350-48S24□-X	36-75 VDC	24 VDC	0 mA	14.6 A	60 mA	7.98 A	91.5	10000µF
CHB350-48S28□-X	36-75 VDC	28 VDC	0 mA	12.5 A	60 mA	7.93 A	92	7000µF
CHB350-48S48□-X	36-75 VDC	48 VDC	0 mA	7.3 A	60 mA	7.93 A	92	2200µF

NOTE:

1. □= N or None, X can be L, I, C, IC
2. Nominal Input Voltage 24, 48VDC
3. The output terminal of 28Vout and 48Vout models required a minimum capacitor 100uF to maintain specified regulation.

Remote On/Off Control

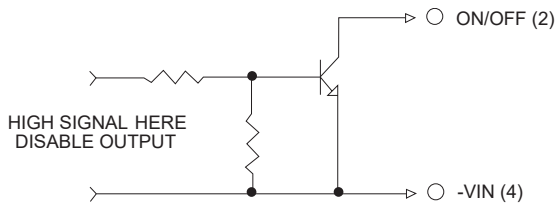

External Output Trim

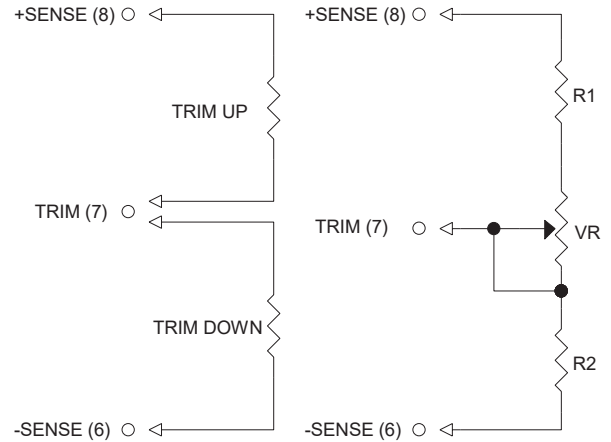

Specifications

All Specifications Typical At Nominal Line, Full Load, and 25°C Unless Otherwise Noted

INPUT SPECIFICATIONS

Input Voltage Range	24V 18-36V	48V 36-75V
Input Surge Voltage (100ms max.)	24V 50Vdc max.	48V 100Vdc max.
Under Voltage Lockout	24Vin	power up 17V power down 16V
	48Vin	power up 35V power down 33V
Positive Logic Remote On/Off		See note 4
Logic Compatibility		Open Collector ref to -Input
Module on		>3.5Vdc to 75Vdc or Open Circuit
Module off		0 to < 1.2Vdc
Input Filter		Pi Type

OUTPUT SPECIFICATIONS

Voltage Accuracy	±1.0% max.
Transient Response: 25% Step Load Change	< 500µs
External Trim Adj. Range (note 6)	±10%
Ripple & Noise, 20MHz BW	
3.3V & 5V	40mV RMS max., 100mV pk-pk max.
12V	60mV RMS max., 120mV pk-pk max.
24V & 28V	100mV RMS max., 280mV pk-pk max.
48V	150mV RMS max., 480mV pk-pk max.
Temperature Coefficient	±0.03%/°C
Short Circuit Protection	Continuous
Line Regulation (note 1)	±0.2% max.
Load Regulation (note 2)	±0.2% max.
Over Voltage Protection Trip Range, % Vo nom.	115-140%
Current Limit	105%-140% Nominal Output
Start up time	175ms typ.

GENERAL SPECIFICATIONS

Efficiency	See Table
Isolation Voltage	Input/Output 1500VDC min. Input/Case 1500VDC min. Output/Case 1500VDC min. 10 ⁷ ohm min.
Isolation Resistance	2000pF typ.
Isolation Capacitance	3V3 & 5V 300KHz typ. 12V & 24V & 28V & 48V 330KHz typ.
Switching Frequency	
Operating Case Temperature	-40°C to 100°C
Storage Temperature	-55°C to +105°C
Thermal Shutdown Case Temp	110°C typ.
Humidity	95% RH max. Non condensing
MTBF..... MIL-STD-217F, GB, 25°C, Full Load	700Khrs typ.
Dimensions Standard	2.28 x 2.40 x 0.52 inches (57.9 x 61.0 x 13.2 mm)
	2.28 x 2.40 x 0.50 inches (57.9 x 61.0 x 12.7mm)
	Suffix "-IL" (note 6)
Case Material	Aluminum Baseplate with Plastic Case
Weight	114 g

NOTE

1. Measured from high line to low line.
2. Measured from full load to zero load.
3. Output ripple and noise measured with 10µF tantalum (for 48Vout with 10µF aluminum) and 1µF ceramic capacitor across output.
4. Suffix "N" to the model number with negative logic remote On/Off
Module On 0 to < 1.2VDC
Module Off >3.5VDC to 75VDC or open circuit
5. Suffix "-C" to the model number with clear mounting Insert. (3.2mm DIA)
6. Suffix "-I" to the model number with thin input pin models (pin1 and pin4 = 1.0mm).
7. Trim-up.....connect a resistor between the trim pin and +Sense
Trim-down.....connect a resistor between the trim pin and -Sense
8. The input terminal recommend to parallel with 220µF for 48Vin and 470µF for 24Vin ESR< 0.7Ω to reduce the input ripple voltage.

CFB200 SERIES

100-200 WATT

Features

- ◆ 100W-200W Isolated Output
- ◆ Efficiency to 90%
- ◆ 2 : 1 Input Range
- ◆ 350KHz Switching Frequency
- ◆ Regulated Outputs
- ◆ Continuous Short Circuit Protection
- ◆ Industry Standard Full-Brick Package
- ◆ UL60950-1 and IEC60950-1 Approval



Mechanical Dimensions

NOTE: Pin Size is 0.02" Inch (0.5mm) DIA
 All Dimensions in Inches (mm)
 Tolerance Inches: X.XX=±0.02, X.XXX=±0.010
 Millimeters: X.X=±0.5, X.XX=±0.25

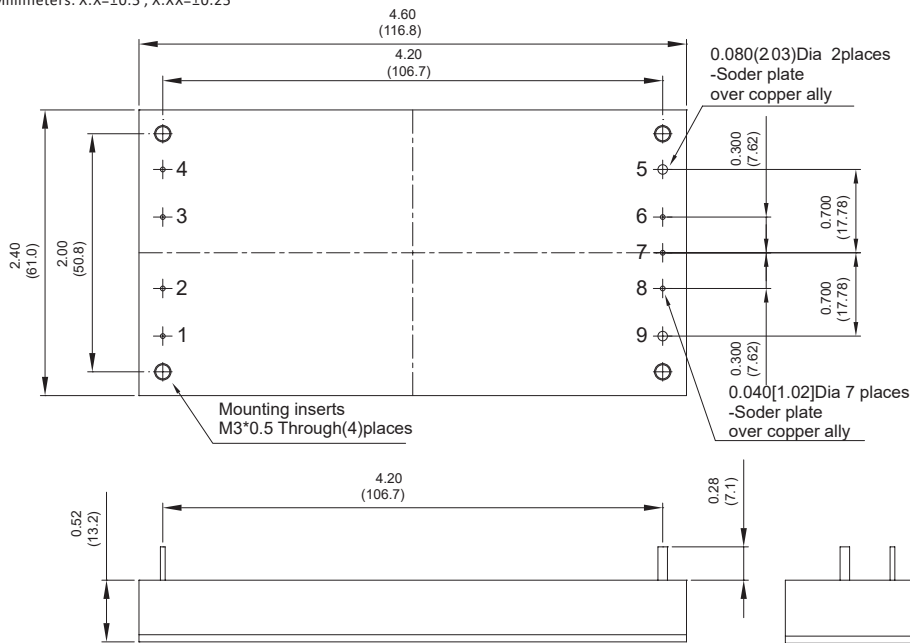

PIN	Function
1	+V Input
2	On/Off
3	NC
4	-V Input
5	-V Output
6	-Sense
7	Trim
8	+Sense
9	+V Output

MODEL NUMBER	INPUT VOLTAGE	OUTPUT VOLTAGE	OUTPUT CURRENT	INPUT CURRENT		% EFF.	CASE
				NO LOAD	FULL LOAD		
CFB200-48S25	36-75 VDC	2.5 VDC	40 A	25 mA	2.8 A	74	FB
CFB200-48S33	36-75 VDC	3.3 VDC	40 A	25 mA	3.5 A	79	FB
CFB200-48S05	36-75 VDC	5 VDC	40 A	25 mA	5 A	83	FB
CFB200-48S12	36-75 VDC	12 VDC	17 A	25 mA	5 A	85	FB
CFB200-48S15	36-75 VDC	15 VDC	13.3 A	25 mA	5 A	85	FB
CFB200-48S24	36-75 VDC	24 VDC	8.33 A	25 mA	5 A	85	FB
CFB200-48S28	36-75 VDC	28 VDC	7.14 A	25 mA	4.7 A	89	FB
CFB200-48S48	36-75 VDC	48 VDC	4.2 A	25 mA	4.7 A	90	FB

NOTE: 1. Nominal Input Voltage 48VDC

Remote On/Off Control

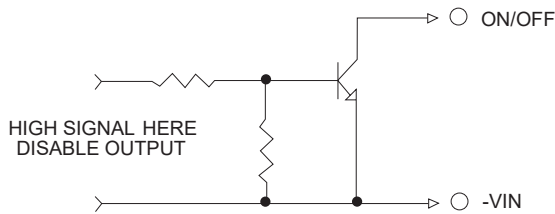

External Output Trim

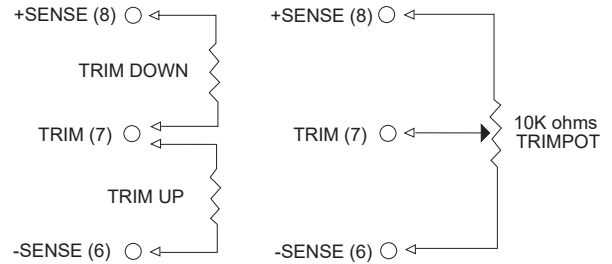

Specifications

All Specifications Typical At Nominal Line, Full Load, and 25°C Unless Otherwise Noted

INPUT SPECIFICATIONS

Input Voltage Range	48V	36-75V
Undervoltage lockout	48Vin power up	34V
	power down	32.5V
Positive Logic Remote On/Off	See note 3, 4	
Input Filter	Pi Type	

OUTPUT SPECIFICATIONS

Voltage Accuracy	±1.0% max.
Transient Response 25% Step Load Change	< 500µs
External Trim Adj. Range	±10%
Ripple and Noise, 20MHz BW, 2.5V & 3.3V & 5V	40mV RMS. max. 100mV p-p max.
12V & 15V	60mV RMS. max. 150mV p-p max.
24V & 28V & 48V	100mV/150mV/200mV RMS. max. 240mV/280mV/480mV p-p max.
Temperature Coefficient	±0.03%/°C
Short Circuit Protection	Continuous
Line Regulation (note 1)	±0.2% max.
Load Regulation (note 2)	±0.2% max.
Over Voltage Protection trip Range, % Vo nom	115-140%
Current Limit	110%-150% Nominal Output

GENERAL SPECIFICATIONS

Efficiency	See Table
Isolation Voltage	Input/Output 1500 VDC min. Input/Case 1500 VDC min. Output/Case 1500 VDC min.
Isolation Resistance	10 ⁷ ohms min.
Switching Frequency	350KHz typ.
Operating Case Temperature	-40°C to 100°C
Storage Temperature	-40°C to +105°C
Thermal Shutdown, Case Temp.	100°C Typ.
Dimensions	4.60 × 2.40 × 0.52 inches (116.8 × 61.0 × 13.2 mm)
Case Material	Aluminum Baseplate with Plastic Case
Weight	193 g

NOTE

1. Measured from high line to low line.
2. Measured from full load to zero load.
3. Logic compatibility open collector Ref. to -Input
Module On Open Circuit
Module Off <0.8VDC
4. Suffix "N" to the model number with negative logic remote On/Off.

CFB400W SERIES

400 WATT, 4:1 INPUT RANGE

Features

- ◆ 400W Isolated Output
- ◆ Efficiency to 90%
- ◆ Fixed Switching Frequency
- ◆ Input Under Voltage Protection
- ◆ Over Temperature Protection
- ◆ Over Voltage/Current Protection
- ◆ Remote On/Off
- ◆ Full-Brick Size Meets Industry Standard
- ◆ Fully Isolated 1500VDC
- ◆ Without Tantalum Capacitor Inside
- ◆ UL60950-1 Approval



Mechanical Dimensions

All Dimensions in Inches (mm)
 Tolerance Inches: X.XX=±0.02, X.XXX=±0.010
 Millimeters: X.X=±0.5, X.XX=±0.25

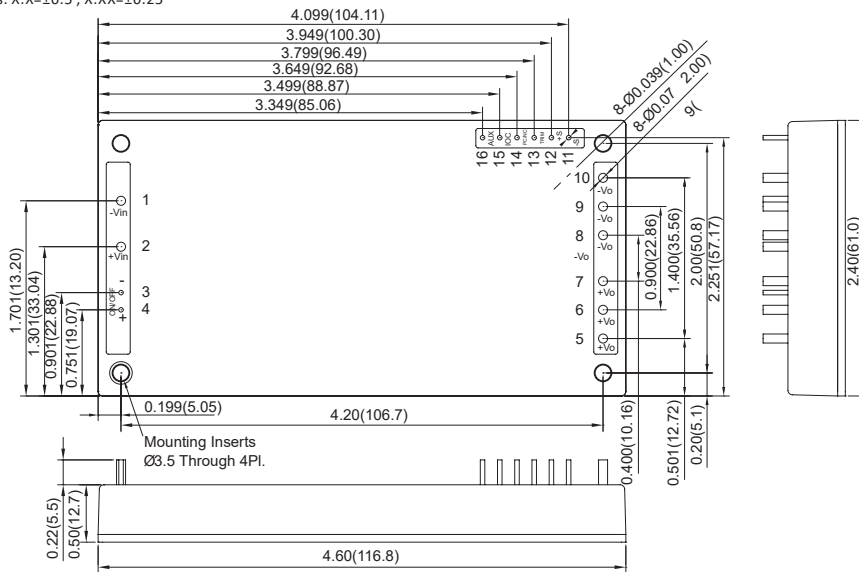

PIN CONNECTION	
PIN	Function
1	-V Input
2	+V Input
3	-On/Off
4	+On/Off
5-7	+V Output
8-10	-V Output
11	-Sense
12	+Sense
13	Trim
14	PC/NC
15	IOG
16	AUX

MODEL NUMBER	INPUT VOLTAGE	OUTPUT VOLTAGE	OUTPUT CURRENT		INPUT CURRENT		% EFF.		CAPACITOR LOAD MAX. (4, 5, 6)
			MIN.	MAX.	NO LOAD	FULL LOAD	(2)	(3)	
CFB400W-24S05	9-36 VDC	5 VDC	0 mA	80 A	600 mA	19.05 A	86.5	87.5	10000µF
CFB400W-24S12	9-36 VDC	12 VDC	0 mA	33.3 A	120 mA	19.36 A	85	86	10000µF
CFB400W-24S24	9-36 VDC	24 VDC	0 mA	16.7 A	120 mA	19.19 A	88	87	4700µF
CFB400W-24S28	9-36 VDC	28 VDC	0 mA	14.3 A	120 mA	19.18 A	86.5	87	4700µF
CFB400W-24S48	9-36 VDC	48 VDC	0 mA	8.3 A	120 mA	19.19 A	85.5	86.5	2200µF
CFB400W-48S05	18-75 VDC	5 VDC	0 mA	80 A	300 mA	9.36 A	88.5	89	10000µF
CFB400W-48S12	18-75 VDC	12 VDC	0 mA	33.3 A	60 mA	9.41 A	88.5	88.5	10000µF
CFB400W-48S24	18-75 VDC	24 VDC	0 mA	16.7 A	60 mA	9.28 A	90	90	4700µF
CFB400W-48S28	18-75 VDC	28 VDC	0 mA	14.3 A	60 mA	9.27 A	90.5	90	4700µF
CFB400W-48S48	18-75 VDC	48 VDC	0 mA	8.3 A	60 mA	9.27 A	88	89.5	2200µF

NOTE:

1. Nominal Input Voltage 24, 48 VDC.
2. Measured at 12VDC for 24Vin, 24VDC for 48Vin.
3. Measured at Nominal Input Voltage.
4. The output terminal of 12V, 24V, 28V Vout models required a minimum capacitor 330uF to maintain specified regulation.
5. The output terminal of 5Vout models required a minimum capacitor 680uF to maintain specified regulation.
6. The output terminal of 48Vout models required a minimum capacitor 100uF to maintain specified regulation.

External Output Trim

Fig.1 The schematic of output voltage adjusted by using external resistor and/or variable resistor.

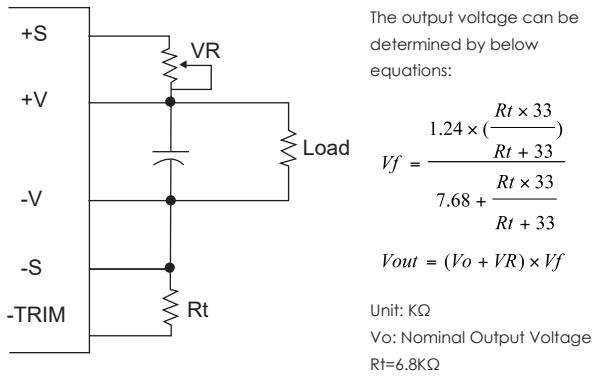
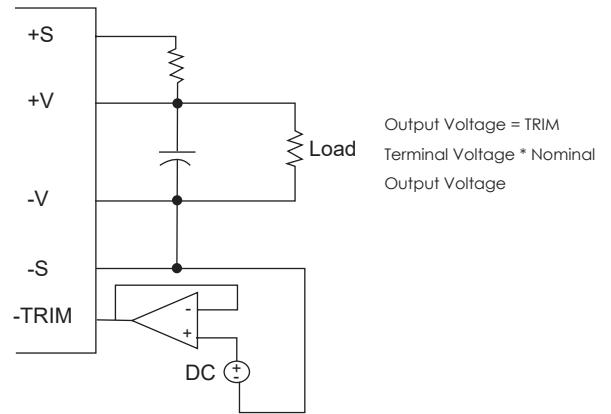

Fig.2 The schematic of output voltage adjusted by using external DC voltage.



Specifications

All Specifications Typical At Nominal Line, Full Load, and 25°C Unless Otherwise Noted

INPUT SPECIFICATIONS

Input Voltage Range	24V	9-36V
Under Voltage Lockout	24Vin	18-75V power up
	48Vin	8.5V power up
Input Over Voltage Protection	24Vin	17V power up
	48Vin	15V power down
Opto Isolated Remote On/Off	24Vin	Turn off 42V
	48Vin	Turn on 40V
Input Filter	24Vin	Turn off 83V
	48Vin	Turn on 80V
Input Filter		See note 6
		LC Type

OUTPUT SPECIFICATIONS

Voltage Accuracy	±1.0% max.
Transient Response: 25% Step Load Change	< 500µs
External Trim Adj. Range	80-110%
Load share Accuracy	±10% at 50% to 100% Full Load
Auxiliary Output Voltage/Current	10±3Vdc/20mA max.
Ripple & Noise, 20MHz BW (note 3)	
5V	40mV RMS max., 100mV pk-pk max.
12V	60mV RMS max., 120mV pk-pk max.
24V	100mV RMS max., 240mV pk-pk max.
28V	100mV RMS max., 280mV pk-pk max.
48V	120mV RMS max., 480mV pk-pk max.
Temperature Coefficient	±0.03%/°C
Short Circuit Protection	Continuous
Line Regulation (note 1)	±0.2% max.
Load Regulation (note 2)	±0.5% max.
Over Voltage Protection Trip Range, % Vo nom.	115-140%
Current Limit	110% -150% Nominal Output
Start up time	120ms typ.

GENERAL SPECIFICATIONS

Efficiency	See Table
Isolation Voltage	Input/Output 1500VDC min. Input/Case 1500VDC min. Output/Case 1500VDC min.
Isolation Resistance	10 ⁷ ohm min.
Isolation Capacitance	4000pF typ.
Switching Frequency	230KHz typ.
Operating Case Temperature	-40°C to 100°C
Storage Temperature	-55°C to +110°C
Thermal Shutdown Case Temp.	110°C typ.
Humidity	95% RH max. Non condensing
MTBF MIL-HDBK-217F, GB, 25°C, Full Load	340Khrs typ.
Dimensions	4.60 × 2.40 × 0.50 inches (116.8 × 61.0 × 12.7 mm)
Case Material	Aluminum Baseplate with Plastic Case
Weight	220 g

NOTE

1. Measured from high line to low line.
2. Measured from full load to zero load.
3. Output ripple and noise measured with 10µF tantalum and 1µF ceramic capacitor across output.
4. The output adjustment circuit and trim equations show as figure1 and figure2.
5. An external input capacitor 1000µF for 24Vin or 330µF for 48Vin models are recommended to reduce input ripple voltage.
6. Standard model is negative logic, suffix "P" to the model number with positive logic. (refer application note)
7. If the remote sense feature is not to be used, the +sense pin should be connected to the +Vout pin and the -sense pin should be connected to the -Vout pin. (refer application note)

CFB600 SERIES

600-700 WATT, 2:1 INPUT RANGE

Features

- ◆ 600W-700W Isolated Output
- ◆ Efficiency to 92%
- ◆ Fixed Switching Frequency
- ◆ Input Under-Voltage Protection
- ◆ Over Temperature Protection
- ◆ Over Voltage/Current Protection
- ◆ Remote On/Off
- ◆ Industry Full-Brick Package
- ◆ Fully Isolated 1500VDC
- ◆ UL60950-1 Approval



Mechanical Dimensions

All Dimensions in Inches (mm)
 Tolerance Inches: X.XX±0.02, X.XXX±0.010
 Millimeters: X.X±0.5, X.XX±0.25

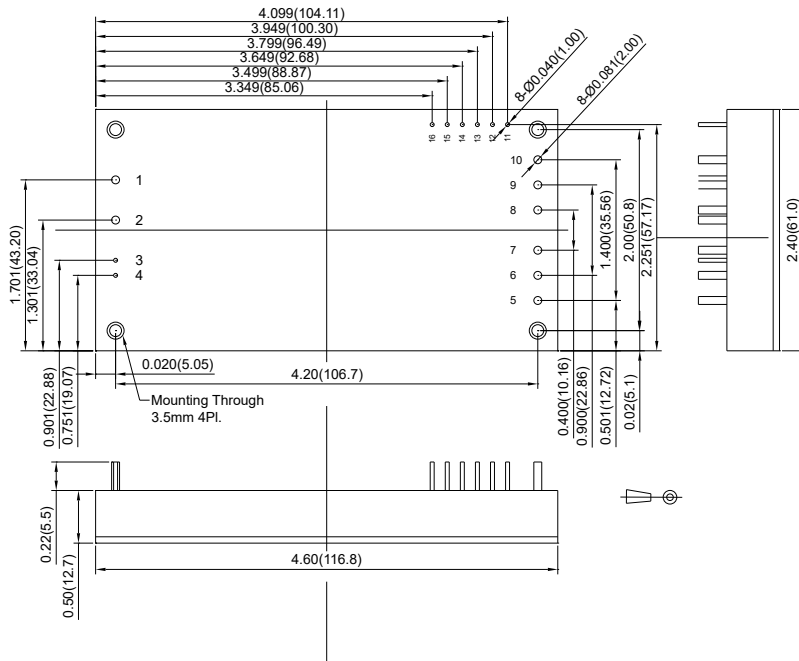

PIN CONNECTION	
PIN	Function
1	-V Input
2	+V Input
3	-On/Off
4	+On/Off
5-7	+V Output
8-10	-V Output
11	-Sense
12	+Sense
13	Trim
14	PC/NC
15	IOG
16	AUX

MODEL NUMBER	INPUT VOLTAGE	OUTPUT VOLTAGE	OUTPUT CURRENT		INPUT CURRENT		% EFF.	CAPACITOR LOAD MAX.
			MIN.	MAX.	NO LOAD	FULL LOAD		
CFB600-24S12	18-36 VDC	12 VDC	0 mA	50 A	150 mA	28.09 A	88	10000µF ⁽²⁾
CFB600-24S24	18-36 VDC	24 VDC	0 mA	25 A	150 mA	27.78 A	89	5000µF ⁽²⁾
CFB600-24S28	18-36 VDC	28 VDC	0 mA	21.5 A	150 mA	27.87 A	90	5000µF ⁽²⁾
CFB600-24S32	18-36 VDC	32 VDC	0 mA	19 A	150 mA	27.84 A	91	5000µF ⁽²⁾
CFB600-24S48	18-36 VDC	48 VDC	0 mA	12.5 A	200 mA	27.47 A	91	5000µF ⁽²⁾
CFB600-48S12	36-75 VDC	12 VDC	0 mA	50 A	90 mA	13.89 A	90	10000µF ⁽²⁾
CFB600-48S24	36-75 VDC	24 VDC	0 mA	25 A	100 mA	13.59 A	92	5000µF ⁽²⁾
CFB700-48S28	36-75 VDC	28 VDC	0 mA	25 A	105 mA	16.03 A	91	5000µF ⁽²⁾
CFB600-48S32	36-75 VDC	32 VDC	0 mA	19 A	90 mA	13.77 A	92	5000µF ⁽²⁾
CFB600-48S48	36-75 VDC	48 VDC	0 mA	12.5 A	130 mA	13.59 A	92	5000µF ⁽²⁾

NOTE:

1. Nominal Input Voltage 24, 48 VDC

2. The output terminal of all models required a minimum capacitor 470µF to maintain specified regulation.

External Output Trim

Fig.1 The schematic of output voltage adjusted by using external resistor and/or variable resistor.

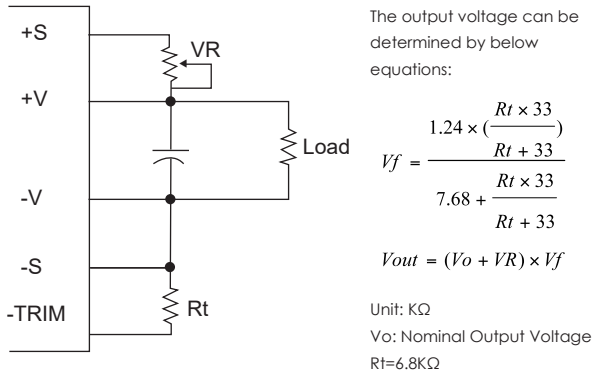
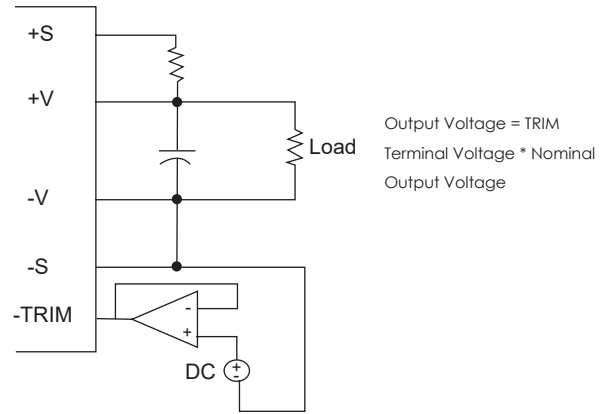

Fig.2 The schematic of output voltage adjusted by using external DC voltage.



Specifications

All Specifications Typical At Nominal Line, Full Load, and 25°C Unless Otherwise Noted

INPUT SPECIFICATIONS

Input Voltage Range	24V 18-36V	48V 36-75V
Input Surge Voltage (100ms max.)	24V 50Vdc max.	48V 100Vdc max.
Under voltage lockout	24Vin	power up 17V
	48Vin	power down 16V
Input over voltage protection	24Vin	power up 35V
	48Vin	power down 33V
Opto isolated Remote On/Off		Turn off 40V
Input Filter(note 7)		Turn on 38V
		Turn off 80V
		Turn on 77V
		See note 6
		PI Type

OUTPUT SPECIFICATIONS

Voltage Accuracy	±1.0% max.
Transient Response:25% Step Load Change	< 500 μ s
External Trim Adj. Range	60-110%
Load share Accuracy	±10% at 50% to 100% Full Load
Auxiliary output voltage/current	10±3Vdc/20mA max.
Ripple & Noise, 20MHz BW	
12V	60mV RMS max., 120mV pk-pk max.
24V	100mV RMS max., 240mV pk-pk max.
28V	100mV RMS max., 280mV pk-pk max.
32V	120mV RMS max., 320mV pk-pk max.
48V	200mV RMS max., 480mV pk-pk max
Temperature Coefficient	±0.03%/°C
Short Circuit Protection	Continuous
Line Regulation (note 1)	±0.2% max.
Load Regulation (note 2)	±0.5% max.
Over Voltage Protection trip Range,% Vo nom.	115-140%
Current Limit	110% -150% Nominal Output
Start up time	160ms typ.

GENERAL SPECIFICATIONS

Efficiency	See Table
Isolation Voltage	Input/Output 1500VDC min.
	Input/Case 1500VDC min.
	Output/Case 1500VDC min.
Isolation Resistance	10 ⁷ ohm min.
Isolation Capacitance	4000pF typ.
Switching Frequency	48S12 & 48S28 & 48S32...300KHz typ.
	Others 250KHz typ.
Operating Case Temperature	-40°C to 100°C
Storage Temperature	-55°C to +105°C
Thermal Shutdown, Case Temp.	110°C typ.
Humidity	95% RH max. Non condensing
MTBF MIL-STD-217F, GB, 25°C, Full Load	450Khrs typ.
Dimensions	4.60 x 2.40 x 0.50 inches (116.8 x 61.0 x 12.7 mm)
Case Material	Aluminum Baseplate with Plastic Case
Weight	220 g

NOTE

1. Measured from high line to low line.
2. Measured from full load to zero load.
3. Output ripple and noise measured with 10 μ F tantalum and 1 μ F ceramic capacitor across output.
4. The output adjustment circuit and trim equations show as figure1 and figure2.
5. An external input capacitor 220 μ F for all models are recommended to reduce input ripple voltage.
6. Standard model is negative logic, suffix "P" to the model number with positive logic. (refer application note)
7. If the remote sense feature is not to be used, the +sense pin should be connected to the +Vout pin and the -sense pin should be connected to the -Vout pin. (refer application note Item 6.9)

CFB600W-110S SERIES

600 WATT DC-DC CONVERTERS

Features

- ◆ 600W Isolated Output
- ◆ Efficiency to 88%
- ◆ Regulated Outputs
- ◆ Isolated Remote On/Off
- ◆ Over Temperature Protection
- ◆ Over Voltage/Current Protection
- ◆ Continuous Short Circuit Protection
- ◆ Full-Brick Size Meet Industry Standard
- ◆ Meet EN50155 with External Circuits
- ◆ Shock & Vibration Meet EN50155 (EN61373)
- ◆ Meet UL60950-1 2nd (Basic Insulation)
- ◆ Fire & Smoke Meet EN45545-2



Mechanical Dimensions

All Dimensions in Inches[mm]
 Tolerance Inches:x.xx±0.02, x.xxx±0.01 ±0.004
 Millimeters:x.x±0.5, x.xx±0.25 ±0.1

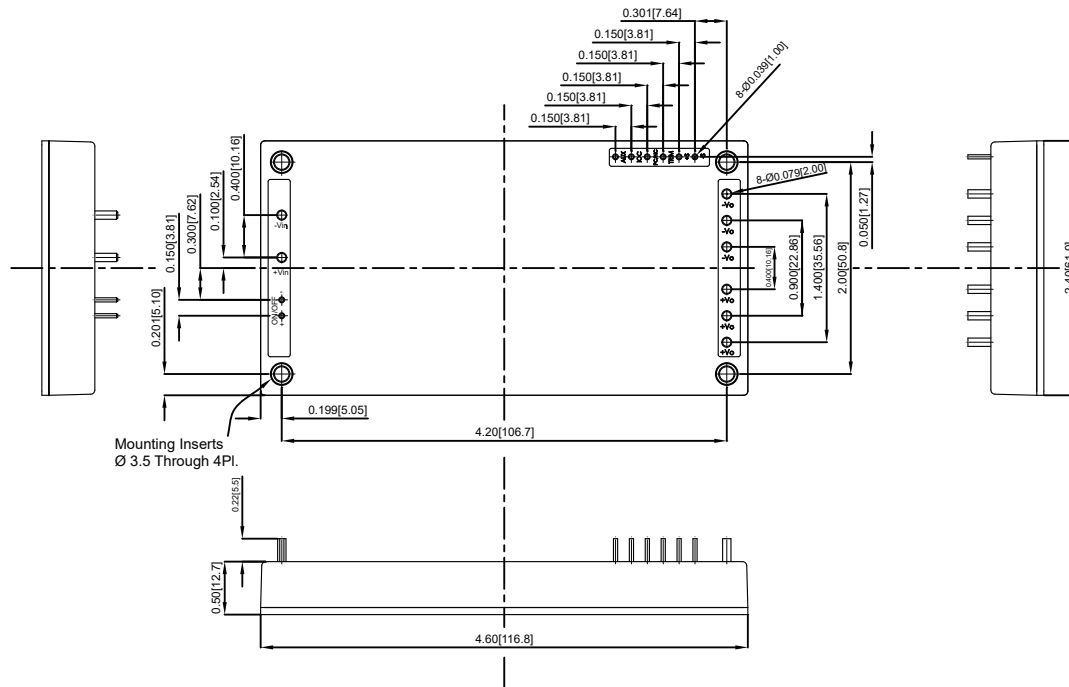

PIN CONNECTION	
PIN NUMBER	CONNECTION
1	-V Input
2	+V Input
3	-On/Off
4	+On/Off
5~7	+V Output
8~10	-V Output
11	-Sense
12	+Sense
13	TRIM
14	PC
15	IOC
16	AUX

MODEL NUMBER	INPUT VOLTAGE	OUTPUT VOLTAGE	OUTPUT CURRENT		INPUT CURRENT		% EFF. (3)	CAPACITOR LOAD MAX.
			MIN.	MAX.	NO LOAD	FULL LOAD		
CFB600W-110S12	43-160 VDC	12 VDC	0 mA	50 A	25 mA	6.3 A	87	10000µF
CFB600W-110S24	43-160 VDC	24 VDC	0 mA	25 A	25 mA	6.2 A	88	10000µF
CFB600W-110S28	43-160 VDC	28 VDC	0 mA	21.4 A	25 mA	6.2 A	88	10000µF
CFB600W-110S48	43-160 VDC	48 VDC	0 mA	12.5 A	25 mA	6.2 A	88	10000µF

NOTE:
 1. Nominal Input Voltage 110 VDC.
 2. The Output Terminal Required a Minimum Capacitor 470uF to Maintain Specified Regulation.
 3. Measure at Nominal Input Voltage.

Specifications

All Specifications Typical At Nominal Line, Full Load, and 25°C Unless Otherwise Noted

INPUT SPECIFICATIONS

Input Voltage Range	110V 43-160V
Input Surge Voltage (100ms max.)	180Vdc max.
Under voltage lockout	power up 42V power down 40V
Opto Isolated Remote On/Off	See note 8
Input Filter	PI Type

OUTPUT SPECIFICATIONS

Voltage Accuracy:	±1.0% max.
Transient Response: 25% Step Load Change	<500µs
External Trim Adj. Range	60%, +110%
Ripple & Noise, 20MHz BW (see note 3)	
12V	60mV RMS, 120mV pk-pk max.
24V	100mV RMS, 240mV pk-pk max.
28V	100mV RMS, 280mV pk-pk max.
48V	200mV RMS, 480mV pk-pk max.
Temperature Coefficient	±0.03%/°C
Short Circuit Protection	Continuous
Line Regulation (note 1)	±0.2% max.
Load Regulation (note 2)	±0.5% max.
Over Voltage Protection trip Range, % Vo nom.	115-140%
Current Limit	105%-140% Nominal Output
Auxiliary Output Voltage/Current	10±3Vdc/20mA max.
Start up time	160ms typ.

GENERAL SPECIFICATIONS

Efficiency	See Table
Isolation Voltage	Input/Output 2250VDC min. Input/Case 2250VDC min. Output/Case 1500VDC min.
Isolation Resistance	10 ⁷ ohm min.
Isolation Capacitance	4000pF typ
Switching Frequency	250KHz typ.
Operating Case Temperature	-40°C to 100°C
Storage Temperature	-55°C to +105°C
Thermal Shutdown, Case Temp.	110°C typ.
Humidity	95% RH max. Non condensing
Operating Altitude	2000m
MTBF ... MIL-STD-217F, GB, 25°C, Full Load	450Khrs typ.
Safety	UL60950-1 2 nd (Basic insulation)
EMC (note 5)	EN50155(EN50121-3-2) with External Filter
Shock/Vibration	EN50155 (EN61373)
Environmental	EN50155 (EN60068-2-1)
Dimensions	4.60×2.40×0.50 inches (116.8×61.0×12.7 mm)
Case Material	Aluminum Baseplate with Plastic Case
Weight	220 g

NOTE

1. Measured from high line to low line.
2. Measured from full load to zero load.
3. Output ripple and noise measured with 10uF tantalum capacitor and 1uF ceramic capacitor across output.(48Vo: 10uF aluminum capacitor and 1.0uF ceramic capacitors)
4. An external input capacitor 220uF for all models are recommended to reduce input ripple voltage.
5. For information about EN50155 and RIA12, refer to application note.
6. Trim-up: connect a resistor between trim pin and +sense.
Trim-down: connect a resistor between trim pin and -sense.
7. Suffix "-CO" to the model number with threaded mounting holes (M3x0.5).
8. Standard model is negative logic, suffix "P" to the model number with positive logic.
(refer application note)

CFB600-300S SERIES

600 WATT, INPUT RANGE 180-425 VDC

Features

- ◆ 600W Isolated Output
- ◆ Efficiency to 91%
- ◆ Fixed Switching Frequency
- ◆ Input Under-Voltage Protection
- ◆ Over Temperature Protection
- ◆ Over Voltage/Current Protection
- ◆ Remote On/Off
- ◆ Single Wire Parallel
- ◆ Industry Full-Brick Package
- ◆ UL 60950-1 Approval
- ◆ Fully Isolated 3000VAC



Mechanical Dimensions

All Dimensions in Inches (mm)

Tolerance Inches: X.XX=±0.02, X.XXX=±0.010
 Millimeters: X.X=±0.5, X.XX=±0.25

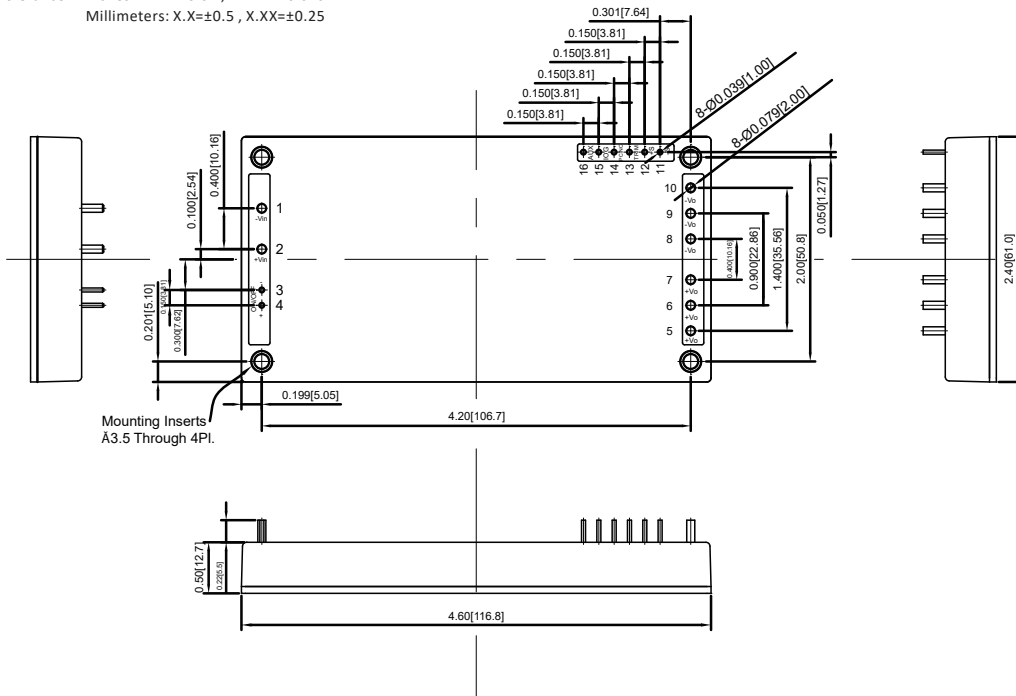

PIN CONNECTION	
PIN	Function
1	-V Input
2	+V Input
3	-On/Off
4	+On/Off
5-7	+V Output
8-10	-V Output
11	-Sense
12	+Sense
13	Trim
14	PC/NC
15	IOG
16	AUX

MODEL NUMBER	INPUT VOLTAGE	OUTPUT VOLTAGE	OUTPUT CURRENT		INPUT CURRENT		% EFF.	CAPACITOR LOAD MAX.
			MIN.	MAX.	NO LOAD	FULL LOAD		
CFB600-300S12	180-425 VDC	12 VDC	0 mA	50 A	10 mA	2.24 A	89.5	10000µF
CFB600-300S24	180-425 VDC	24 VDC	0 mA	25 A	10 mA	2.21 A	90.5	10000µF
CFB600-300S48	180-425 VDC	48 VDC	0 mA	12.5 A	10 mA	2.20 A	91	8000µF

NOTE:

1. Nominal Input Voltage 300 VDC.
2. The output terminal required a minimum capacitor 470uF to maintain specified regulation.
3. Measure at Nominal Input Voltage.

External Output Trim

Fig.1 The schematic of output voltage adjusted by using external resistor and/or variable resistor.

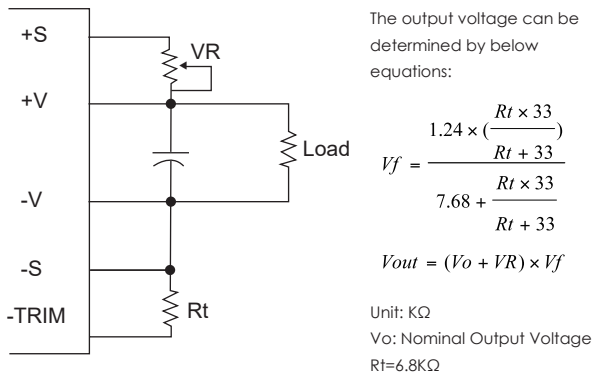
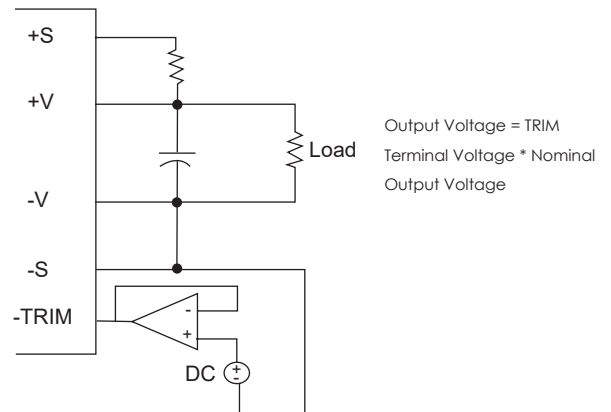

Fig.2 The schematic of output voltage adjusted by using external DC voltage.



Specifications

All Specifications Typical At Nominal Line, Full Load, and 25°C Unless Otherwise Noted

INPUT SPECIFICATIONS

Input Voltage Range	300V	180-425V
Input Over Voltage Protection	Module on	480V
	Module off	500V
Under Voltage Lockout	300V _{in} Power Up	170V
	Power Down	160V
Positive Logic Remote On/Off	See note 5 & 6	
Input Filter(note 7)	Capacitive	

OUTPUT SPECIFICATIONS

Voltage Accuracy	±1.0% max.
Transient Response:25% Step Load Change	< 500 μ s
External Trim Adj. Range (note 4)	60-110%
Load share Accuracy	±10% at 50% to 100%Full Load
Auxiliary Output Voltage/Current	10±3Vdc/20mA max.
Ripple & Noise, 20MHz BW (note 3)	
12V	75mV RMS max., 150mV pk-pk max.
24V	120mV RMS max., 240mV pk-pk max.
48V	200mV RMS max., 480mV pk-pk max.
Temperature Coefficient	±0.03%/°C
Short Circuit Protection	Continuous
Line Regulation (note 1)	±0.2% max.
Load Regulation (note 2)	±0.5% max.
Over Voltage Protection Trip Range, % Vo nom	115-140%
Current Limit	105% -125% Nominal Output
Start up time	40ms typ.

GENERAL SPECIFICATIONS

Efficiency	See Table
Isolation Voltage	Input/Output3000VAC min. Input/Case 2500VAC min. Output/Case500VAC min.
Isolation Resistance	10 ⁷ ohm min.
Switching Frequency	200KHz typ.
Operating Case Temperature Storage Temperature	-40°C to 100°C -55°C to +105°C
Thermal Shutdown, Case Temp.	105°C typ.
Humidity	95% RH max. Non condensing
MTBF MIL-STD-217F, GB, 25°C, Full Load	420Khrs typ.
Dimensions	4.60 × 2.40 × 0.50 inches (116.8 × 61.0 × 12.7 mm)
Case Material	Aluminum Baseplate with Plastic Case
Weight	230 g typ.

NOTE

1. Measured from high line to low line.
2. Measured from full load to zero load.
3. Output ripple and noise measured with min. capacitor 470 μ F and 1 μ F ceramic capacitor across output.
4. The output adjustment circuit and trim equations show as figure1 and figure2.
5. Logic compatibility open collector refer to -Vin
Module On >3.5VDC to 75VDC or open circuit
Module Off 0 to <1.2Vdc
6. Suffix "N" to the model number with negative logic remote On/Off
Module On 0 to <1.2Vdc
Module Off >3.5VDC to 75VDC or open circuit
7. An external input capacitor 330 μ F for all models are recommended to reduce input ripple voltage.

CFB750-300S SERIES

750 WATT 2:1 INPUT DC-DC CONVERTERS

Features

- ◆ 750W Isolated Output
- ◆ Efficiency to 90%
- ◆ Fixed Switching Frequency
- ◆ Input Under-Voltage Protection
- ◆ Over Temperature Protection
- ◆ Over Voltage/Current Protection
- ◆ Remote On/Off
- ◆ Industry Full-Brick Package
- ◆ Single Wire Parallel
- ◆ Meets UL 60950-1
- ◆ Fully Isolated 3000VAC



Mechanical Dimensions

All Dimensions in Inches[mm]
 Tolerance Inches: x.xx=±0.02, x.xxx=±0.01
 Millimeters: x.x=±0.5, x.xx=±0.25

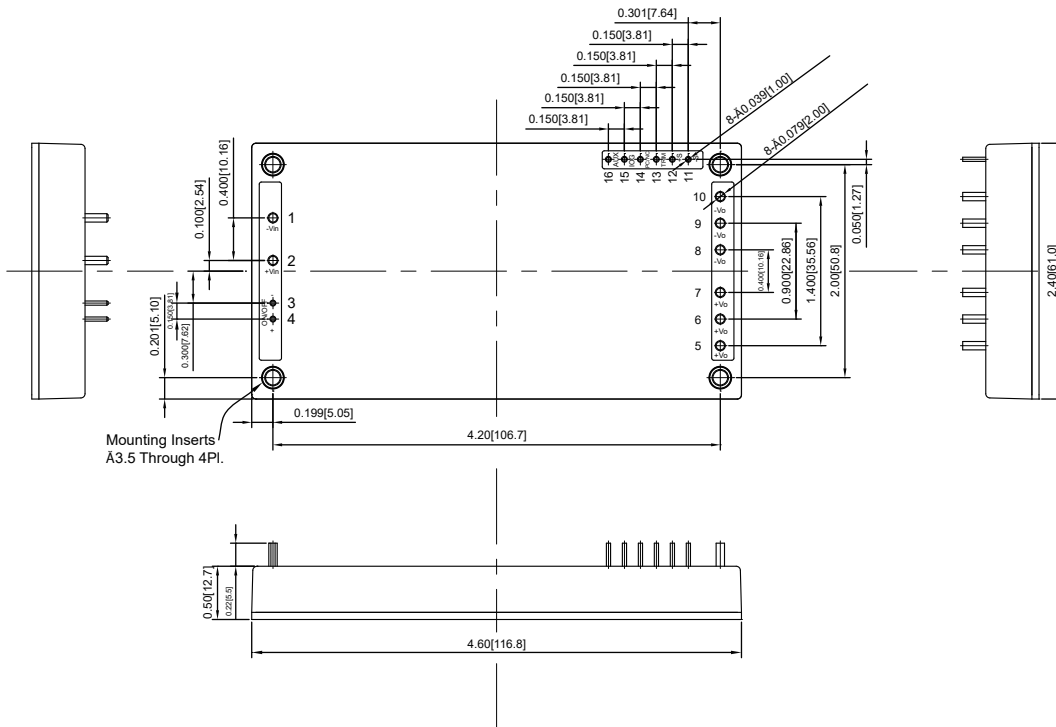

PIN CONNECTION	
PIN NUMBER	CONNECTION
1	-V Input
2	+V Input
3	-On/Off
4	+On/Off
5~7	+V Output
8~10	-V Output
11	-Sense
12	+Sense
13	TRIM
14	PC
15	IOG
16	AUX

MODEL NUMBER	INPUT VOLTAGE	OUTPUT VOLTAGE	OUTPUT CURRENT		INPUT CURRENT		% EFF.	CAPACITOR LOAD MAX.
			MIN.	MAX.	NO LOAD	FULL LOAD		
CFB750-300S12	200-425VDC	12 VDC	0 mA	62.5 A	10 mA	2.84 A	88	10000µF
CFB750-300S15	200-425VDC	15 VDC	0 mA	50 A	10 mA	2.84 A	88	10000µF
CFB750-300S24	200-425VDC	24 VDC	0 mA	31.2 A	10 mA	2.78 A	90	10000µF
CFB750-300S28	200-425VDC	28 VDC	0 mA	26.7 A	10 mA	2.78 A	90	10000µF
CFB750-300S36	200-425VDC	36 VDC	0 mA	20.8 A	10 mA	2.78 A	90	8000µF
CFB750-300S48	200-425VDC	48 VDC	0 mA	15.6 A	10 mA	2.78 A	90	8000µF

NOTE:
 1. Nominal input voltage 300 VDC
 2. The output terminal required a minimum capacitor 1000uF to maintain specified regulation.
 3. Measure at nominal input voltage

External Output Trim

Fig.1 The schematic of output voltage adjusted by using external resistor and/or variable resistor.

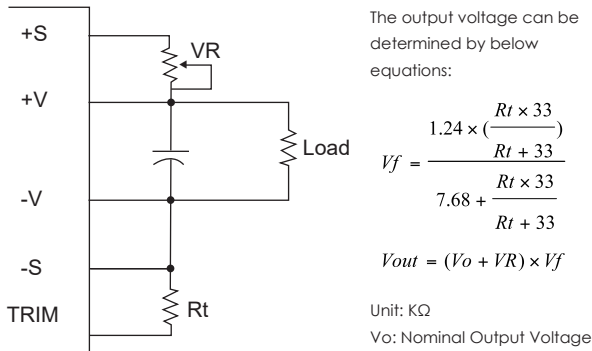
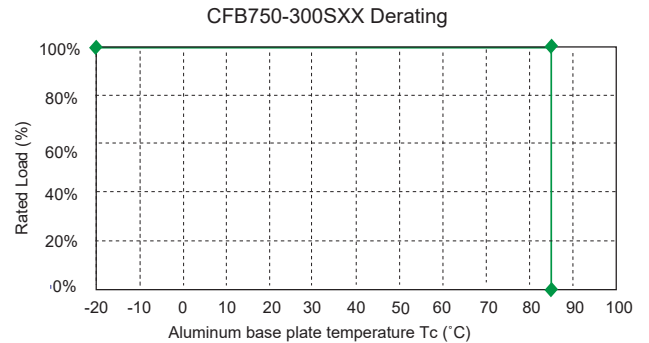
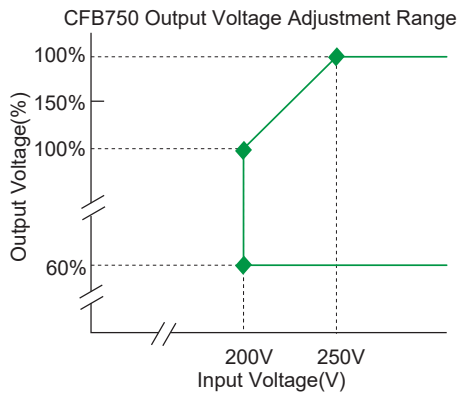
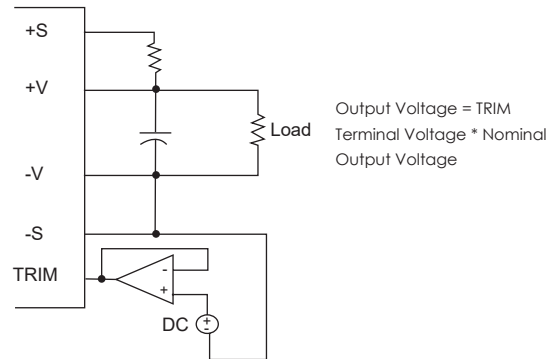

Fig.2 The schematic of output voltage adjusted by using external DC voltage.



Specifications

All Specifications Typical At Nominal Line, Full Load, and 25°C Unless Otherwise Noted

INPUT SPECIFICATIONS

Input Voltage Range	300V 200-425V
Input Over Voltage Protection	Module on480V Module off500V
Under voltage lockout	300Vin power up195V 300Vin power down180V
Positive Logic Remote On/Off (note5&6)	
Input Filter (note 7)	C Type

OUTPUT SPECIFICATIONS

Voltage Accuracy	±1.0% max.
Transient Response: 25% Step Load Change	<500 μ s
External Trim Adj. Range(note 4)	60%-110%
Ripple & Noise, 20MHz BW (see note 3)	
12V&15V	150mV RMS, 300mV pk-pk max.
24V&28V	300mV RMS, 600mV pk-pk max.
36V	300mV RMS, 650mV pk-pk max.
48V	350mV RMS, 750mV pk-pk max.
Temperature Coefficient	±0.03%/°C
Short Circuit Protection	Continuous
Line Regulation (note 1)	±0.2% max.
Load Regulation (note 2)	±0.5% max.
Over Voltage Protection trip Range, % Vo nom.	115-140%
Current Limit	105%-125% Nominal Output

GENERAL SPECIFICATIONS

Efficiency	See Table
Isolation Voltage	Input/Output 3000VAC min. Input/Case 2500VAC min. Output/Case 500VAC min.
Isolation Resistance	10 ⁷ ohm min.
Switching Frequency	200KHz typ.
Operating Case Temperature	-40°C to 85°C
Storage Temperature	-55°C to +105°C
Thermal Shutdown, Case Temp.	95°C typ.
Humidity	95% RH max. Non condensing
MTBF ... MIL-STD-217F, GB	370Khrs typ.
Dimensions	4.60x2.40x0.50 inches (116.8x61.0x12.7 mm)
Case Material	Aluminum Baseplate with Plastic Case
Weight	230g typ.

NOTE

- Measured from high line to low line.
- Measured from full load to zero load.
- Output ripple and noise measured with 1 μ F ceramic capacitor and 1000 μ F aluminum capacitor across output.
- The output adjustment circuit and trim equations show as Figure1 and Figure2.
- Logic compatibility.....open collector refer to -Vin
Module on>3.5Vdc to 75Vdc or Open Circuit
Module off0 to <1.2Vdc
- Suffix "N" to the model number with negative logic remote on/off
Module on0 to <1.2Vdc
Module off>3.5Vdc to 75Vdc or Open Circuit

CQB CHASSIS MOUNT/DIN-RAIL

33-100W, WIDE INPUT RANGE

Features

- ◆ 33W-100W Isolated Output
- ◆ 4 : 1 Wide Input Range
- ◆ Chassis Mount/Din Rail Mount
- ◆ Input Over Voltage Protection
- ◆ Regulated Outputs
- ◆ Continuous Short Circuit Protection
- ◆ Safety Meets UL60950-1, EN60950-1, and IEC60950-1
- ◆ UL60950-1 Approval for DC Modules



QUARTER BRICK DC-DC CONVERTER WITH HEATSINK

Mechanical Dimensions

All Dimensions in Inches (mm)
 Tolerance Inches: X.XX=±0.02 , X.XXX=±0.010
 Millimeters: X.X=±0.5 , X.XX=±0.25

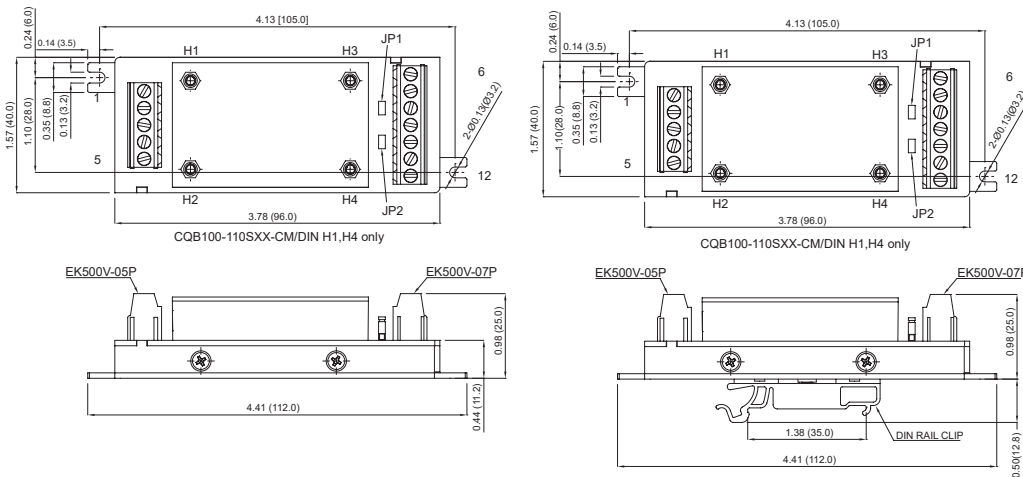

PIN CONNECTION	
PIN	Function
1,2	+V Input
3	On/Off
4,5	-V Input
6,7	+V Output
8	+Sense
9	Trim
10	-Sense
11,12	-V Output
JP1	Short +S& +V Output
JP2	Short -S& -V Output

MODEL NUMBER	INPUT
CQE50W-XXSXX-CM/DIN	220µF/100V for 24Vin Models 47µF/100V for 48Vin Models
CQB75W-XXSXX-CM/DIN	220µF/100V for 24Vin Models
CQB100W-XXSXX-CM/DIN	100µF/100V for 24Vin Models 47µF/100V for 48Vin Models
CQB100-110SXX-CM/DIN	120µF/200V
CQB150W-XXSXX-CM/DIN	470uF/50V for 24Vin Models 220uF/100V for 48Vin Models 220uF/200V for 110Vin Models

NOTE:

1. Short JP1 to connect +S and +Vo, JP2 to connect -S and -Vo with local sense.
2. Remove jumper(JP1& JP2),terminal block port +S, -S & Trim can be used to output remote sensing or output voltage adjustment functional(see application note).
3. Thermal resistance is referenced to the application note.
4. Include TVS for input surge voltage protection.
5. Recommend external fuse for input reverse polarity protection (Include shunt diode inside).
6. Suffix "DIN" to the model number with din mount, the clip is suitable f

Derating Curve

Typical Derating Curves At Nominal Line, Full Load, and natural convection

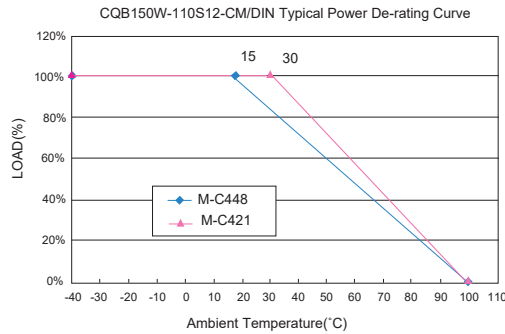
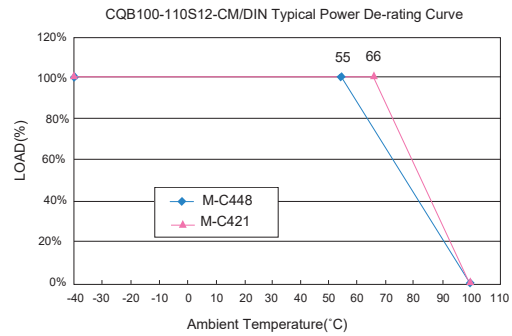
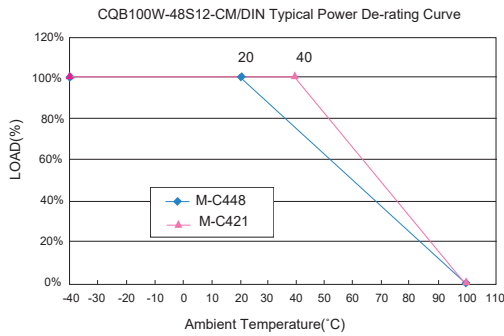
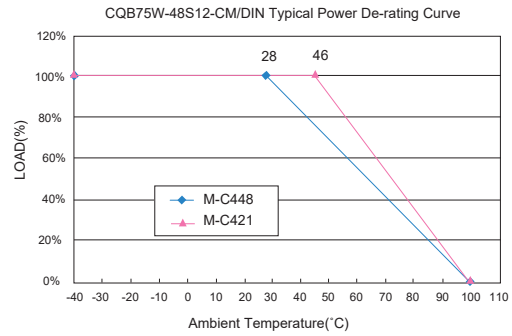
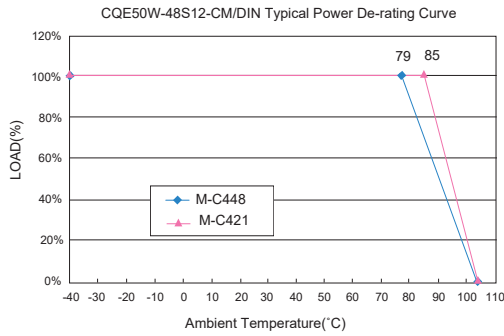

Ordering Information

Require input an aluminum capacitor connected in the table below.

Ordering Information						
CHB(E)XXX-	XX	S	XX	N	-XXX	+X-XXXX
Model No.	Nominal Input Voltage		Output Voltage	Remote On/Off		Heat Sink Type (Option)
CQE50W CQB75W CQB100W	24 : 24VDC 48 : 48VDC	Single Output	3V3 : 3.3VDC 05 : 5VDC 12 : 12VDC 15 : 15VDC 24 : 24VDC 48 : 48VDC	None: Positive Logic N: Negative Logic	CM: Chassis Mount DIN: Din Rail Mount	M-C448 M-C421
CQE50W			05 : 5VDC			
CQB100	110 : 110VDC		12 : 12VDC 24 : 24VDC			
CQB150W	24: 24VDC 48: 48VDC 110: 110VDC		12 : 12VDC 24 : 24VDC 28 : 28VDC 48 : 48VDC			

CHASSIS MOUNT CQB50W12 SERIES

30-50 WATT 12:1 INPUT DC-DC CONVERTERS

Features

- ◆ 30-50W Isolated Output
- ◆ Efficiency to 89%
- ◆ Fixed Switching Frequency
- ◆ 12:1 Input Range
- ◆ Regulated Outputs
- ◆ Remote On/Off
- ◆ Low No Load Power Consumption
- ◆ Over Temperature Protection
- ◆ Over Voltage/Current Protection
- ◆ Continuous Short Circuit Protection
- ◆ Shock & Vibration Meets EN50155 (EN61373)
- ◆ Safety Meets UL60950-1, EN60950-1 and IEC60950-1
- ◆ UL60950-1 2nd (Basic Insulation) Approval for DC Modules
- ◆ EN50155:2007 for EMC, Environmental and Characteristic
- ◆ Build-In EMI Filter
- ◆ Baseplate Cooled
- ◆ Fire & Smoke Meets EN45545-2

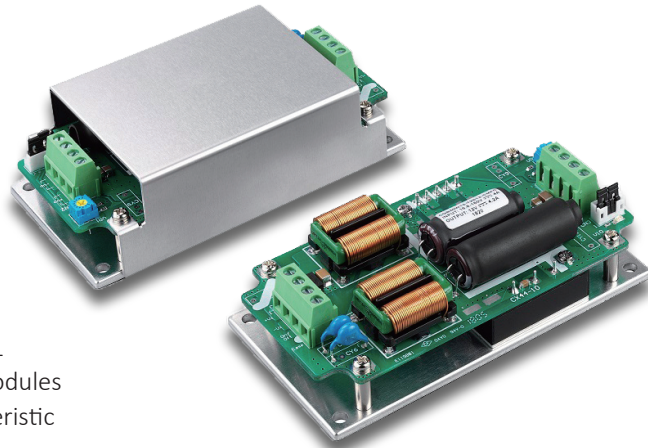

Mechanical Dimensions

All Dimensions in Inches(mm)
 Tolerance Inches: x.xx=±0.02, X.XXX=±0.010
 Millimeters: x.x=±0.5, XXX=±0.25

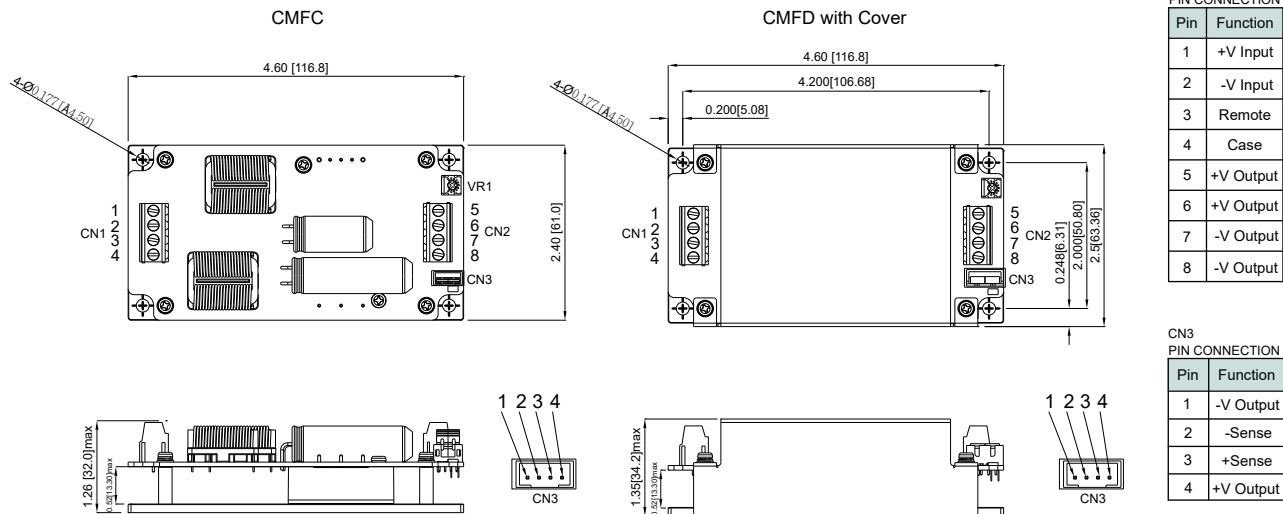

Pin	Function
1	+V Input
2	-V Input
3	Remote
4	Case
5	+V Output
6	+V Output
7	-V Output
8	-V Output

Pin	Function
1	-V Output
2	-Sense
3	+Sense
4	+V Output

MODEL NUMBER	INPUT VOLTAGE	OUTPUT VOLTAGE	OUTPUT CURRENT		INPUT CURRENT		% EFF.	CAPACITOR LOAD MAX.
			MIN.	MAX.	NO LOAD	FULL LOAD		
CQB50W12-72S05□-CMFC	14-160 VDC	5 VDC	0 mA	6.0 A	8 mA	530 mA	83	10000µF
CQB50W12-72S05□-CMFD								
CQB50W12-72S12□-CMFC	14-160 VDC	12 VDC	0 mA	4.2 A	8 mA	810 mA	87	6800µF
CQB50W12-72S12□-CMFD								
CQB50W12-72S24□-CMFC	14-160 VDC	24 VDC	0 mA	2.1 A	8 mA	800 mA	89	3300µF
CQB50W12-72S24□-CMFD								
CQB50W12-72S48□-CMFC	14-160 VDC	48 VDC	0 mA	1.05 A	12 mA	810 mA	88	680µF
CQB50W12-72S48□-CMFD								

NOTE:
 1. Nominal Input Voltage 72VDC
 2. □ = N or none
 3. VR1 is Used for Output Voltage Adjustment.
 4. Refer to Application Note for Thermal Resistance and Derating Informations.

5. TVS is Included for Input Surge Voltage Protection.
 6. Recommend an External Fuse for Input Reverse Polarity Protection (shunt diode is include inside).
 7. Input Voltage Range: 14-16.8 VDC (t ≤ 60 sec.)

Specifications

All Specifications Typical At Nominal Line, Full Load, and 25°C Unless Otherwise Noted

INPUT SPECIFICATIONS

Input Voltage Range	72V.....14-160V
Input Surge Voltage (100ms max.)	200Vdc max.
Under voltage lockout	power up14.6V power down12.6V

Positive Logic Remote On/Off (note4&5)

OUTPUT SPECIFICATIONS

Voltage Accuracy	±1.0% max.
Transient Response: 25% Step Load Change	<250µs
Trim Adj. Range (By VR1)	-20%,+10%
Ripple & Noise, 20MHz BW (see note 3)	40mV RMS, 100mV pk-pk max.
Temperature Coefficient	±0.02%/°C max.
Short Circuit Protection	Continuous
Line Regulation (note 1)	±0.2% max.
Load Regulation (note 2)	±0.2% max.
Over Voltage Protection trip Range, % Vo nom.	115-140%
Current Limit	110% ~220% Nominal Output
Start up Time	30ms typ.
Hold up Time	See Application Note

GENERAL SPECIFICATIONS

Efficiency	See Table
Isolation Voltage	Input/Output 3000VDC min. Input/Case 2500VDC min. Output/Case 500VAC min. 2x10 ⁸ ohm min.
Isolation Resistance	3000pF typ.
Isolation Capacitance	240KHz typ.
Switching Frequency	-40°C to +100°C
Operating Case Temperature	-40°C to +105°C
Storage Temperature	110°C typ.
Thermal Shutdown, Case Temp.	95% RH max. Non Condensing
Humidity	500Khrs typ.
MTBF ... MIL-HDBK-217F,GB, 25°C, Full Load	Meets UL60950-1
Safety	Meets EN50155(EN50121-3-2:2008)
EMC (note 5)	with External Output Filter Meets EN50155(EN50121-3-2:2015) Meets EN50155(EN61373) EN50155(EN60068-2-1, 2, 30)
Shock/Vibration	4.60×2.40×1.26 inches (116.8x61.0x32.0 mm)
Environmental	4.60×2.49×1.35 inches (116.8x63.4x34.2 mm)
Dimensions	
-CMFC	
-CMFD	
Case Material	Aluminum Base
-CMFC	Aluminum Base and Aluminum Cover
-CMFD	
Weight	
-CMFC	210g
-CMFD	296g

NOTE

1. Measured from high line to low line.
2. Measured from full load to zero load.
3. Output ripple and noise measured with 1µF ceramic capacitor across output.
4. Logic Compatibility open collector ref to -input
Module on >3.5Vdc to 160Vdc or open circuit
Module off 0 to<1.2Vdc
5. Suffix "N" to the model number with negative logic remote on/off
Module on 0 to< 1.2Vdc
Module off >4.0Vdc to 160Vdc or open circuit
6. Output connector CN3 wafer with TAIWAN KING PIN TERMINAL P110I series and mate with JST housing PH series or equivalent.
7. CN1 & CN2 connection: DINKLE EK500V-04P series or equivalent, suitable electric wire: 24~12AWG(IEC 0.5~2.5mm²).

CHASSIS MOUNT CQB150-300S SERIES

150 WATT 2:1 INPUT DC-DC CONVERTERS

Features

- ◆ 150W Isolated Output
- ◆ Efficiency to 89%
- ◆ Low No Load Power Consumption
- ◆ Fixed Switching Frequency
- ◆ Regulated Outputs
- ◆ Over Temperature Protection
- ◆ Over Voltage/Current Protection
- ◆ Remote On/Off
- ◆ Continuous Short Circuit Protection
- ◆ Shock & Vibration Meet EN61373
- ◆ Safety Meets IEC60950 and IEC62368
- ◆ UL60950-1 2nd (Reinforced Insulation) Approval for DC Modules
- ◆ Build-In EMI Filter
- ◆ Fire & Smoke Meet EN45545-2
- ◆ Baseplate cooled

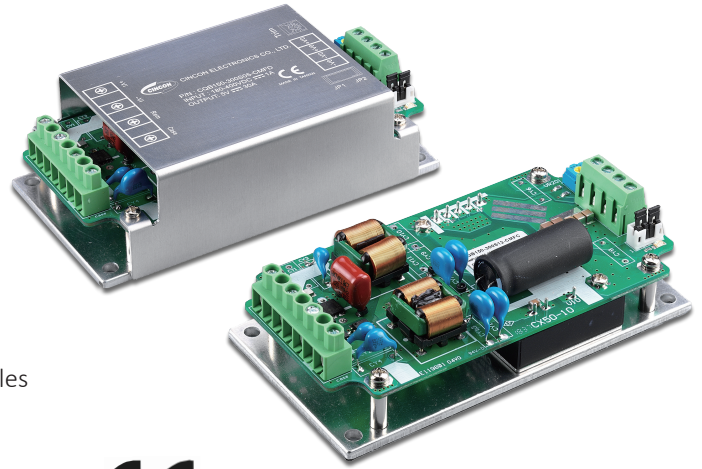

Mechanical Dimensions

All Dimensions in Inches(mm)
 Tolerance Inches: x.xx±0.02, X.XXX±0.010
 Millimeters: x.x±0.5, XXX±0.25

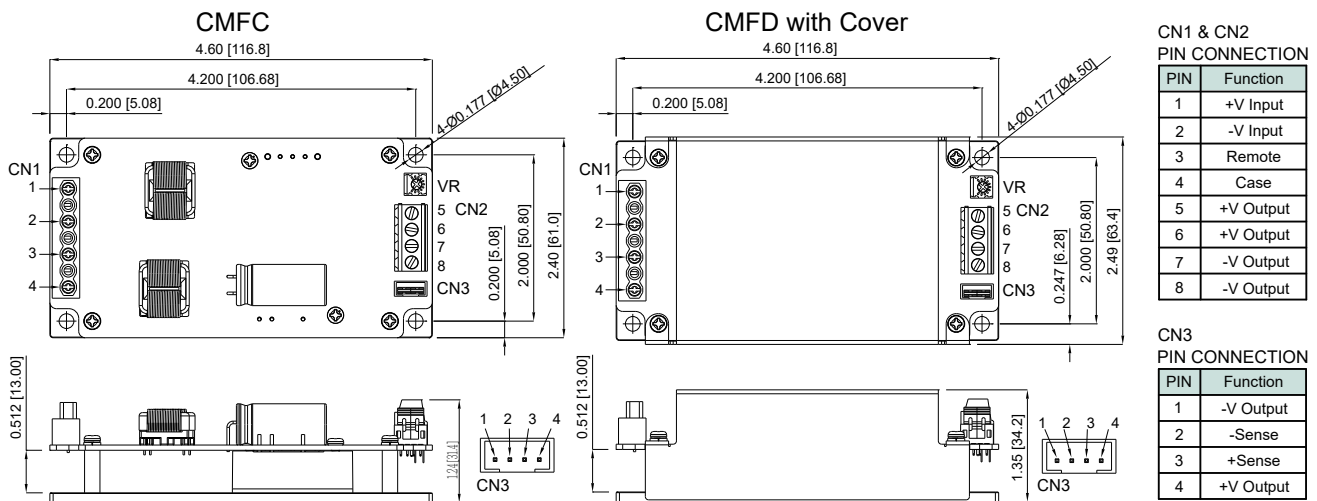

MODEL NUMBER	INPUT VOLTAGE	OUTPUT VOLTAGE	OUTPUT CURRENT		INPUT CURRENT		% EFF.	CAPACITOR LOAD MAX.
			MIN.	MAX.	NO LOAD	FULL LOAD		
CQB150-300S05□-CMFC	180-425 VDC	5 VDC	0 mA	30 A	10 mA	580 mA	85.5	10000μF
CQB150-300S05□-CMFD								
CQB150-300S12□-CMFC	180-425 VDC	12 VDC	0 mA	12.5 A	10 mA	560 mA	89	8800μF
CQB150-300S12□-CMFD								
CQB150-300S15□-CMFC	180-425 VDC	15 VDC	0 mA	10 A	10 mA	560 mA	89	8800μF
CQB150-300S15□-CMFD								
CQB150-300S24□-CMFC	180-425 VDC	24 VDC	0 mA	6.3 A	10 mA	570 mA	88.5	3300μF
CQB150-300S24□-CMFD								
CQB150-300S28□-CMFC	180-425 VDC	28 VDC	0 mA	5.4 A	10 mA	570 mA	88.5	3300μF
CQB150-300S28□-CMFD								
CQB150-300S48□-CMFC	180-425 VDC	48 VDC	0 mA	3.2 A	10 mA	570 mA	89	1000μF
CQB150-300S48□-CMFD								

NOTE:
 1. Nominal Input Voltage 300VDC
 2. □ = N or None
 3. VR is used for Output Voltage Adjustment.

4. Refer to application note for thermal resistance and derating informations.
 5. TVS is included for input surge voltage protection.
 6. Recommend an external fuse for input reverse polarity protection (shunt diode is included inside).

Specifications

All Specifications Typical At Nominal Line, Full Load, and 25°C Unless Otherwise Noted

INPUT SPECIFICATIONS

Input Voltage Range	300V 180-425V
Input Surge Voltage (100ms max.)	500Vdc max.
Under voltage lockout	300Vin power up 170V 300Vin power down 160.5V
Positive Logic Remote On/Off (note4&5)	

OUTPUT SPECIFICATIONS

Voltage Accuracy	±1.0% max.
Transient Response: 25% Step Load Change	<250µs
Trim Adj. Range (By VR1)	+10%,-20%
Ripple & Noise, 20MHz BW (see note 3)	
5V	60mV RMS, 120mV pk-pk max.
12V&15V	80mV RMS, 150mV pk-pk max.
24V&28V	100mV RMS, 200mV pk-pk max.
48V	150mV RMS, 300mV pk-pk max.
Temperature Coefficient	±0.02%/°C max.
Short Circuit Protection	Continuous
Line Regulation (note 1)	±0.2% max.
Load Regulation (note 2)	5V±0.5% max. Others±0.2% max.
Over Voltage Protection trip Range, % Vo nom.	115-140%
Current Limit	105%-140% Nominal Output
Start up Time	350ms typ.

GENERAL SPECIFICATIONS

Efficiency	See Table
Isolation Voltage	Input/Output 3000VAC min. Input/Case 2500VAC min. Output/Case 500VAC min.
Isolation Resistance	10 ⁸ ohm min.
Switching Frequency	360KHz typ.
Operating Case Temperature	-40°C to 100°C
Storage Temperature	-40°C to +105°C
Thermal Shutdown, Case Temp.(DC Mode)	110°C typ.
Humidity	95% RH max. Non condensing
MTBF ... MIL-STD-217F, GB, 25°C, Full Load	589 Khrs typ.
Safety	Meets UL60950-1
EMC	Meets EN55032/EN55022 Class A
Shock/Vibration	MIL-STD-810F/EN61373
Dimensions	
-CMFC	4.60x2.40x1.26 inches (116.8x61.0x32.0 mm)
-CMFD	4.60x2.49x1.35 inches (116.8x63.4x34.2 mm)
Case Material	
-CMFC	Aluminum Base
-CMFD	Aluminum Base and Aluminum Cover
Weight	
-CMFC	215g
-CMFD	300g

NOTE

1. Measured from high line to low line.
2. Measured from full load to zero load.
3. Output ripple and noise measured with 1µF ceramic capacitor across output.
4. Logic Compatibility open collector ref to -input
Module on >3.5Vdc to 12Vdc
Module off 0 to < 1.2Vdc or open circuit
5. Suffix "N" to the model number with negative logic remote on/off.
Module on 0 to < 1.2Vdc or open circuit
Module off >3.5Vdc to 12Vdc
6. Input connectors CN1connection: DINKLE 166-04P5 series or equivalent, suitable electric wire: 18~12AWG(IEC 0.5~4mm²).
7. Connector CN205 wafer with TAIWAN KING PIN TERMINAL P110I series and mate with JST housing PH series or equivalent.
8. Output connectors CN2 connection: DINKLE EK500V-04P series or equivalent,. suitable electric wire: 24~12AWG(IEC 0.5~2.5mm²).

CHASSIS MOUNT CQB150W-110S SERIES

150 WATT 4:1 INPUT DC-DC CONVERTERS

Features

- ◆ 150W Isolated Output
- ◆ Efficiency to 91%
- ◆ Fixed Switching Frequency
- ◆ 4 :1 Input Range
- ◆ Regulated Outputs
- ◆ Remote On/Off
- ◆ Low No Load Power Consumption
- ◆ Over Temperature Protection
- ◆ Over Voltage/Current Protection
- ◆ Continuous Short Circuit Protection
- ◆ Shock & Vibration Meet EN50155 (EN61373)
- ◆ Safety Meet UL60950-1, EN60950-1 and IEC60950-1
- ◆ UL60950-1 2nd (Basic Insulation) Approval for DC Modules
- ◆ EN50155:2007 for EMC, Environmental and Characteristic
- ◆ Build-In EMI Filter
- ◆ Fire & Smoke Meet EN45545-2

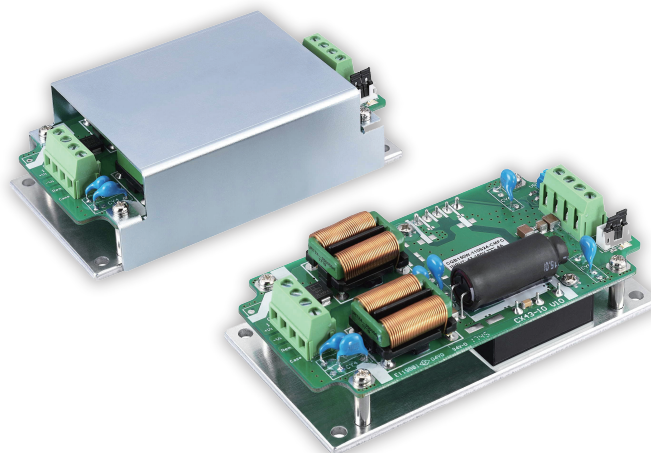

Mechanical Dimensions

All Dimensions In Inches (mm)
 Tolerance Inches: X.XX=±0.02, X.XXX=±0.010
 Millimeters: X.X=±0.5, X.XX=±0.25

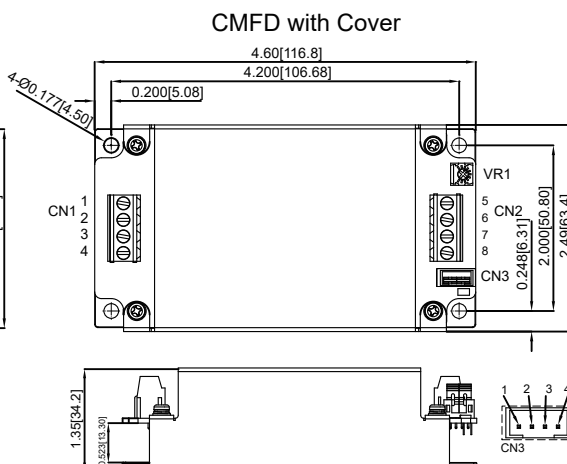
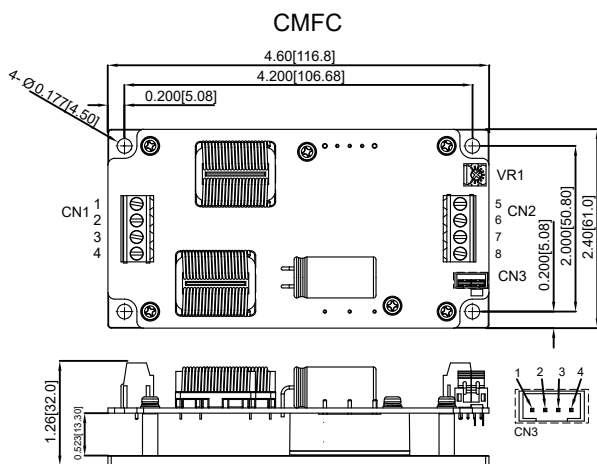

CN1&CN2 PIN CONNECTION	
PIN	Function
1	+V Input
2	-V Input
3	Remote
4	Case
5	+V Output
6	+V Output
7	-V Output
8	-V Output

CN3 PIN CONNECTION	
PIN	Function
1	-V Output
2	-Sense
3	+Sense
4	+V Output

MODEL NUMBER	INPUT VOLTAGE	OUTPUT VOLTAGE	OUTPUT CURRENT		INPUT CURRENT		% EFF.	CAPACITOR LOAD MAX.
			MIN.	MAX.	NO LOAD	FULL LOAD		
CQB150W-110S05□-CMFC CQB150W-110S05□-CMFD	43-160 VDC	5 VDC	0mA	30.0 A	15 mA	1.53 A	89	30000µF
CQB150W-110S12□-CMFC CQB150W-110S12□-CMFD	43-160 VDC	12 VDC	0mA	12.5 A	15 mA	1.50 A	91	12500µF
CQB150W-110S24□-CMFC CQB150W-110S24□-CMFD	43-160 VDC	24 VDC	0mA	6.3 A	15 mA	1.56 A	88	6300µF
CQB150W-110S28□-CMFC CQB150W-110S28□-CMFD	43-160 VDC	28 VDC	0mA	5.4 A	15 mA	1.56 A	88	5400µF
CQB150W-110S48□-CMFC CQB150W-110S48□-CMFD	43-160 VDC	48 VDC	0mA	3.2 A	15 mA	1.56 A	89.5	1000µF

NOTE:
 1. Nominal Input Voltage 110VDC
 2. □ = N or None.
 3. VR1 is used for Output Voltage Adjustment.
 4. Refer to application note for thermal resistance and derating informations.
 5. TVS is included for input surge voltage protection.
 6. Recommend an external fuse for input reverse polarity protection (shunt diode is included inside)

Specifications

All Specifications Typical at Nominal Line, Full Load, and 25°C Unless Otherwise Noted

INPUT SPECIFICATIONS

Input Voltage Range	110V 43-160V
Input Surge Voltage (100ms max.)	110V..... 200Vdc max.
Under voltage lockout	110Vin power up..... 41.5V
	110Vin power down..... 38.5V
Positive Logic Remote On/Off	See note 4 & 5

OUTPUT SPECIFICATIONS

Voltage Accuracy:	±1.0% max.
Transient Response: 25% Step Load Change	<250usec
Trim Adj. Range (By VR1)	±10%
Ripple & Noise, 20MHz BW	
5V&12V	40mV RMS, 100mV pk-pk max.
24V&28V	100mV RMS, 200mV pk-pk max.
48V	150mV RMS, 300mV pk-pk max.
Temperature Coefficient	±0.02%/°C max.
Short Circuit Protection	Continuous
Line Regulation (note 1)	±0.2% max.
Load Regulation (note 2)	5V.....±0.5% max.
	Others.....±0.2% max.
Over Voltage Protection Trip Range, % Vo nom.	115-140%
Current Limit	110%-160% Nominal Output
Start up time	100ms typ.
Hold up Time	See Application Note

GENERAL SPECIFICATIONS

Efficiency	See Table
Isolation Voltage	Input/Output 3000VDC min.
	Input/Case 2250VDC min.
	Output/Case 500VAC min.
Isolation Resistance	10 ⁸ ohm min.
Isolation Capacitance (DC Module)	1500pF typ
Switching Frequency	300KHz typ
Operating Case Temperature	-40°C to +100°C
Storage Temperature	-40°C to +105°C
Thermal Shutdown, Case Temperature(DC Module)	110°C typ.
Humidity	95% RH max. Non condensing
MTBF ... MIL-HDBK-217F, GB, 25°C, Full Load	600Khrs typ.
Safety	Meets UL60950-1
EMC	Meets EN50155(EN50121-3-2:2008)
	Meets EN50155(EN50121-3-2:2015)
	with External Output Filter
	Meets EN50155(EN61373)
Shock/Vibration	EN50155(EN60068-2-1,2,30)
Environmental	Aluminum Base
Case Material -CMFC	Aluminum Base and Aluminum Cover
-CMFD	4.60x2.40x1.26 inches
Dimensions -CMFC	(116.8x61.0x32.0 mm)
	4.60x2.49x1.35 Inches
	(116.8x63.4x34.2 mm)
	215g
Weight -CMFC	300g
-CMFD	

NOTE

1. Measured from high line to low line.
2. Measured from full load to zero load.
3. Output ripple and noise measured with 1uF ceramic capacitor across output.
4. Logic Compatibility open collector ref to -input
Module on >3.5Vdc to 160Vdc or open circuit
Module off 0 to < 1.2Vdc
5. Suffix "N" to the model number with negative logic remote on/off
Module on 0 to < 1.2Vdc
Module off >3.5Vdc to 160Vdc or open circuit
6. Output connector CN3 wafer with TAIWAN KING PIN TERMINAL P110I series and mate with JST housing PH series or equivalent.
7. CN1 & CN2 connection: DINKLE EK500V-04P series or equivalent, suitable electric wire: 24~12AWG(IEC 0.5~2.5mm²).

CHB CHASSIS MOUNT/DIN-RAIL

33-100W, WIDE INPUT RANGE

Features

- ◆ 33W-100W Isolated Output
- ◆ 4 : 1 Wide Input Range
- ◆ Chassis Mount/Din Rail Mount
- ◆ Input Over Voltage Protection
- ◆ Regulated Outputs
- ◆ Continuous Short Circuit Protection
- ◆ CE Mark Meets 2004/108/EEC
- ◆ Safety Meets UL60950-1, EN60950-1, and IEC60950-1
- ◆ UL60950-1 Approval for DC Modules (Excludes CHE75W, CHE100W and 28Vout)



HALF BRICK DC-DC CONVERTER WITH HEATSINK

Mechanical Dimensions

All Dimensions in Inches (mm)
 Tolerance Inches: X.XX=±0.02, X.XXX=±0.010
 Millimeters: X.X=±0.5, X.XX=±0.25

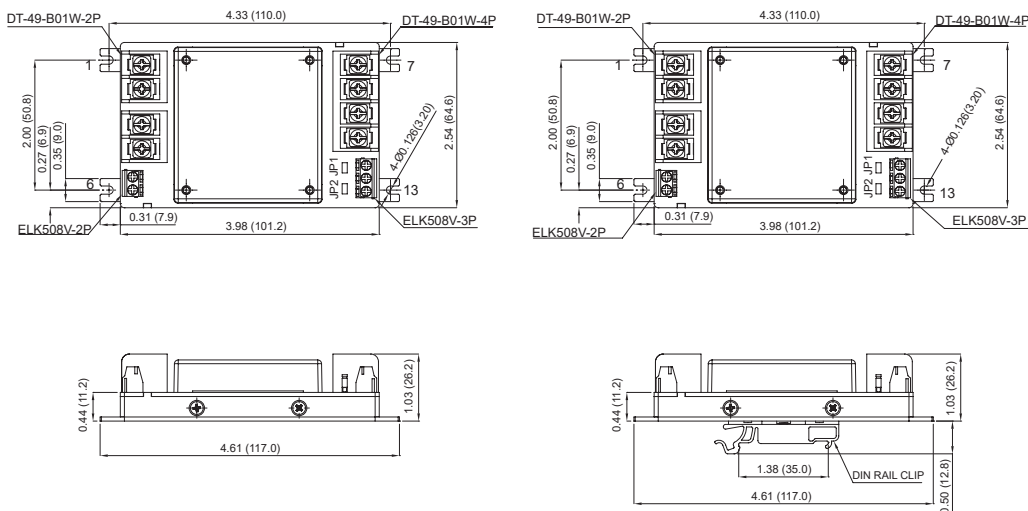

PIN CONNECTION	
PIN	Function
1,2	+V Input
3,4	-V Input
5	On/Off
6	CASE
7,8	+V Output
9,10	-V Output
11	+Sense
12	Trim
13	-Sense
JP1	Short +S& +V Output
JP2	Short -S& -V Output

MODEL NUMBER	INPUT	OUTPUT
CHB50W-XXSXX-CM/DIN	NC	47µF/100V for 48Vout Models Only
CHB75W-XXSXX-CM/DIN	47µF/100V for 48Vin Models	47µF/100V for 48Vout Models Only
CHE75W-XXSXX-CM/DIN	100uF/100V	10µF/100V for 48Vout Models Only
CHB100W-XXSXX-CM/DIN	100µF/100V for 24Vin Models 47µF/100V for 48Vout Models	47µF/100V for 48Vin Models
CHE100W-XXSXX-CM/DIN	220µF/100V	10µF/100V for 48Vout Models Only

NOTE:

1. Short JP1 to connect +S and +Vo, JP2 to connect -S and -Vo with local sense.
2. Remove jumper (JP1 & JP2), terminal block port +S, -S & Trim can be used to Output Remote Sensing or Output Voltage Adjustment functional (see application note).
3. Thermal resistance is referenced to the application note.
4. Include TVS for input surge voltage protection.
5. Recommend external fuse for input reverse polarity protection (Include shunt diode inside).
6. Suffix "DIN" to the Model number with din mount, the clip is suitable for TS-35 din rail.

Derating Curve

Typical Derating Curves At Nominal Line, Full Load, and natural convection

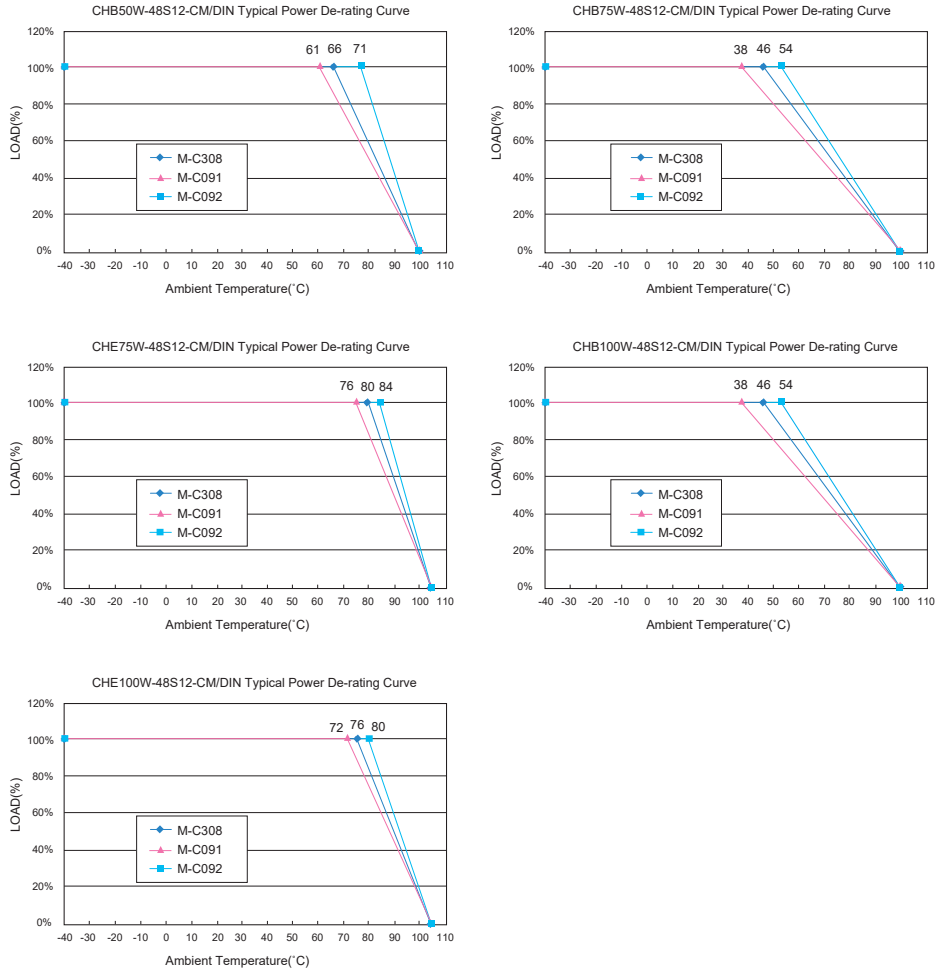

Ordering Information

Require input an aluminum capacitor connected in the table below.

Ordering Information						
CHB(E)XXX-	XX	S	XX	N	-XXX	+X-XXXX
Model No.	Nominal Input Voltage		Output Voltage	Remote On/Off		Heat Sink Type (Option)
CHB50W CHB75W CHE75W CHB100W CHE100W	24: 24VDC 48: 48VDC	Single Output	3V3 : 3.3VDC 05 : 5VDC 12 : 12VDC 15 : 15VDC 24 : 24VDC 48 : 48VDC	None: Positive Logic N: Negative Logic	CM: Chassis Mount DIN: Din Rail Mount	M-C308 M-C091 M-C092
CHB50W CHB75W CHB100W			28: 28VDC			

CHASSIS MOUNT CHB300W-110S SERIES

300 WATT 4:1 INPUT DC-DC CONVERTERS

Features

- ◆ 300W Isolated Output
- ◆ Efficiency to 90.5%
- ◆ Low No Load Power Consumption
- ◆ Fixed Switching Frequency
- ◆ 4 :1 Input Range
- ◆ Regulated Outputs
- ◆ Over Temperature Protection
- ◆ Over Voltage/Current Protection
- ◆ Remote On/Off
- ◆ Continuous Short Circuit Protection
- ◆ Shock & Vibration Meet EN50155 (EN61373)
- ◆ Safety Meets UL60950-1, EN60950-1, and IEC60950-1
- ◆ UL60950-1 2nd (Basic Insulation) Approval for DC Modules
- ◆ Meets EN50155:2007 for EMC, Environmental and Characteristic
- ◆ Build-In EMI Filter
- ◆ Fire & Smoke Meet EN45545-2
- ◆ Baseplate Cooled

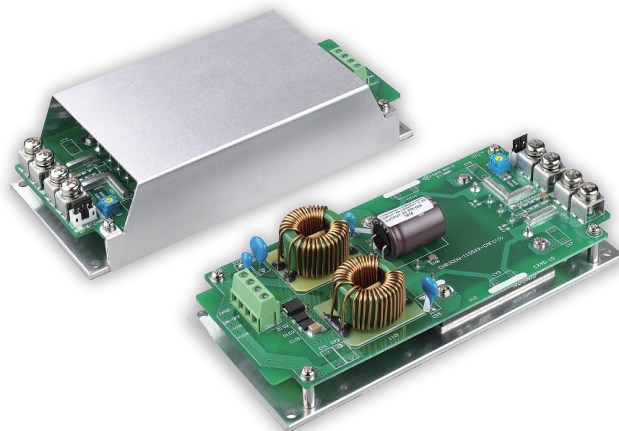

Mechanical Dimensions

All Dimensions In Inches (mm)

Tolerance Inches: X.XX= ±0.02 , X.XXX= ±0.010
Millimeters: X.X= ±0.5 , X.XX=±0.25

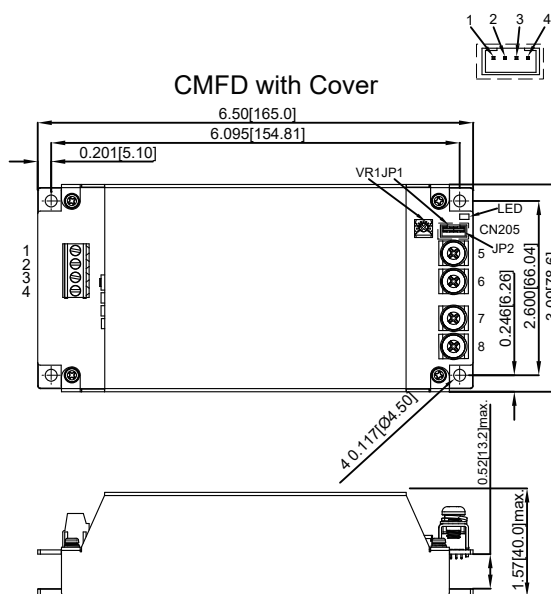
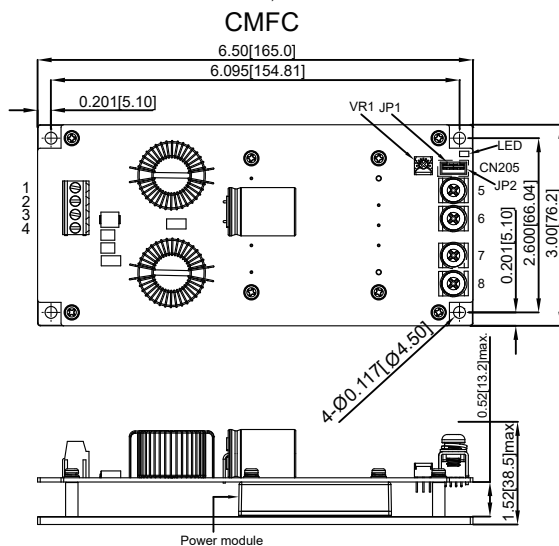

CN205: PIN CONNECTION	
PIN	Function
1	+Sense
2	+V Output
3	-Sense
4	-V Output

*JP1: Short PIN1 & PIN2
*JP2: Short PIN3 & PIN4

PIN CONNECTION	
PIN	Function
1	Case
2	On/Off
3	-V Input
4	+V Input
5	NP/-V Output
6	-V Output
7	+V Output
8	NP/+V Output

*PIN5 & 8 for 5Vo Only

MODEL NUMBER	INPUT VOLTAGE	OUTPUT VOLTAGE	OUTPUT CURRENT		INPUT CURRENT		% EFF.	CAPACITOR LOAD MAX.
			MIN.	MAX.	NO LOAD	FULL LOAD		
CHB300W-110S05□-CMFC CHB300W-110S05□-CMFD	43-160 VDC	5 VDC	0mA	60.0 A	15 mA	3153 mA	86.5	60000uF
CHB300W-110S12□-CMFC CHB300W-110S12□-CMFD	43-160 VDC	12 VDC	0mA	25.0 A	15 mA	3047 mA	89.5	25000µF
CHB300W-110S24□-CMFC CHB300W-110S24□-CMFD	43-160 VDC	24 VDC	0mA	12.5 A	15 mA	3064 mA	89	12500uF
CHB300W-110S28□-CMFC CHB300W-110S28□-CMFD	43-160 VDC	28 VDC	0mA	10.7A	15 mA	3060 mA	89	10700uF
CHB300W-110S48□-CMFC CHB300W-110S48□-CMFD	43-160 VDC	48 VDC	0mA	6.25A	15 mA	3013 mA	90.5	4700uF

NOTE:

1. Nominal Input Voltage 110VDC

2. □ = N or None

3. VR1 is used for Output Voltage Adjustment.

4. Refer to application note for thermal resistance and derating informations.

5. TVS is included for input surge voltage protection.

6. Recommend an external fuse for input reverse polarity protection (shunt diode is include inside).

Specifications

All Specifications Typical At Nominal Line, Full Load, and 25°C Unless Otherwise Noted

INPUT SPECIFICATIONS

Input Voltage Range	110V.....43-160V
Input Surge Voltage (100ms max.)	200Vdc max.
Under voltage lockout	110Vin Power up.....42V 110Vin Power down.....39.5V
Positive Logic Remote On/Off	See note 4 & 5

OUTPUT SPECIFICATIONS

Voltage Accuracy:	±1.0% max.
Transient Response: 25% Step Load Change	<250usec
Trim Adj. Range (By VR1)	±10%
Ripple & Noise, 20MHz BW (note3)	
5V	60mV RMS, 120mV pk-pk max
12V	80mV RMS, 150mV pk-pk max.
24V&28V	100mV RMS, 200mV pk-pk max.
48V	150mV RMS, 300mV pk-pk max.
Temperature Coefficient	±0.02%/°C max.
Short Circuit Protection	Continuous
Line Regulation (note 1)	±0.2% max.
Load Regulation (note 2)	5V..... ±0.5% max. Others..... ±0.2% max.
Over Voltage Protection trip Range, % Vo nom.	115-140%
Current Limit	110%-160% Nominal Output
Start up time	50mS typ.
Hold up Time	See Application Note

GENERAL SPECIFICATIONS

Efficiency	See Table
Isolation Voltage	Input/Output 3000VDC min. Input/Case 3000VDC min. Output/Case 500VAC min.
Isolation Resistance	10 ⁸ ohm min.
Isolation Capacitance	8000pF typ
Switching Frequency	300KHz typ
Operating Case Temperature	-40°C to 100°C
Storage Temperature	-40°C to +105°C
Thermal Shutdown, Case Temperature(DC Module)	110°C typ.
Humidity	95% RH max. Non Condensing
MTBF ... MIL-HDBK-217F, GB, 25°C, Full Load	460Khrs typ.
Safety	Meets UL60950-1
EMC	Meets EN50155(EN50121-3-2:2008) with External Output Filter Meets EN50155(EN50121-3-2:2015) EN50155(EN61373) EN50155(EN60068-2-1,2,30)
Shock/Vibration	Aluminum Base
Environmental	Aluminum Base and Aluminum Cover
Case Material -CMFC	6.50×3.00×1.52 Inches (165.0×76.2×38.5mm)
-CMFD	6.50×3.09×1.57 Inches (165.0×78.6×40.0mm)
Dimensions -CMFC	380g
-CMFD	435g
Weight -CMFC	
-CMFD	

NOTE

1. Measured from high line to low line.
2. Measured from full load to zero load.
3. Output ripple and noise measured with 1uF ceramic capacitor across output.
4. Logic Compatibility open collector ref to -input
Module on >3.5Vdc to 160Vdc or open circuit
Module off 0 to < 1.2Vdc
5. Suffix "N" to the model number with negative logic remote on/off.
Module on 0 to < 1.2Vdc
Module off >3.5Vdc to 160Vdc or open circuit
6. Input connectors PIN1~4 use DINKLE EK500V-04P series or equivalent, suitable electric wire: 24~10AWG(IEC 0.5~2.5mm²).
7. Connector CN205 wafer with TAIWAN KING PIN TERMINAL P1101 series and mate with JST housing PH series or equivalent.
8. Output connectors PIN5~8 use M5 terminal screw.

CHASSIS MOUNT CHB300-300S SERIES

300 WATT 2:1 INPUT DC-DC CONVERTERS

Features

- ◆ 300W Isolated Output
- ◆ Efficiency to 90%
- ◆ Low No Load Power Consumption
- ◆ Fixed Switching Frequency
- ◆ Regulated Outputs
- ◆ Over Temperature Protection
- ◆ Over Voltage/Current Protection
- ◆ Remote On/Off
- ◆ Continuous Short Circuit Protection
- ◆ Shock & Vibration Meet EN61373
- ◆ Safety Meets IEC60950 and IEC62368
- ◆ UL60950-1 2nd (Reinforced Insulation) Approval for DC Modules
- ◆ Build-In EMI Filter
- ◆ Fire & Smoke Meet EN45545-2
- ◆ Baseplate cooled

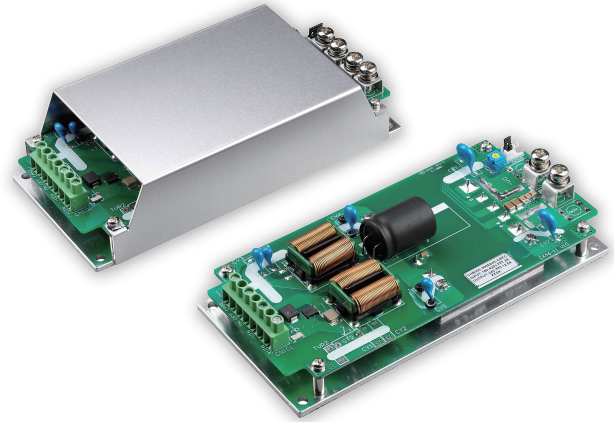

Mechanical Dimensions

All Dimensions In Inches (mm)
 Tolerance Inches: X.XX= ±0.02, X.XXX= ±0.010
 Millimeters: X.X= ±0.5, X.XX=±0.25

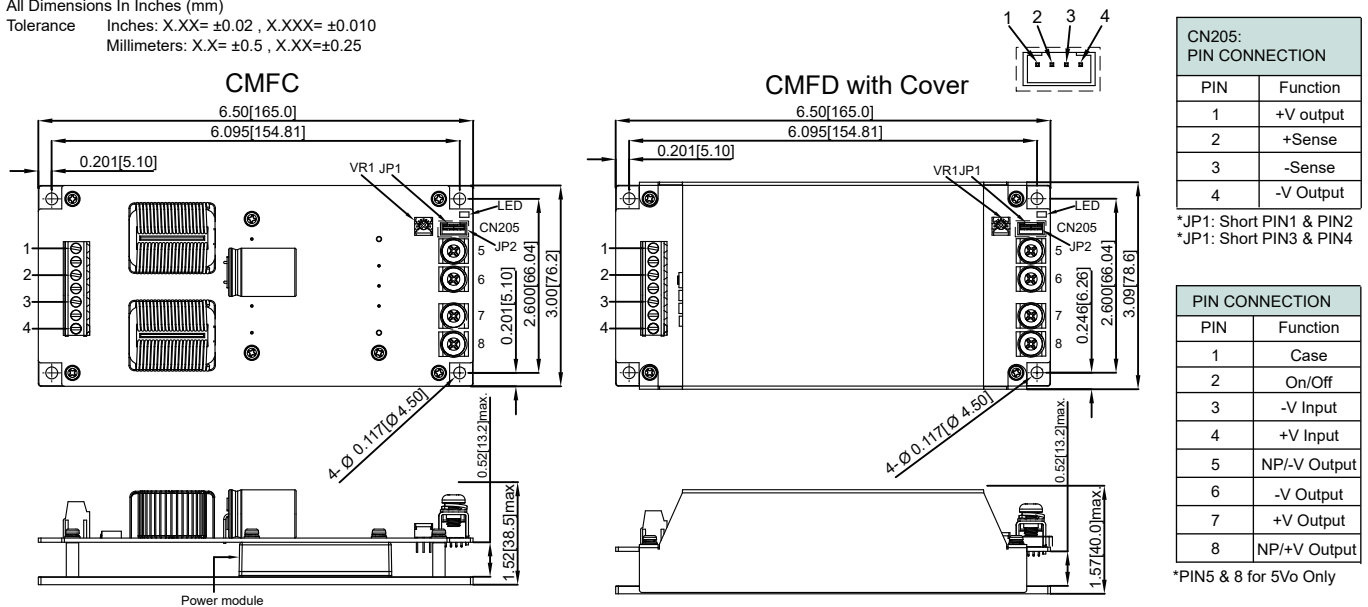

MODEL NUMBER	INPUT VOLTAGE	OUTPUT VOLTAGE	OUTPUT CURRENT		INPUT CURRENT		% EFF.	CAPACITOR LOAD MAX.
			MIN.	MAX.	NO LOAD	FULL LOAD		
CHB300-300S05□-CMFC CHB300-300S05□-CMFD	180-425 VDC	5 VDC	0mA	60.0 A	15 mA	1920 mA	88.5	10000µF
CHB300-300S12□-CMFC CHB300-300S12□-CMFD	180-425 VDC	12 VDC	0mA	25.0 A	15 mA	1920 mA	87.5	10000µF
CHB300-300S24□-CMFC CHB300-300S24□-CMFD	180-425 VDC	24 VDC	0mA	12.5 A	15 mA	1870 mA	90	6000µF
CHB300-300S28□-CMFC CHB300-300S28□-CMFD	180-425 VDC	28 VDC	0mA	10.7 A	15 mA	1870 mA	90	6000µF
CHB300-300S48□-CMFC CHB300-300S48□-CMFD	180-425 VDC	48 VDC	0mA	6.25 A	15 mA	1870 mA	90	3000µF

NOTE:
 1. Nominal Input Voltage 300VDC
 2. □ = N or None
 3. VR1 is used for Output Voltage Adjustment.
 4. Refer to application note for thermal resistance and derating informations.
 5. TVS is included for input surge voltage protection.
 6. Recommend an external fuse for input reverse polarity protection (shunt diode is included inside).

Specifications

All Specifications Typical At Nominal Line, Full Load, and 25°C Unless Otherwise Noted

INPUT SPECIFICATIONS

Input Voltage Range	300V180-425V
Input Surge Voltage (100ms max.)	500Vdc max.
Under voltage lockout	300Vin Power up..... 170V 300Vin Power down.....160.5V
Positive Logic Remote On/Off	See note 4 & 5

OUTPUT SPECIFICATIONS

Voltage Accuracy:	±1.0% max.
Transient Response: 25% Step Load Change	<250us
Trim Adj. Range (By VR1)	±10, -20%
Ripple & Noise, 20MHz BW (note3)	
5V	60 mV RMS, 120mV pk-pk max.
12V	80 mV RMS, 150mV pk-pk max.
24V&28V	100mV RMS, 200mV pk-pk max.
48V	150mV RMS, 300mV pk-pk max.
Temperature Coefficient	±0.02%/°C max.
Short Circuit Protection	Continuous
Line Regulation (note 1)	±0.2% max.
Load Regulation (note 2)	5V.....±0.5% max. Others.....±0.2% max.
Over Voltage Protection trip Range, % Vo nom.	115-140%
Current Limit	105%-140% Nominal Output
Start up time	350ms typ.

GENERAL SPECIFICATIONS

Efficiency	See Table
Isolation Voltage	Input/Output 3000VAC min. Input/Case 2500VAC min. Output/Case 500VAC min.
Isolation Resistance	10 ⁸ ohm min.
Switching Frequency	300KHz typ
Operating Case Temperature	-40°C to 100°C
Storage Temperature	-40°C to +105°C
Thermal Shutdown, Case Temperature(DC Module)	105°C typ.
Humidity	95% RH max. Non condensing
MTBF ... MIL-HDBK-217F, GB, 25°C, Full Load	537Khrs typ.
Safety	Meets UL60950-1
EMC	Meets EN55032/EN55022 Class A
Shock/Vibration	MIL-STD-810F / EN61373
Case Material -CMFC	Aluminum Base
-CMFD	Aluminum Base and Aluminum Cover
Dimensions -CMFC	6.50×3.00×1.52 Inches (165.0×76.2×38.5mm)
-CMFD	6.50×3.09×1.57 Inches (165.0×78.6×40.0mm)
Weight -CMFC	380g
-CMFD	435g

NOTE

1. Measured from high line to low line.
2. Measured from full load to zero load.
3. Output ripple and noise measured with 1uF ceramic capacitor across output.
4. Logic Compatibility open collector ref to -input
Module on >3.5Vdc to 12Vdc
Module off 0 to < 1.2Vdc or open circuit
5. Suffix "N" to the model number with negative logic remote on/off.
Module on 0 to < 1.2Vdc or open circuit
Module off >3.5Vdc to 12Vdc
6. Input connectors PIN1~4 use DINKLE 166-04P5 series or equivalent,
suitable electric wire: 18~12AWG(IEC 0.5~4mm²).
7. Connector CN205 wafer with TAIWAN KING PIN TERMINAL P110I
series and mate with JST housing PH series or equivalent.
8. Output connectors PIN5~8 use M5 terminal screw.

CHASSIS MOUNT CFB600W-110S SERIES

CFB600 WATT 4:1 INPUT DC-DC CONVERTERS

Features

- ◆ 600W Isolated Output
- ◆ Efficiency to 88%
- ◆ Fixed Switching Frequency
- ◆ 4:1 Input Range
- ◆ Regulated Outputs
- ◆ Remote On/Off
- ◆ Over Temperature Protection
- ◆ Over Voltage/Current Protection
- ◆ Continuous Short Circuit Protection
- ◆ Shock & Vibration Meets EN50155 (EN61373)
- ◆ Safety Meets UL60950-1, EN60950-1, and IEC60950-1
- ◆ UL60950-1 2nd (Basic Insulation) Approval for DC Modules
- ◆ Build-In EMI Filter
- ◆ Fire & Smoke Meet EN45545-2
- ◆ Baseplate cooled

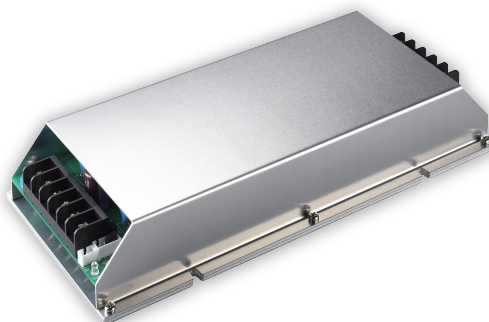

Mechanical Dimensions

All Dimensions In Inches (mm)
 Tolerance Inches: X.XX= ±0.02 , X.XXX= ±0.010
 Millimeters: X.X= ±0.5 , X.XX=±0.25

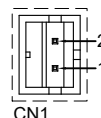
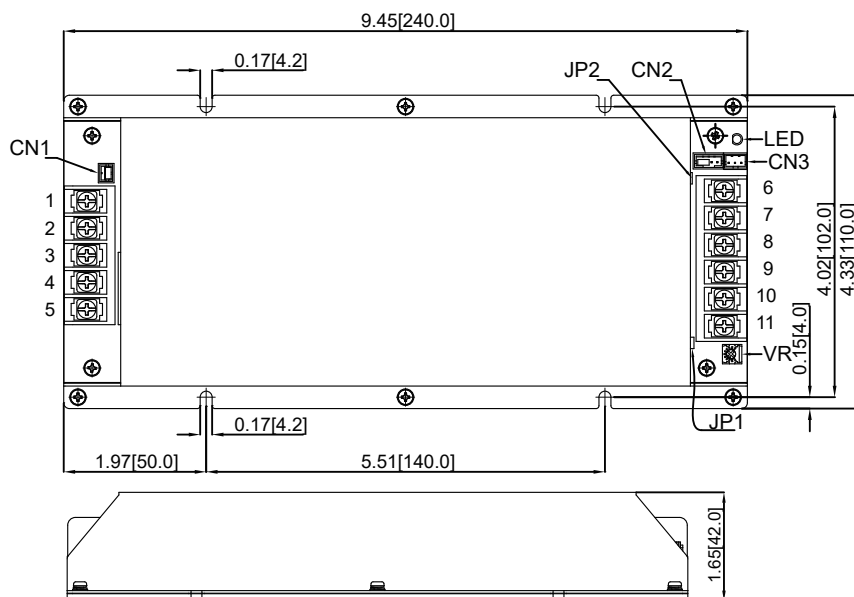

CN1 (On/Off JP)	
PIN CONNECTION	
PIN	Function
1	-V Input
2	-On/Off

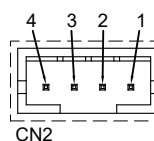

CN2 (Trim JP)	
PIN CONNECTION	
PIN	Function
1	-Sense
2	+Sense
3	Trim
4	Rt

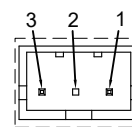

PIN CONNECTION	
PIN	Function
1	PE
2,3	-V Input
4,5	+V Input
6,7,8	-V Output
9,10,11	+V Output
JP1	Short +S&+Vo
JP2	Short -S&-Vo

CN3 (PC JP)	
PIN CONNECTION	
PIN	Function
1	AUX
2	IOG
3	PC

MODEL NUMBER	INPUT VOLTAGE	OUTPUT VOLTAGE	OUTPUT CURRENT		INPUT CURRENT		% EFF.	CAPACITOR LOAD MAX.
			MIN.	MAX.	NO LOAD	FULL LOAD		
CFB600W-110S12□-CMFD	43-160 VDC	12 VDC	0mA	50 A	25 mA	6.3 A	87	10000µF
CFB600W-110S24□-CMFD	43-160 VDC	24 VDC	0mA	25 A	25 mA	6.2 A	88	10000µF
CFB600W-110S28□-CMFD	43-160 VDC	28 VDC	0mA	21.4 A	25 mA	6.2 A	88	10000µF
CFB600W-110S48□-CMFD	43-160 VDC	48 VDC	0mA	12.5 A	25 mA	6.2 A	88	10000µF

NOTE:
 1. Nominal Input Voltage 300VDC
 2. □ = P or None
 3. VR is used for Output Voltage Adjustment.
 4. Refer to Application Note for Thermal Resistance and Derating Informations.
 5. TVS is Included for Input Surge Voltage Protection
 6. Recommend an External Fuse for Input Reverse Polarity Protection (shunt diode is include inside).

Specifications

All Specifications Typical At Nominal Line, Full Load, and 25°C Unless Otherwise Noted

INPUT SPECIFICATIONS

Input Voltage Range	110V43-160V
Input Surge Voltage (100ms max.)	110V180Vdc max.
Under voltage lockout	110Vin power up 42V
	110Vin power down 40V
Remote ON/OFF	See note 4

OUTPUT SPECIFICATIONS

Voltage Accuracy:	±1.0% max.
Transient Response: 25% Step Load Change	<500us
Trim Adj. Range (By VR)	±10%
Ripple & Noise, 20MHz BW	
12V	60 mV RMS, 120mV pk-pk max.
24V	100mV RMS, 240mV pk-pk max.
28V	100mV RMS, 280mV pk-pk max.
48V	200mV RMS, 480mV pk-pk max.
Temperature Coefficient	±0.03%/°C max.
Short Circuit Protection	Continuous
Line Regulation (note 1)	±0.2% max.
Load Regulation (note 2)	±2.0% max.
Over Voltage Protection trip Range, % Vo nom.	115-140%
Current Limit	105%-140% Nominal Output
Auxiliary Output Voltage/Current	10±3Vdc/20mA max.
Load Share Accuracy	±10% at 50% to 100% Full Load
Start up time	160ms typ.

GENERAL SPECIFICATIONS

Efficiency	See Table
Isolation Voltage	Input/Output 2250VDC min.
	Input/Case 2250VDC min.
	Output/Case 1500VDC min.
Isolation Resistance	10 ⁷ ohm min.
Isolation Capacitance (DC Module)	4000pF typ
Switching Frequency	250KHz typ
Operating Case Temperature	- 40°C to +100°C
Storage Temperature	- 40°C to +105°C
Thermal Shutdown, Case Temperature(DC Module)	110°C typ.
Humidity	95% RH max. Non condensing
MTBF ... MIL-HDBK-217F, GB, 25°C, Full Load	280Khrs typ.
Safety	Meets UL60950-1 2 nd (Basic insulation)
EMC	Meets EN50155(EN50121-3-2:2007) with External Output Filter Meets EN50155(EN50121-3-2:2015) Meets EN50155(EN61373) EN50155(EN60068-2-1,2,30)
Shock/Vibration	Aluminum
Environmental	9.45×4.33×1.65 Inches (240.0×110.0×42.0mm)
Case Material	
Dimensions	
Weight	995g

NOTE

1. Measured from high line to low line.
2. Measured from full load to zero load
3. Output ripple and noise measured with 1uF ceramic capacitor across output.
4. Suffix "P" to the model number with positive logic remote on/off, standard model is negative logic
5. Input connectors PIN1-5 use DINKLE DT-49-B01W-05 series or equivalent. suitable electric wire: 22-12AWG(IEC 0.5-4mm²)
6. Output connectors PIN6-11 use DINKLE DT-49-B01W-06 series or equivalent. suitable electric wire: 22-12AWG(IEC 0.5-4mm²)
7. Connector CN1 wafer with TAIWAN KING PIN TERMINAL 8822-02 series or equivalent
8. Connector CN2 wafer with CHYAO SHIUNN TERMINAL JS-1001-04(K) series or equivalent.
9. Connector CN3 wafer with CHIA-SOON TERMINAL B3B-PH-K-S series or equivalent

FM SERIES

10 AMP & 20 AMP, FILTER MODULE

Features

- ◆ Compact Size 2" x 1", 2" x 1.6"
- ◆ PCB Mount
- ◆ 10A and 20A Filter Module
- ◆ 75VDC Input Voltage Maximum
- ◆ Suitable for Use With Half Brick and Quarter Brick Series



Mechanical Dimensions

NOTE: Pin Size is 0.04 Inch (1.02 mm) DIA
 All Dimensions in Inches (mm)
 Tolerance Inches: X.XX=±0.02, X.XXX=±0.010
 Millimeters: X.X=±0.5, X.XX=±0.25

Typical Common-mode and Differential-mode Loss for FM10-100

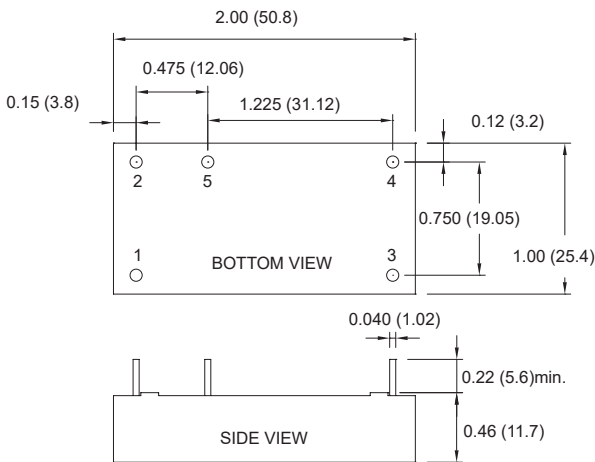

PIN CONNECTION	
PIN	Function
1	+V Input
2	-V Input
3	+V Output
4	-V Output
5	GND

Typical Common-mode and Differential-mode Loss for FM20-100

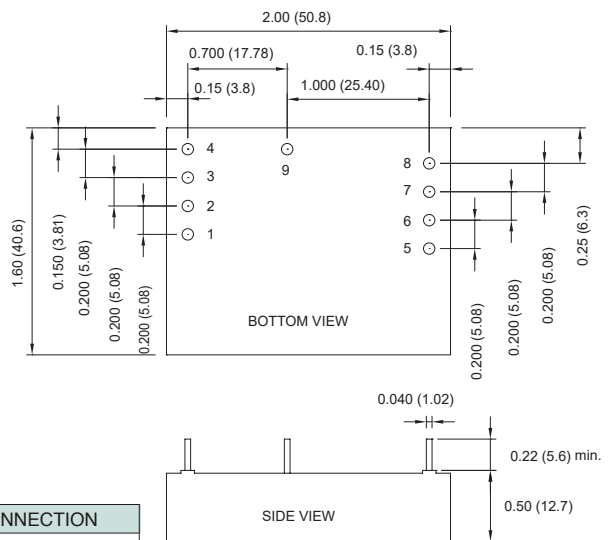

PIN CONNECTION	
PIN	Function
1,2	+V Input
3,4	-V Input
5,6	+V Output
7,8	-V Output
9	GND

MODEL NUMBER	INPUT VOLTAGE	INPUT SURGE VOLTAGE	OUTPUT RATED CURRENT	DC RESISTANCE (+Vin to +Vo)	DC RESISTANCE (-Vin to -Vo)
FM10-100	75 VDC max.	100 VDC max.	10 A max.	11.5 mΩ typ.	4.5 mΩ typ.
FM20-100	75 VDC max.	100 VDC max.	20 A max.	9.5 mΩ typ.	5.7 mΩ typ.

Derating Curve

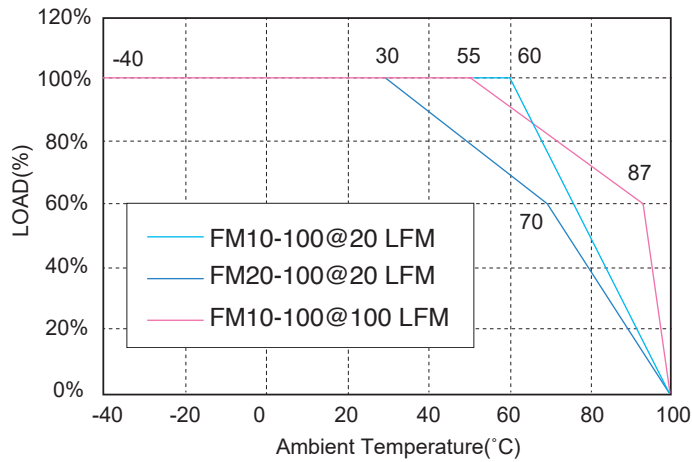

Specifications

All Specifications Typical At Nominal Line, Full Load, and 25°C Unless Otherwise Noted

INPUT SPECIFICATIONS

Input Voltage Range	75Vdc max.
Input Surge Voltage	100Vdc/100ms
Input Rated Current	See Table

NOTE

1. Maximum case temperature under any operating condition should not exceed 100°C.

GENERAL SPECIFICATIONS

Isolation Voltage	Input/GND..... 1500Vdc min. Output/GND.....500Vdc min.
Isolation Resistance	10 ⁷ ohm min.
DC Resistance	See Table
Operating Case Temperature Range (note 1)	-40°C to +100°C
Storage Temperature Range	-55°C to +105°C
Dimensions:	

FM10: 2.00 x 1.00 x 0.46 inches (50.8 x 25.4 x 11.7 mm)
FM20: 2.00 x 1.60 x 0.50 inches (50.8 x 40.6 x 12.7 mm)
Plastic Case with Epoxy Potting
FM10: 30 g
FM20: 55 g

Case Materials
Weight

Typical Common-mode and Differential-mode Loss for FM10-100

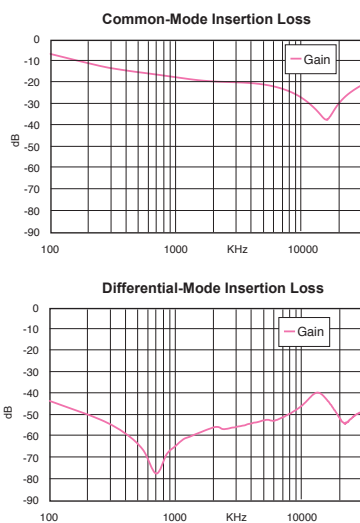

Typical Common-mode and Differential-mode Loss for FM20-100

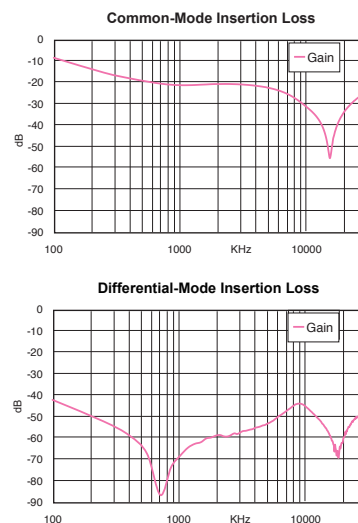

FM SERIES

30 AMP OUTPUT FILTER MODULE

Features

- ◆ Compact Size 2.28"x1.45"
- ◆ Quarter-Brick Size
- ◆ Six-Sided Shield Metal Case
- ◆ PCB Mount
- ◆ 30A Filter Module
- ◆ 80VDC Input Voltage Maximum
- ◆ Suitable for EN50121-3-2:2015 Output Specification
- ◆ Fire & Smoke Meets EN45545-2



Mechanical Dimensions

All Dimensions In Inches[mm]
 Tolerance Inches:x.xx= ±0.02, x.xxx= ±0.010
 Millimeters:x.x= ±0.5, x.xx=±0.25

BOTTOM VIEW

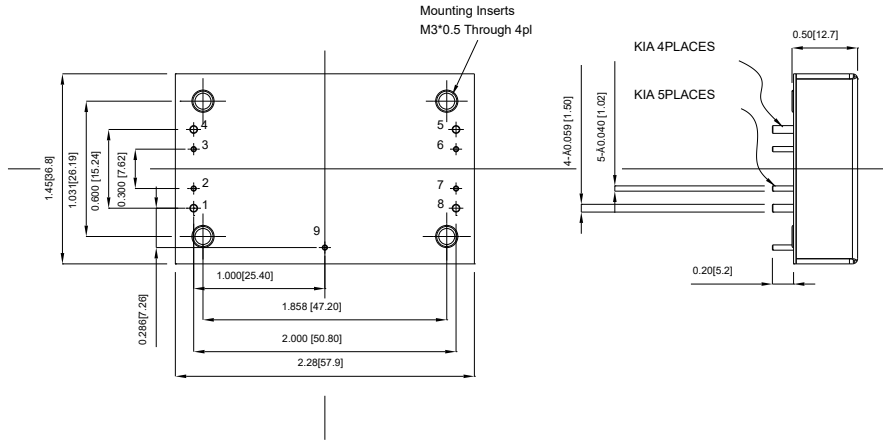

PIN CONNECTION	
PIN	Function
1	+V Input
2,7	+Sense
3,6	-Sense
4	-V Input
5	-V Output
8	+V Output
9	Case

MODEL NUMBER	INPUT VOLTAGE	INPUT SURGE VOLTAGE	OUTPUT RATED CURRENT	DC RESISTANCE (+Vin to +Vo)	DC RESISTANCE (-Vin to -Vo)
--------------	---------------	---------------------	----------------------	-----------------------------	-----------------------------

FM30R080P	80 VDC max.	100 VDC max.	30 A max.	3.0 mΩ typ.	3.0 mΩ typ.
-----------	-------------	--------------	-----------	-------------	-------------

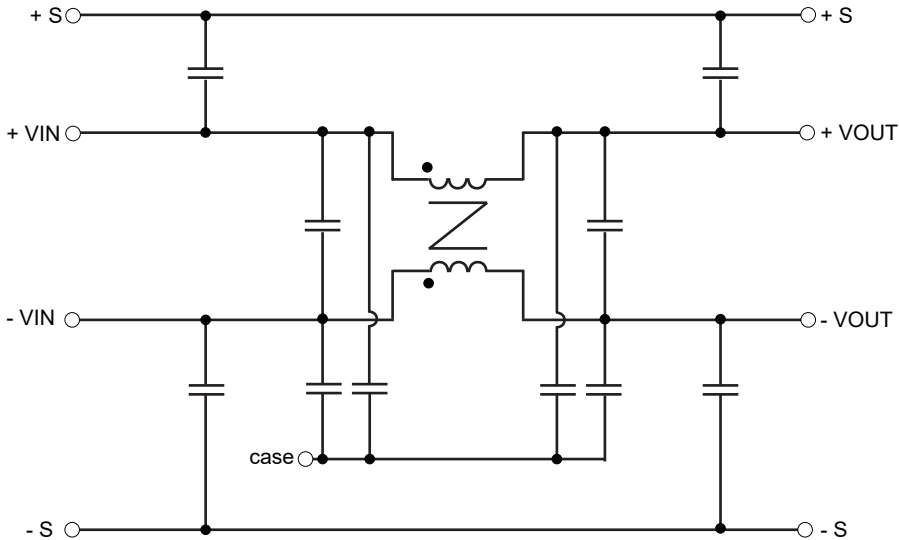

Schematic for FM30R080P Module

Derating Curve

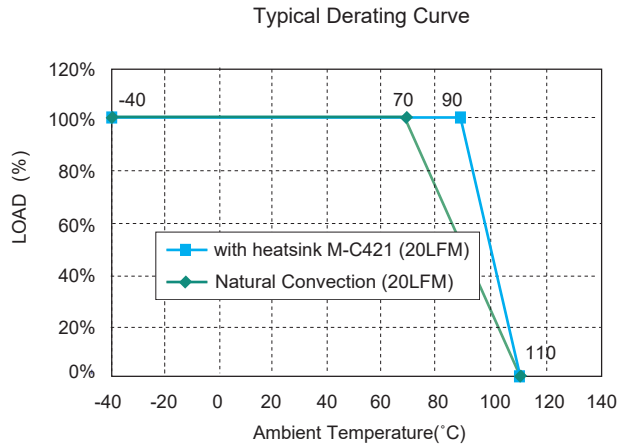

Specifications

All Specifications Typical At Nominal Line, Full Load, and 25°C Unless Otherwise Noted

INPUT SPECIFICATIONS

Input Voltage Range	80Vdc max.
Input Surge Voltage	100Vdc/1s
Input Rated Current (note 1)	30A max.

GENERAL SPECIFICATIONS

Isolation Voltage	Input/Case/Output/Case	1000Vdc min.
Isolation Resistance		10 ⁸ ohm min.
DC Resistance		See Table
Operating Case Temperature Range (note1)		-40°C to +110°C
Storage Temperature Range		-55°C to +125°C
Dimensions		2.28x1.45x0.50inches (57.9 x 36.8 x 12.7 mm)
Case Material		Aluminum with Non-Conducted Base
Weight		60 g

NOTE

NOTE :
1. Maximum case temperature under any operating condition should not exceed 110°C.

Typical Common-mode Loss for FM30R080P



Typical Differential-mode Loss for FM30R080P



FM10D200P SERIES

10 AMP FILTER MODULE

Features

- ◆ Half Brick Size Meet Industrial Standard
- ◆ PCB Mount
- ◆ 10A Filter Module
- ◆ 200VDC Input Voltage Maximum
- ◆ All capacitor are multi-layer ceramic
- ◆ Fire & Smoke Meets EN45545-2

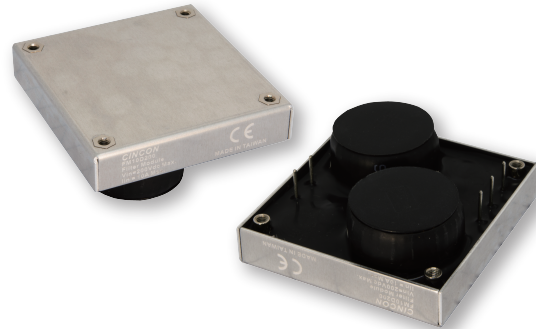

Mechanical Dimensions

NOTE: Pin Size is 0.04±0.004 Inch (1.0±0.1mm) DIA
 All Dimensions In Inches[mm]
 Tolerance Inches: x.xx = ± 0.02 ,x.xxx = ± 0.010
 Millimeters: x.x = ± 0.5 ,x.xx = ± 0.25

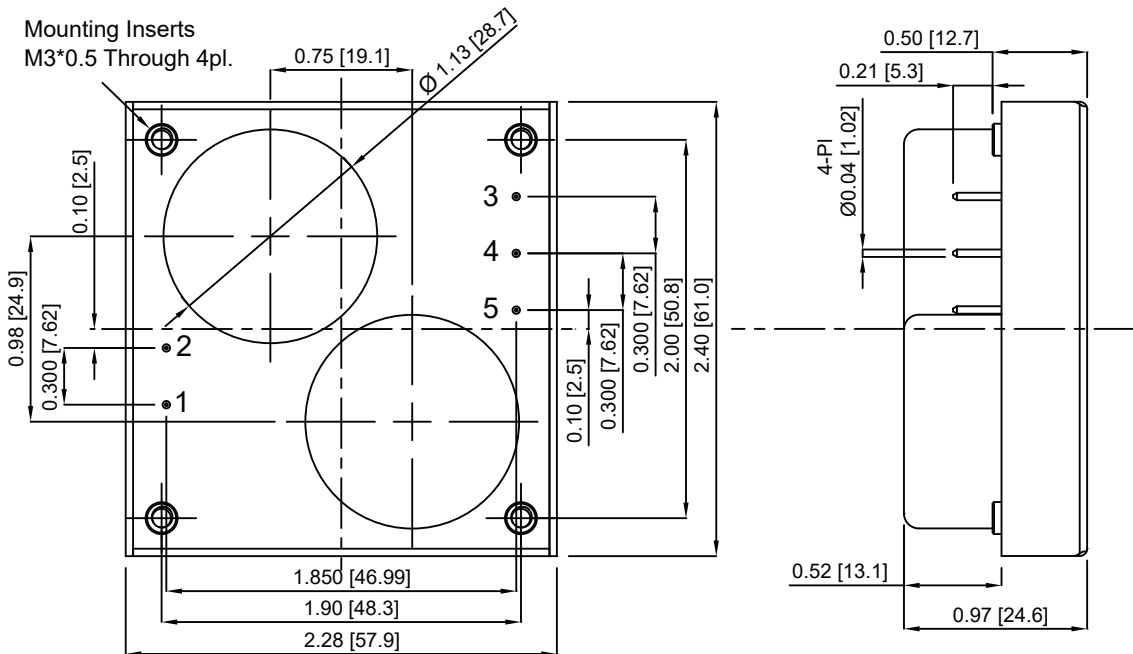

PIN CONNECTION	
PIN	Function
1	+V Input
2	-V Input
3	CASE
4	-V Output
5	+V Output

MODEL NUMBER	INPUT VOLTAGE	INPUT SURGE VOLTAGE	OUTPUT RATED CURRENT	DC RESISTANCE (+Vin to +Vo)	DC RESISTANCE (-Vin to -Vo)
FM10D200P	200 VDC max	250 VDC max	10 A max.	50 mΩ typ.	50 mΩ typ.

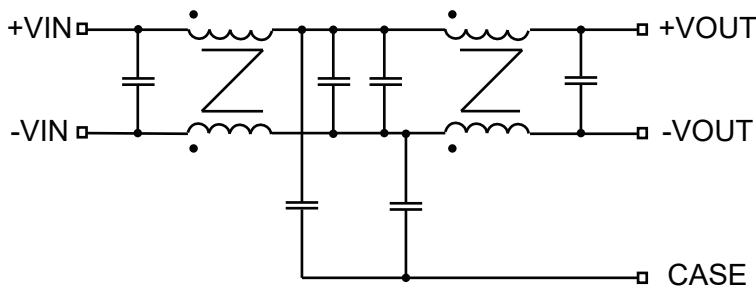
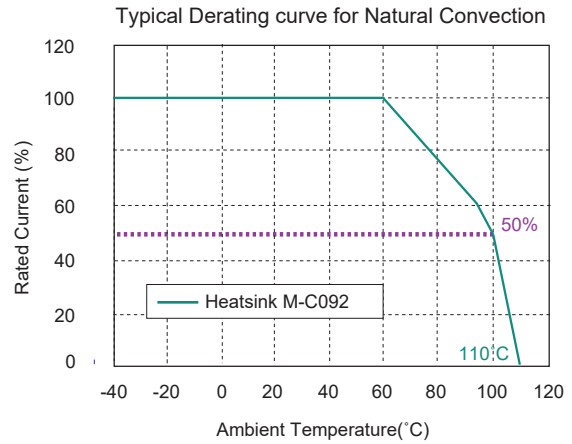
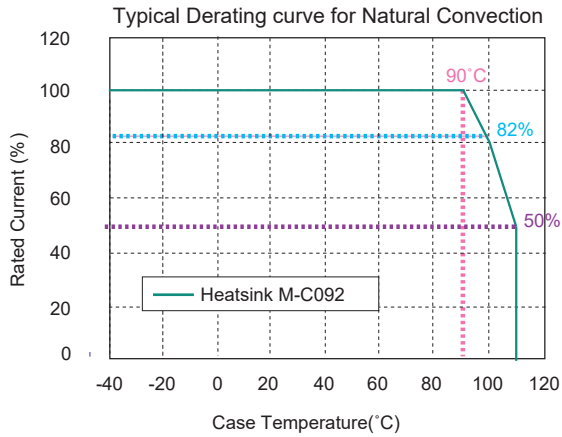

Figure1 Internal Schematic for FM10D200P Module

Derating Curve



Specifications

All Specifications Typical At Nominal Line, Full Load, and 25°C Unless Otherwise Noted

INPUT SPECIFICATIONS

Input Voltage Range	200Vdc max.
Input Surge Voltage	250Vdc/1s
Input Rated Current (note 1)	10A max

GENERAL SPECIFICATIONS

Isolation Voltage	Input/Case 3000Vdc min
Isolation Voltage	Output/Case 3000Vdc min.
Isolation Resistance	10 ⁸ ohm min.
DC Resistance	See Table
Operating Case Temperature Range (note1)	-40°C to +110°C
Storage Temperature Range	-55°C to +105°C
Dimensions	2.28x2.40x0.97 inches (57.9x 61x24.6 mm)
Case Material	Aluminum Case with Silicone Potting
Weight	128 g

NOTE

1. Maximum case temperature under any operating condition should refer derating curve

Common-mode Insertion Loss

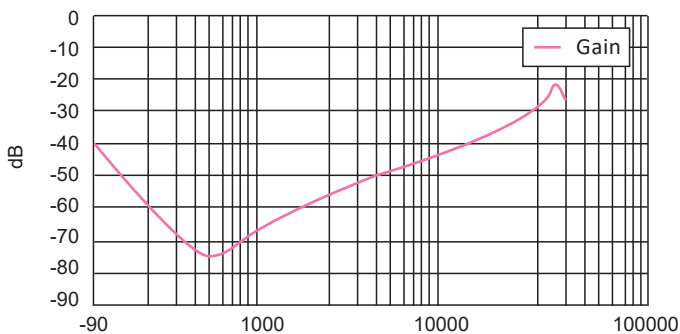

Differential-mode Insertion Loss

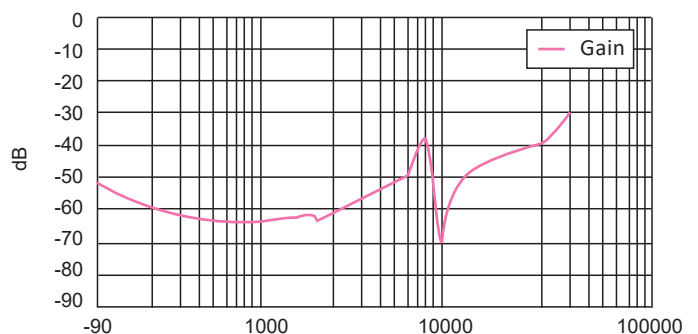

Typical Common-mode and Differential-mode Loss for FM10D200P

HEATSINK KIT for DC/DC CONVERTERS

Features

- ◆ Constructed of aluminum AL6063 for optimum heat transfer
- ◆ Designed specifically for DC/DC Converters and other baseplate packages
- ◆ Finished with black anodize plating
- ◆ Mounting hardware and thermal pad are available

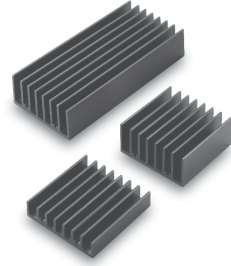

DC/DC PACKAGE	FIN STYLE	HEATSINK HEIGHT (mm)	PART NUMBER			THERMAL RESISTANCE (C/W)				
			HEATSINK	THERMAL PAD	MOUNTING HARDWARE	NATURAL CONVECTION	100 LFM	200 LFM	300 LFM	400 LFM
SB 1"x1"	Cross Cut	10.0	SBC100 (K-C087)	N/A ^7	CLIP HC01	12.5	--	--	--	--
B 2"x1"	Cross Cut	10.0	BC100 (K-C088)	N/A ^7	CLIP HC01	10.2	--	--	--	--
LB 2.05"x1.2"	Transverse	12.7	LBT127 (M-C655)	PL01	K258W (NOTES 5)	8.99	3.29	2.73	2.40	2.10
Quarter Brick	Longitudinal	12.7	QBL127 (M-C448)	PQ01	K308W (NOTES 5)	5.61	4.01	3.39	2.86	2.49
	Transverse	21	QBT210 (M-C421)			4.78	2.44	2.06	1.76	1.58
Half Brick	Longitudinal	21	HBL210 (M-C308)	PH01	K310W (NOTES 5)	3.9	1.74	1.33	1.12	0.97
	Transverse	12.7	HBT127 (M-C091)			4.7	2.89	2.3	1.88	1.59
	Transverse	25.4	HBT254 (M-C092)			3.0	1.44	1.17	1.04	0.95
Full Brick	Longitudinal	25.4	FBL254 (M-B012)	PF01	K320W (NOTES 5)	2.4	1.76	1.17	1.0	0.83
	Longitudinal	25.4	FBL254T ^1 (M-C997)			K320N (NOTES 5)	2.4	1.76	1.17	1.0

NOTES:

1. With threaded mounting hole
2. Example Part Numbers:
 QBL127: Quarter Brick Heatsink (12.7mm High), plate fin (longitudinal)
 FBL254PF01: Full Brick Heatsink (25.4mm High), plate fin (longitudinal) with thermal interface pad
 HBT127PH01K308W: Half Brick Heatsink (12.7mm High), plate fin (transverse) with thermal interface pad and 4 pieces of M3 x 8mm screws & spring washers
 HBL210K308W: Half Brick Heatsink (21.0mm High), plate fin (longitudinal) with 4 pieces of M3 x 8mm screws & spring washers
3. Thermal data provided are for reference only. Actual cooling performance may vary by application.
4. Specifications are subject to change without notice.
5. K258W: Screw set M2.5*8mm screw & lock washer x 2pcs K308W : Screw set M3*8mm screw with spring washer x 4pcs
 K310W: Screw set M3*10mm screw with spring washer x 4pcs K320W : Screw set M3*20mm screw & spring washer x 4pcs
 K320N: Screw set M3*20mm screw & lock screw nut x 4pcs
6. For volume orders, converters will be supplied with heat-sink already mounted. Separate heatsinks are only available for prototypes and small quantity orders.
7. Applying proper thermal paste is recommended.

Quarter Brick Heatsink

Heat Sink: QBT210 (M-C421) Transverse Fins
 Thermal Pad: PQ01 35.8*56.9*0.25 mm
 Screw Set: K308W SMP+SW M3*8mm
 All Dimensions in mm

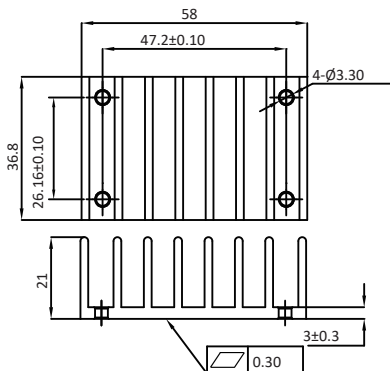

- Rca: 4.78°C/W (typ.), at natural convection
 2.44°C/W (typ.), at 100LFM
 2.06°C/W (typ.), at 200LFM
 1.76°C/W (typ.), at 300LFM
 1.58°C/W (typ.), at 400LFM

Heat Sink: QBL127 (M-C448) Longitudinal Fins
 Thermal Pad: PQ01 35.8*56.9*0.25 mm
 Screw Set: K308W SMP+SW M3*8mm
 All Dimensions in mm

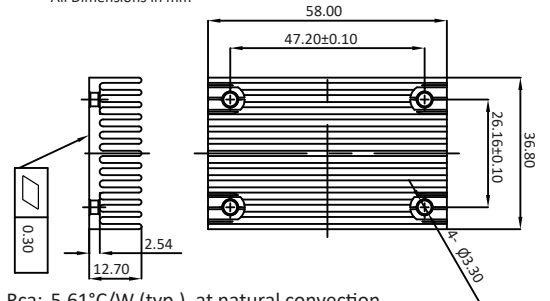

- Rca: 5.61°C/W (typ.), at natural convection
 4.01°C/W (typ.), at 100LFM
 3.39°C/W (typ.), at 200LFM
 2.86°C/W (typ.), at 300LFM
 2.49°C/W (typ.), at 400LFM

Full Brick Heatsink

Heat Sink: FBL254 (M-B012) Longitudinal Fins
Thermal Pad: PF01 60*115.8*0.25mm
Screw Set: K320N M3*20mm + Nut NH+WOM3*P0.5N
Clear Mounting Inserts Φ 3.3mm Through
All Dimensions in mm

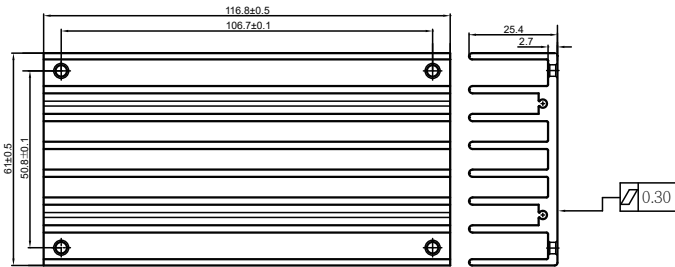

Rca: 2.4°C/W (typ.), at natural convection
1.76°C/W (typ.), at 100LFM,
1.17°C/W (typ.), at 200LFM
1.00°C/W (typ.), at 300LFM
0.83°C/W (typ.), at 400LFM

Heat Sink: FBL254T(M-C997) Longitudinal Fins
Thermal Pad: PF01 60*115.8*0.25
Screw Set: K320W M3*20mm+Washer WS3.2N
Mounting Inserts M3*0.5 Through
All Dimensions in mm

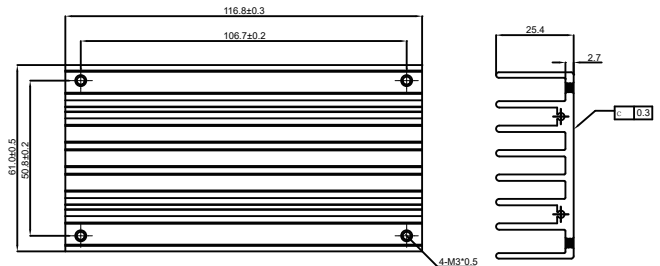

Half Brick Heatsink

Heat Sink: HBL210 (M-C308) Longitudinal Fins
Thermal Pad: PH01 56.9*60*0.25 mm
Screw Set: K308W SMP+SW M3*8mm
All Dimensions in mm

Rca:
3.9°C/W (typ.), at natural convection
1.74°C/W (typ.), at 100LFM
1.33°C/W (typ.), at 200LFM
1.12°C/W (typ.), at 300LFM
0.97°C/W (typ.), at 400LFM

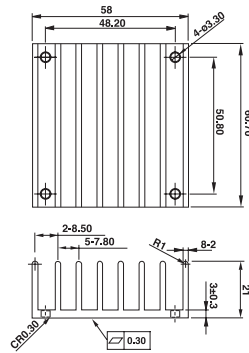

SB CASE Heatsink

Heat Sink: SBC100
Clip: HC01
All Dimensions in mm

Rca:
12.5°C/W (typ.), at natural convection

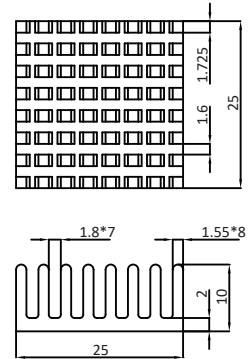

Heat Sink: HBT127 (M-C091) Transverse Fins
Thermal Pad: PH01 56.9*60*0.25 mm
Screw Set: K308W SMP+SW M3*8mm
All Dimensions in mm

Rca:
4.7°C/W (typ.), at natural convection
2.89°C/W (typ.), at 100LFM
2.30°C/W (typ.), at 200LFM
1.88°C/W (typ.), at 300LFM
1.59°C/W (typ.), at 400LFM

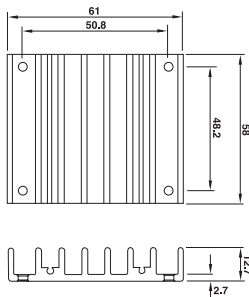

B CASE Heatsink

Heat Sink: BC100
Clip: HC01
All Dimensions in mm

Rca:
10.2°C/W (typ.), at natural convection

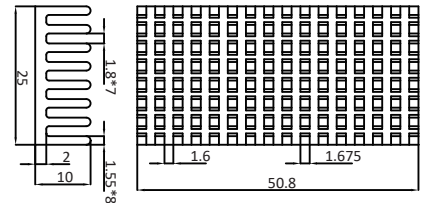

Heat Sink: HBT254 (M-C092) Transverse Fins
Thermal Pad: PH01 56.9*60*0.25 mm
Screw Set: K308W SMP+SW M3*8mm
All Dimensions in mm

Rca:
3°C/W (typ.), at natural convection
1.44°C/W (typ.), at 100LFM
1.17°C/W (typ.), at 200LFM
1.04°C/W (typ.), at 300LFM
0.95°C/W (typ.), at 400LFM

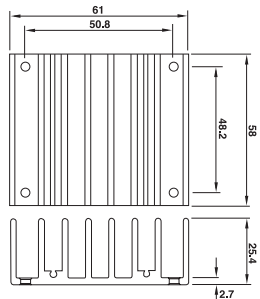

LB CASE Heatsink

Heat Sink: LBT127 (M-C655) Transverse Fins
Thermal Pad: PL01 29.5*49.8*0.25mm
Screw Set: K258W M2.5*8mm+Lock Washer
All Dimensions in mm

Rca:
8.99°C/W (typ.), at natural convection
3.29°C/W (typ.), at 100LFM
2.73°C/W (typ.), at 200LFM
2.40°C/W (typ.), at 300LFM
2.10°C/W (typ.), at 400LFM

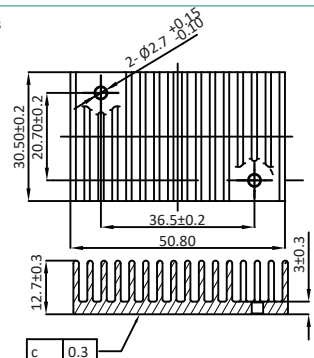

SIPSMT05-05 SERIES

5 AMP, POL CONVERTERS

Features

- ◆ Non-Isolated POL Converter
- ◆ SIP / SMT Package
- ◆ Output Current 5AMP
- ◆ Input Voltage Range 3.0-5.5VDC
- ◆ Output Voltage Range 0.75-3.63VDC
- ◆ High Efficiency to 94%
- ◆ Over Temperature Protection
- ◆ Continuous Short Circuit Protection
- ◆ Remote On/Off
- ◆ UL/C-UL60950 Certified

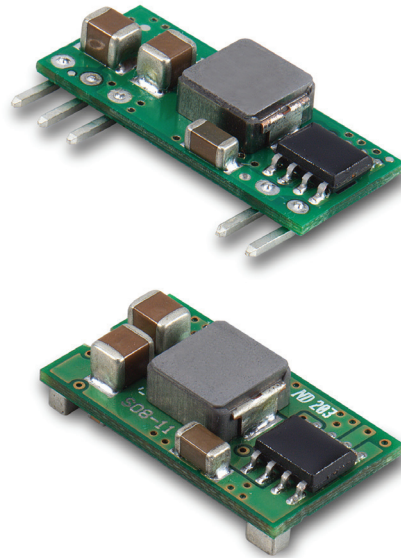

Mechanical Dimensions

Mechanical Specification

All Dimensions In Inches (mm)

Tolerances Inches: X.XX= ±0.02 , X.XXX= ±0.010
 Millimeters: X.X= ±0.5 , X.XX=±0.25

SIP Packages

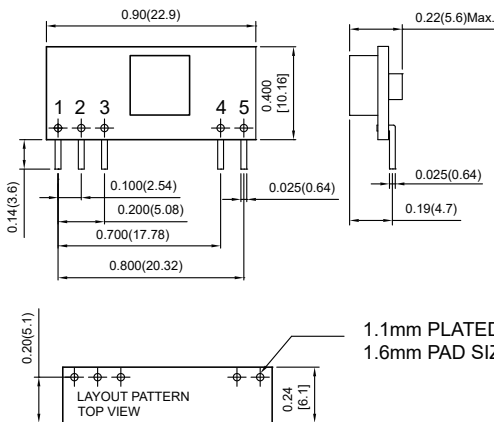

PIN CONNECTION	
PIN	Function
1	+Output
2	Trim
3	Common
4	+V Input
5	On/Off

SMT Packages

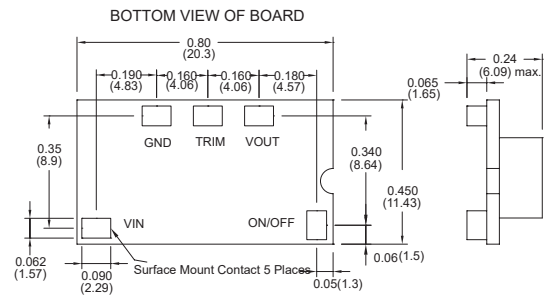

MODEL NUMBER	INPUT VOLTAGE	OUTPUT VOLTAGE	OUTPUT CURRENT	INPUT CURRENT		Efficiency (%)
				NO LOAD	FULL LOAD	
SIP05-05S33A	3.0-5.5 VDC	0.75 VDC	5 A	25 mA	949 mA	79
	3.0-5.5 VDC	1.2 VDC	5 A	30 mA	1412 mA	85
	3.0-5.5 VDC	1.5 VDC	5 A	30 mA	1724 mA	87
	3.0-5.5 VDC	1.8 VDC	5 A	35 mA	2022 mA	89
SMT05-05S33A	3.0-5.5 VDC	2.0 VDC	5 A	35 mA	2222 mA	90
	3.0-5.5 VDC	2.5 VDC	5 A	35 mA	2217 mA	92
	4.5-5.5 VDC	3.3 VDC	5 A	35 mA	3511 mA	94

NOTE: Nominal Input Voltage 5.0VDC

Derating Curve

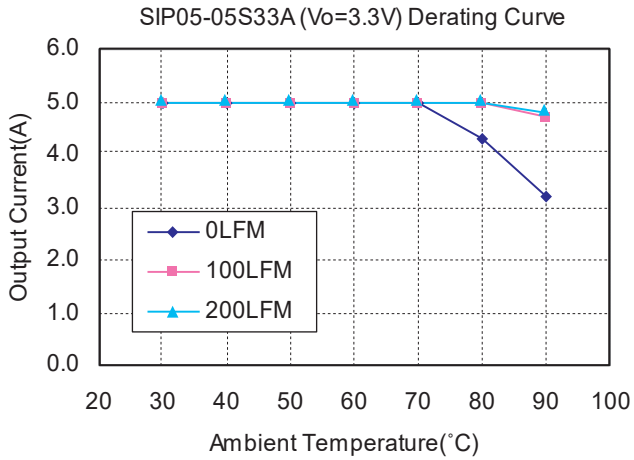

Figure2. Typical Power De-rating for 5V IN 3.3Vout

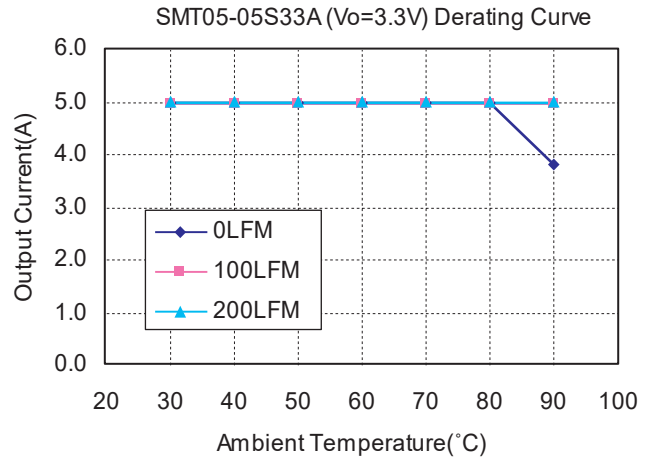

Figure3. Typical Power De-rating for 5V IN 3.3Vout

Specifications

All Specifications Typical At Nominal Line, Full Load, and 25°C Unless Otherwise Noted

INPUT SPECIFICATIONS

Input Voltage Range	$V_o, set \leq V_{in} - 0.5VDC$
Under Voltage Lock-out	5V 3.0 – 5.5V Power up 2.0V typ. Power down 1.9V typ.
Input Filter Type	Capacitive
Positive Remote On/Off Control:	
Module On	Open Circuit or = V_{in}
Module Off	< 0.4Vdc

OUTPUT SPECIFICATIONS

Voltage Accuracy	±1.5% max.
Transient Response: 50% Step Load Change	< 200µs
Ripple and Noise, 20MHz BW (note 3)	20mVrms max. 50mVpk-pk max.
Temperature Coefficient	±0.03%/°C max.
Short Circuit Protection	Continuous
Line Regulation (note 1)	±0.4% max.
Load Regulation (note 2)	±0.5% max.
Capacitive Load Low ESR	3000µF max.
External Trim Adj. Range (see Table 1)	$V_o = 0.75 - 3.63Vdc$
Start up time	6.5ms typ.

GENERAL SPECIFICATIONS

Efficiency	See Table
Isolation Voltage	Non-isolation
Switching Frequency	300KHz typ.
Over Temperature Protection	120°C typ.
Operating Ambient Temperature Range	-40°C to +85°C
Power Derating Curve	see Figure2, 3
Storage Temperature Range	-55°C to +125°C
MTBF MIL-STD-217F, GB, 25°C, Full Load	1.5Mhrs typ.
Dimensions:	SIP Package: 0.90 x 0.400 x 0.22 inches (22.9 x 10.16 x 5.6 mm) SMT Package: 0.80 x 0.450 x 0.24 inches (20.3 x 11.43 x 6.09 mm)

Structure
Weight

Non-potted With Open Frame Type
2.3 g

NOTE

1. Measured from high line to low line, $V_o, set = 1.8VDC$.
2. Measured from full load to zero load, $V_o, set = 3.3VDC$.
3. The output noise is measured with 10µf tantalum capacitor and 1µf ceramic capacitor across output.
4. The input terminal recommend to parallel with 100µF capacitor ESR< 100mΩ to reduce the input ripple voltage.
5. Suffix "N" to the model number with negative logic remote On/Off
Model On open circuit or < 0.4VDC
Module Off > +2.8VDC to V_{in}

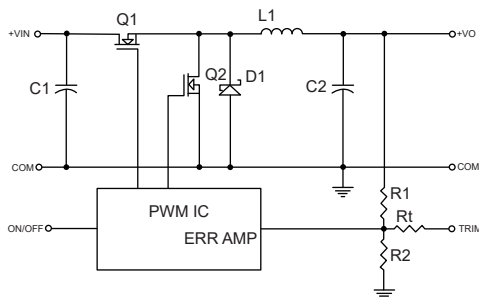

Figure 1. Simplified Schematic

$V_o, set (V)$	$R_{trim} (K^{\circ})$
0.75	Open
1.2	41.71
1.5	22.98
1.8	14.96
2.0	11.75
2.5	3.93
3.3	3.15
3.63	2.20

Table 1. External Resistor Values for programming out voltage

SIPSMT05-12 SERIES

5 AMP, POL CONVERTERS

Features

- ◆ Non-isolated POL Converter
- ◆ SIP / SMT Package
- ◆ Output Current 5AMP
- ◆ Input Voltage Range 8.3-14VDC
- ◆ Output Voltage Range 0.75-5VDC
- ◆ High Efficiency to 92%
- ◆ Over Temperature Protection
- ◆ Continuous Short Circuit Protection
- ◆ Remote ON/OFF Control
- ◆ UL/C-UL60950 Certified

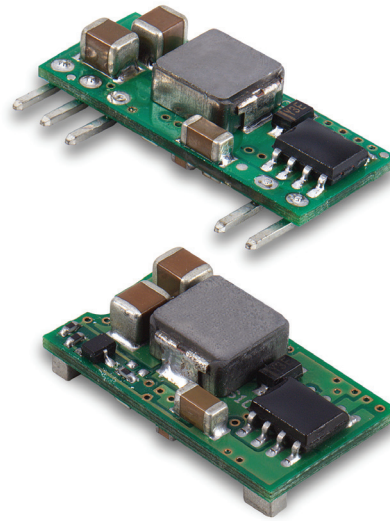

Mechanical Dimensions

Mechanical Specification

All Dimensions In Inches (mm)

Tolerances Inches: X.XX= ±0.02 , X.XXX= ±0.010

Millimeters: X.X= ±0.5 , X.XX=±0.25

SIP Packages

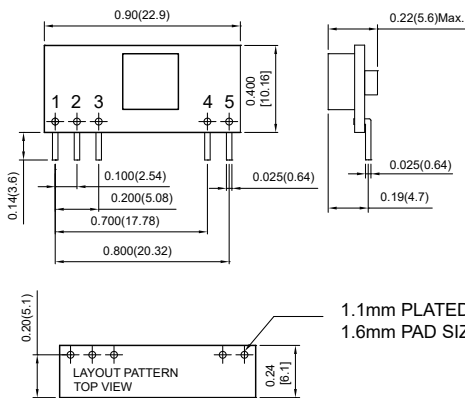

SMT Packages

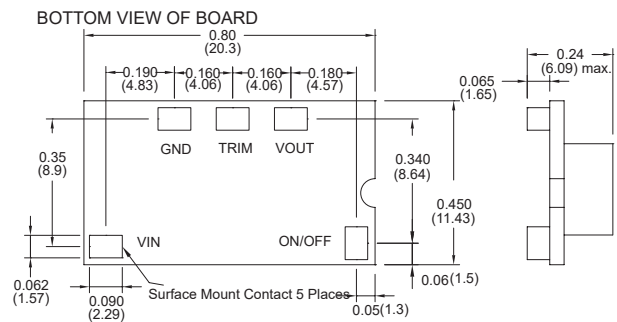

MODEL NUMBER	INPUT VOLTAGE	OUTPUT VOLTAGE	OUTPUT CURRENT	INPUT CURRENT		Efficiency (%)
				NO LOAD	FULL LOAD	
SIP05-12S05A	8.3-14 VDC	0.75 VDC	5 A	20 mA	428 mA	73
	8.3-14 VDC	1.2 VDC	5 A	25 mA	625 mA	80
	8.3-14 VDC	1.5 VDC	5 A	25 mA	762 mA	82
	8.3-14 VDC	1.8 VDC	5 A	30 mA	893 mA	84
SMT05-12S05A	8.3-14 VDC	2.0 VDC	5 A	30 mA	980 mA	85
	8.3-14 VDC	2.5 VDC	5 A	35 mA	1197 mA	87
	8.3-14 VDC	3.3 VDC	5 A	45 mA	1545 mA	89
	8.3-14 VDC	5.0 VDC	5 A	50 mA	2264 mA	92
	8.3-14 VDC	5.0 VDC	5 A	50 mA	2264 mA	92

NOTE: Nominal Input Voltage 12VDC

Derating Curve

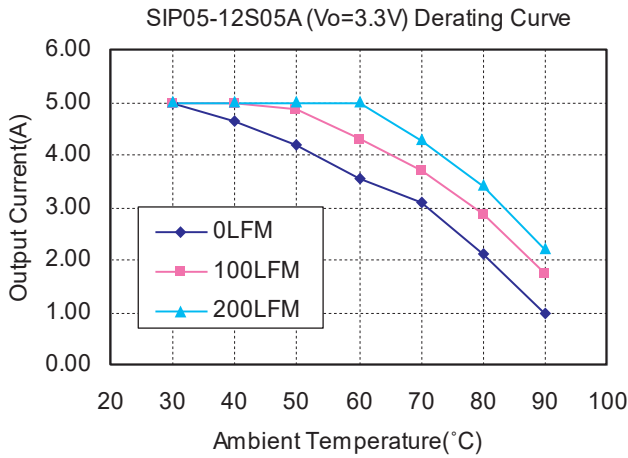

Figure2. Typical Power De-rating for 12V IN 3.3Vout

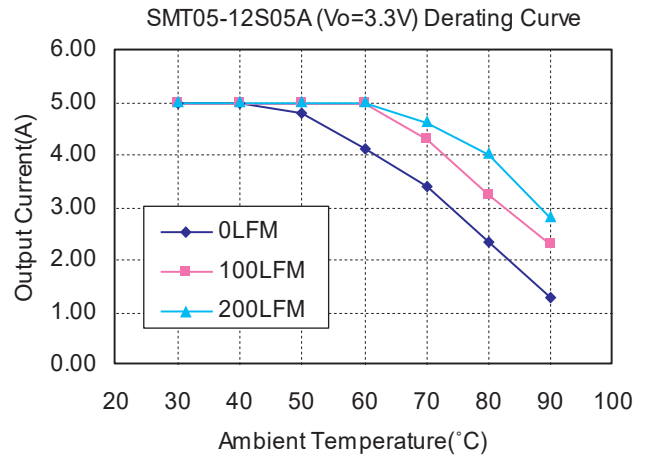

Figure3. Typical Power De-rating for 12V IN 3.3Vout

Specifications

All Specifications Typical At Nominal Line, Full Load, and 25°C Unless Otherwise Noted

INPUT SPECIFICATIONS

Input Voltage Range	12V	8.3-14V
Under Voltage Lock-out	Power up	8.0V typ.
	Power down	7.9V typ.
Input Filter Type		Capacitive
Positive Remote On/Off Control:		
Module On	Open Circuit or = Vin	
Module Off	<0.4Vdc	

OUTPUT SPECIFICATIONS

Voltage Accuracy	±1.5% max.	
Transient Response: 50% Step Load Change	< 200µs	
Ripple and Noise, 20MHz BW (note 3)	20mVrms, 50mVpk-pk max.	
	Vo=5Vdc	45mVrms,
		75mVpk-pk max.
Temperature Coefficient	±0.03%/°C max.	
Short Circuit Protection	Continuous	
Line Regulation (note 1)	±0.2% max.	
Load Regulation (note 2)	±0.5% max.	
Capacitive Load Low ESR	3000µF max.	
External Trim Adj. Range (see Table1)	Vo=0.75-5.0Vdc	
Start up time	7ms typ.	

GENERAL SPECIFICATIONS

Efficiency	See Table
Isolation Voltage	Non-isolation
Switching Frequency	300KHz typ.
Over Temperature Protection	120°C typ.
Operating Ambient Temperature Range	-40°C to +85°C
Power De-rating Curve	see Figure2, 3
Storage Temperature Range	-55°C to +125°C
MTBF	MIL-STD-217F, GB, 25°C, Full Load
Dimensions:	1.5Mhrs typ.
	SIP Package: 0.90 x 0.400 x 0.22 inches
	(22.9 x 10.16 x 5.6 mm)
	SMT Package: 0.80 x 0.450 x 0.24 inches
	(20.3 x 11.43 x 6.09 mm)
Structure	Non-potted With Open Frame Type
Weight	2.3 g

NOTE

1. Measured from high line to low line, Vo, set=1.8VDC.
2. Measured from full load to zero load, Vo, set=3.3VDC.
3. The output noise is measured with 10µF tantalum capacitor and 1µF ceramic capacitor across output.
4. The input terminal recommend to parallel with 100µF capacitor ESR< 100mΩ to reduce the input ripple voltage
5. Suffix "N" to the model number with negative logic remote On/Off
 Model On open circuit or < 0.4VDC
 Module Off >+2.8VDC to Vin

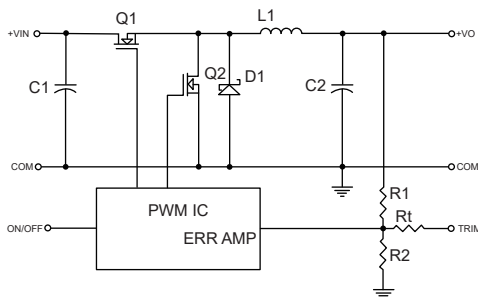

Figure 1.Simplified Schematic

Vo,set(V)	Rtrim (K ^Ω)
0.75	Open
1.2	22.33
1.5	13.0
1.8	9.0
2.0	7.4
2.5	5.6
3.2	3.12
5.0	1.47

Table 1.External Resistor Values for programming out voltage

SIPSMT10-05 SERIES

10 AMP, POL CONVERTERS

Features

- ◆ Non-isolated POL converter
- ◆ SIP / SMT Package
- ◆ Output Current 10AMP
- ◆ Input Voltage Range 3-5.5VDC
- ◆ 300KHz Switching Frequency
- ◆ High Efficiency to 95%
- ◆ Over Temperature Protection
- ◆ Continuous Short Circuit Protection
- ◆ Remote On/Off Control
- ◆ UL/C-UL60950 Certified

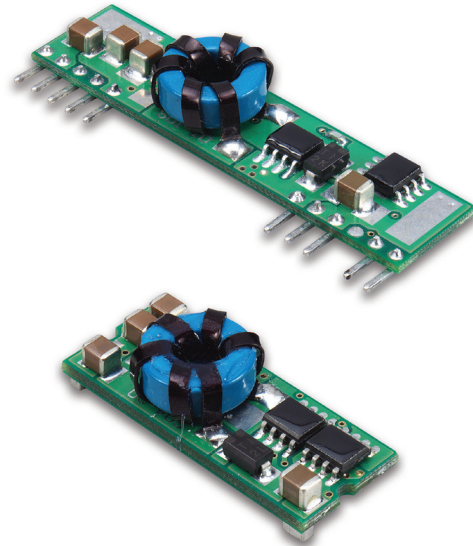

Mechanical Dimensions

Mechanical Specification
 All Dimensions In Inches (mm)
 Tolerances Inches: X.XX= ±0.02 , X.XXX= ±0.010
 Millimeters: X.X= ±0.5 , X.XX=±0.25

SIP Packages

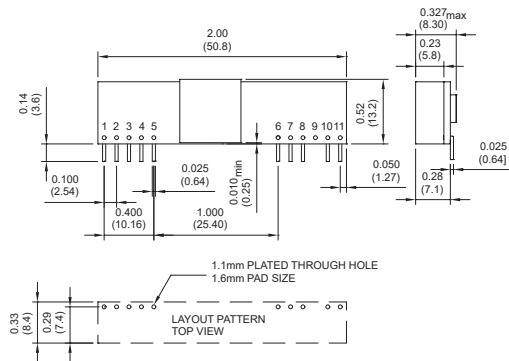

PIN CONNECTION	
PIN	Function
1	+Output
2	+Output
3	+Sense
4	+Output
5	Common
6	Common
7	+V Input
8	+V Input
9	No Pin
10	Trim
11	On/Off Control

SMT Packages

Bottom View of Board

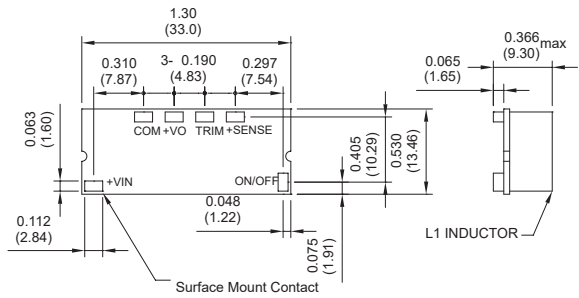

MODEL NUMBER	INPUT VOLTAGE	OUTPUT VOLTAGE	OUTPUT CURRENT	INPUT CURRENT		Efficiency (%)
				NO LOAD	FULL LOAD	
SIP10-05S10	3.0-5.5 VDC	1.0 VDC	10 A	50 mA	2353 mA	85
SMT10-05S10	3.0-5.5 VDC	1.0 VDC	10 A	50 mA	2353 mA	85
SIP10-05S12	3.0-5.5 VDC	1.2 VDC	10 A	50 mA	2791 mA	86
SMT10-05S12	3.0-5.5 VDC	1.2 VDC	10 A	50 mA	2791 mA	86
SIP10-05S15	3.0-5.5 VDC	1.5 VDC	10 A	50 mA	3409 mA	88
SMT10-05S15	3.0-5.5 VDC	1.5 VDC	10 A	50 mA	3409 mA	88
SIP10-05S18	3.0-5.5 VDC	1.8 VDC	10 A	50 mA	4000 mA	90
SMT10-05S18	3.0-5.5 VDC	1.8 VDC	10 A	50 mA	4000 mA	90
SIP10-05S20	3.0-5.5 VDC	2.0 VDC	10 A	60 mA	4396 mA	91
SMT10-05S20	3.0-5.5 VDC	2.0 VDC	10 A	60 mA	4396 mA	91
SIP10-05S25	3.0-5.5 VDC	2.5 VDC	10 A	60 mA	5376 mA	93
SMT10-05S25	3.0-5.5 VDC	2.5 VDC	10 A	60 mA	5376 mA	93
SIP10-05S33	4.5-5.5 VDC	3.3 VDC	10 A	60 mA	6947 mA	95
SMT10-05S33	4.5-5.5 VDC	3.3 VDC	10 A	60 mA	6947 mA	95

NOTE: Nominal Input Voltage 5.0VDC

Derating Curve

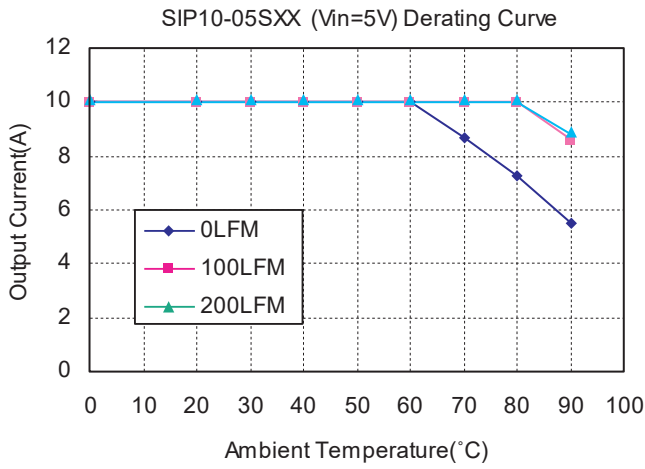

Figure2. Typical Power De-rating for 5Vin

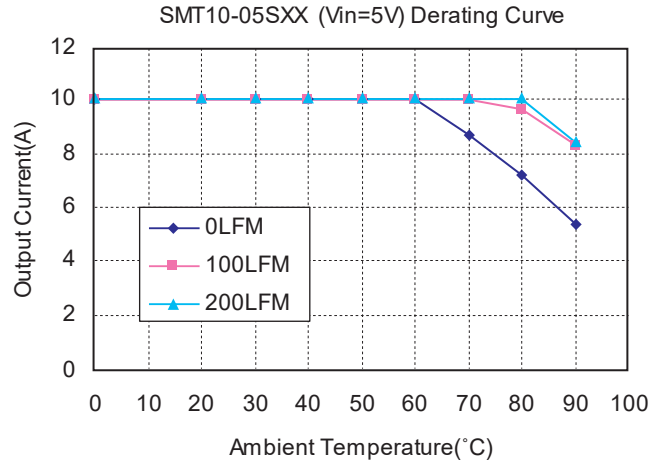

Figure3. Typical Power De-rating for 5Vin

Specifications

All Specifications Typical At Nominal Line, Full Load, and 25°C Unless Otherwise Noted

INPUT SPECIFICATIONS

Input Voltage Range	5V 3.0-5.5V
	5V 4.5-5.5V
Under Voltage Lock-out	Power up 2.8V typ.
	Power down 2.7V typ.
Input Filter Type	Capacitive
Positive Remote On/Off Control:	
Module On	Open Circuit or = Vin
Module Off	0 to <0.4Vdc

OUTPUT SPECIFICATIONS

Voltage Accuracy	±1.5% max.
Transient Response: 25% Step Load Change	< 200µs
Ripple and Noise, 20MHz BW (note3)	20mVrms max.
	50mVpk-pk max.
Temperature Coefficient	±0.03%/°C max.
Short Circuit Protection	Continuous
Line Regulation (note1)	±0.2% max.
Load Regulation (note2)	±0.5% max.
Capacitive Load, Low ESR	10000µF max.
External Trim Adj. Range	±10%
Start up time	4.5ms typ.

GENERAL SPECIFICATIONS

Efficiency	See Table
Isolation Voltage	Non-isolation
Switching Frequency	300KHz typ.
Over Temperature Protection	120°C typ.
Operating Ambient Temperature Range	-40°C to +85°C
Power Derating Curve	see Figure2, 3
Storage Temperature Range	-55°C to +125°C
MTBF MIL-STD-217F, GB, 25°C, Full Load	1.5Mhrs typ.
Dimensions:	
	SIP Package: 2.00 x 0.327 x 0.52 inches (50.8 x 8.3 x 13.2 mm)
	SMT Package: 1.30 x 0.530 x 0.366 inches (33.0x12.46x9.3 mm)
Structure	Non-potted With Open Frame Type
Weight	6.8 g

NOTE

1. Measured from high line to low line.
2. Measured from full load to zero load.
3. The output noise is measured with 10µf tantalum capacitor and 1µf ceramic capacitor across output.
4. The input terminal recommend to parallel with 100µF capacitor ESR< 20mΩ to reduce the input ripple voltage.
5. Suffix "N" to the model number with negative logic remote On/Off
 Model On open circuit or < 0.4VDC
 Module Off >+2.8VDC to Vin

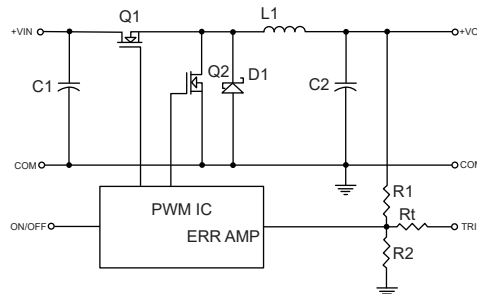

Figure 1. Simplified Schematic

SIPSMT10-12 SERIES

10 AMP, POL CONVERTERS

Features

- ◆ Non-Isolated POL Converter
- ◆ SIP / SMT Package
- ◆ Output Current 10AMP
- ◆ Input Voltage Range 9.0-14VDC
- ◆ 300KHz Switching Frequency
- ◆ High Efficiency to 95%
- ◆ Over Temperature Protection
- ◆ Continuous Short Circuit Protection
- ◆ Remote ON/OFF Control
- ◆ UL/C-UL60950 Certified

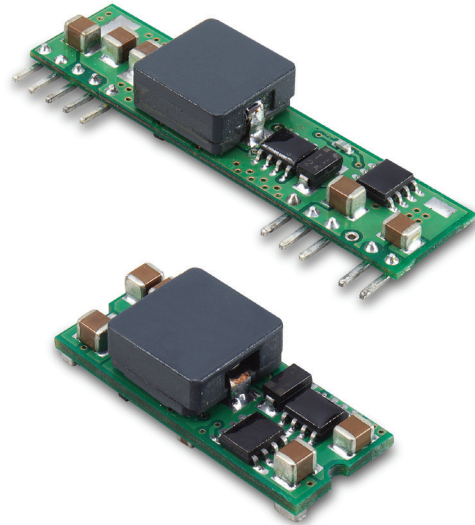

Mechanical Dimensions

Mechanical Specification

All Dimensions In Inches (mm)

Tolerances Inches: X.XX= ±0.02 , X.XXX= ±0.010
 Millimeters: X.X= ±0.5 , X.XX=±0.25

SIP Packages

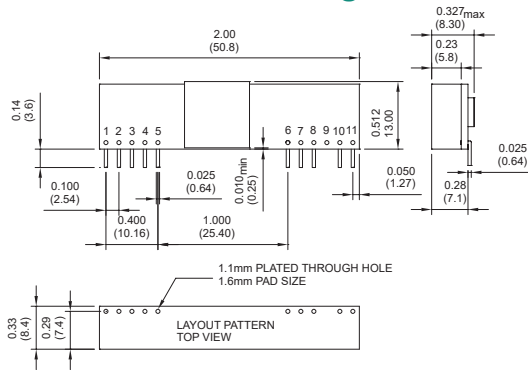

PIN CONNECTION	
PIN	Function
1	+Output
2	+Output
3	+Sense
4	+Output
5	Common
6	Common
7	+V Input
8	+V Input
9	No Pin
10	Trim
11	On/Off Control

SMT Packages

Bottom View of Board

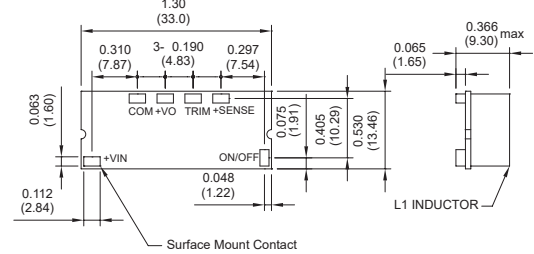

MODEL NUMBER	INPUT VOLTAGE	OUTPUT VOLTAGE	OUTPUT CURRENT	INPUT CURRENT		Efficiency (%)
				NO LOAD	FULL LOAD	
SIP10-12S10	9.0-14 VDC	1.0 VDC	10 A	50 mA	992 mA	84
SMT10-12S10	9.0-14 VDC	1.0 VDC	10 A	50 mA	992 mA	84
SIP10-12S12	9.0-14 VDC	1.2 VDC	10 A	50 mA	1163 mA	86
SMT10-12S12	9.0-14 VDC	1.2 VDC	10 A	50 mA	1163 mA	86
SIP10-12S15	9.0-14 VDC	1.5 VDC	10 A	50 mA	1404 mA	89
SMT10-12S15	9.0-14 VDC	1.5 VDC	10 A	50 mA	1404 mA	89
SIP10-12S18	9.0-14 VDC	1.8 VDC	10 A	60 mA	1666 mA	90
SMT10-12S18	9.0-14 VDC	1.8 VDC	10 A	60 mA	1666 mA	90
SIP10-12S20	9.0-14 VDC	2.0 VDC	10 A	60 mA	1832 mA	91
SMT10-12S20	9.0-14 VDC	2.0 VDC	10 A	60 mA	1832 mA	91
SIP10-12S25	9.0-14 VDC	2.5 VDC	10 A	60 mA	2264 mA	92
SMT10-12S25	9.0-14 VDC	2.5 VDC	10 A	60 mA	2264 mA	92
SIP10-12S33	9.0-14 VDC	3.3 VDC	10 A	70 mA	2956 mA	93
SMT10-12S33	9.0-14 VDC	3.3 VDC	10 A	70 mA	2956 mA	93
SIP10-12S05	9.0-14 VDC	5.0 VDC	10 A	70 mA	4385 mA	95
SMT10-12S05	9.0-14 VDC	5.0 VDC	10 A	70 mA	4385 mA	95
SIP10-12S05A	8.3-14 VDC	0.75-5 VDC	10 A	70 mA	2956 mA	93%@3.3V
SMT10-12S05A	8.3-14 VDC	0.75-5 VDC	10 A	70 mA	2956 mA	93%@3.3V

NOTE: Nominal Input Voltage 12VDC

Derating Curve

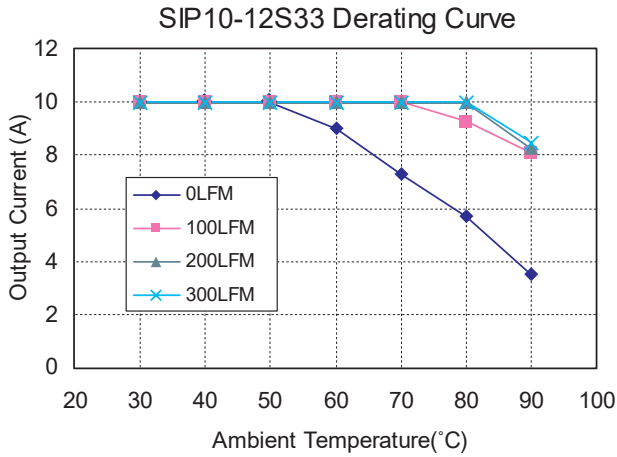

Figure2. Typical Power De-rating for 12Vin

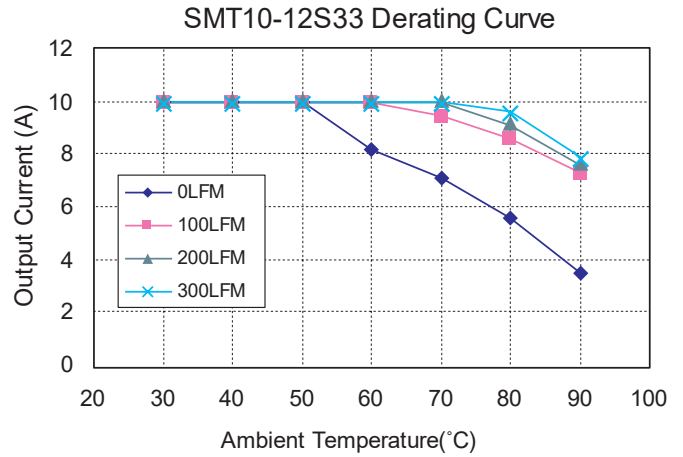

Figure3. Typical Power De-rating for 12Vin

Specifications

All Specifications Typical At Nominal Line, Full Load, and 25°C Unless Otherwise Noted

INPUT SPECIFICATIONS

Input Voltage Range	12V 9.0 – 14V
	12V 8.3 – 14V
Under Voltage Lock-out	Power up 8.0V typ.
	Power down 7.7V typ.
Input Filter Type	Capacitive
Positive Remote On/Off Control:	
Module On	Open Circuit or =Vin
Module Off	< 0.4Vdc

OUTPUT SPECIFICATIONS

Voltage Accuracy	±1.5% max.
Transient Response: 25% Step Load Change	< 200µs
Ripple and Noise, 20MHz BW (note 3)	20mVrms max.
	50mVpk-pk max.
Temperature Coefficient	±0.03%/°C max.
Short Circuit Protection	Continuous
Line Regulation (note 1)	±0.2% max.
Load Regulation (note 2)	±0.5% max.
Capacitive Load Low ESR	8000µF max.
External Trim Adj. Range	±10%
(SIP/SMT10-12S05)	+5%, -10%
(SIP/SMT10-12S05A)	0.75V-5.0V
Start up time	7ms typ.

GENERAL SPECIFICATIONS

Efficiency	See Table
Isolation Voltage	Non-isolation
Switching Frequency	300KHz typ.
Over Temperature Protection	120°C typ.
Operating Ambient Temperature Range	-40°C to +85°C
Power Derating Curve	see Figure2, 3
Storage Temperature Range	-55°C to +125°C
MTBF MIL-STD-217F, GB, 25°C, Full Load	0.98Mhrs typ.
Dimensions:	
	SIP Package: 2.00 x 0.512 x 0.327inches
	(50.8 x 13.00 x 8.30 mm)
	SMT Package: 1.30 x 0.530 x 0.366 inches
	(33.0 x 13.46 x 9.30 mm)
Structure	Non-potted With Open Frame Type
Weight	10 g

NOTE

1. Measured from high line to low line.
2. Measured from full load to zero load.
3. The output noise is measured with 10µf tantalum capacitor and 1µf ceramic capacitor across output.
4. The input terminal recommend to parallel with 100µF capacitor ESR< 100mΩ to reduce the input ripple voltage.
5. Suffix "N" to the model number with negative logic remote On/Off
 Model On open circuit or < 0.4VDC
 Module Off >+2.8VDC to Vin

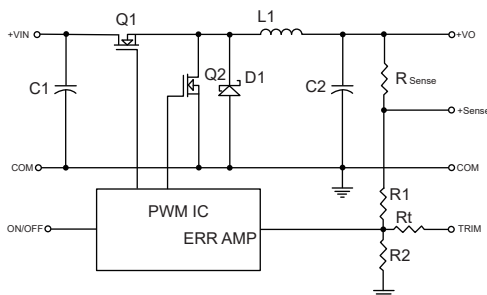

Figure 1. Simplified Schematic

Vo,set(V)	Rtrim (K ⁻¹)
0.7525	Open
1.2	22.46
1.5	13.05
1.8	9.024
2.0	7.417
2.5	5.009
3.3	3.122
5.0	1.472

Table 1. External Resistor Values for programming out voltage

SIPSMT10W-12 SERIES

10 AMP, POL CONVERTERS

Features

- ◆ Non-Isolated POL Converter
- ◆ SIP / SMT Package
- ◆ Output Current 10AMP
- ◆ Input Voltage Range 6.0-14VDC
- ◆ Output Voltage Range 0.7525-5VDC
- ◆ 300KHz Switching Frequency
- ◆ High Efficiency to 95%
- ◆ Over Temperature Protection
- ◆ Continuous Short Circuit Protection
- ◆ Remote ON/OFF Control
- ◆ Output Voltage Sequencing
- ◆ Power Good Signal
- ◆ UL/C-UL60950 Certified

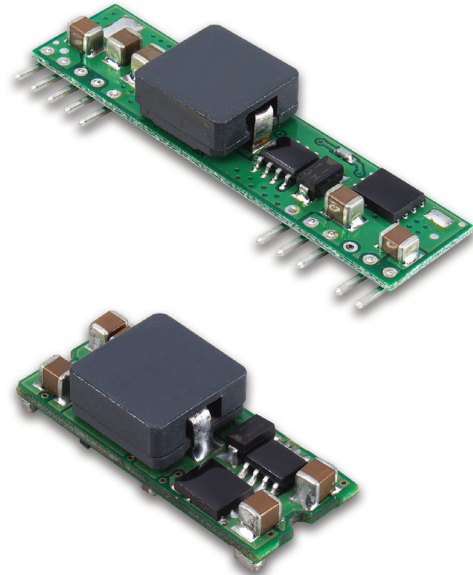

Mechanical Dimensions

Mechanical Specification

All Dimensions In Inches (mm)

Tolerances Inches: X.XX= ±0.02 , X.XXX= ±0.010
 Millimeters: X.X= ±0.5 , X.XX=±0.25

SIP Packages

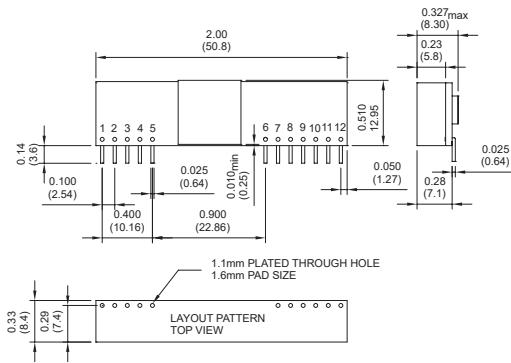

PIN CONNECTION	
PIN	Function
1	+Output
2	+Output
3	+Sense
4	+Output
5	Common
6	NO Pin/PGOOD
7	Common
8	+V Input
9	+V Input
10	Sequency
11	Trim
12	On/Off Control

SMT Packages

Bottom View of Board

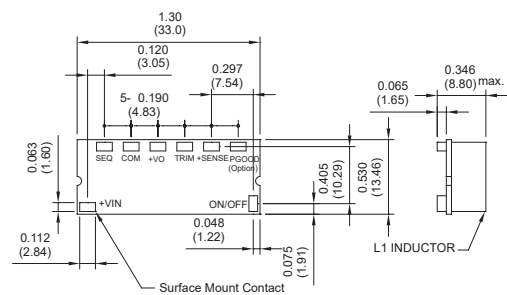

MODEL NUMBER	INPUT VOLTAGE	OUTPUT VOLTAGE	OUTPUT CURRENT	INPUT CURRENT		Efficiency (%)
				NO LOAD	FULL LOAD	
SIP10W-12S05A	6.0-14 VDC	0.7525 VDC	10 A	40 mA	762 mA	82
	6.0-14 VDC	1.2 VDC	10 A	40 mA	1149 mA	87
	6.0-14 VDC	1.5 VDC	10 A	50 mA	1404 mA	89
SMT10W-12S05A	6.0-14 VDC	1.8 VDC	10 A	50 mA	1666 mA	90
	6.0-14 VDC	2.0 VDC	10 A	60 mA	1832 mA	91
	6.0-14 VDC	2.5 VDC	10 A	65 mA	2264 mA	92
	6.0-14 VDC	3.3 VDC	10 A	75 mA	2956 mA	93
	6.5-14 VDC	5.0 VDC	10 A	95 mA	4386 mA	95

Derating Curve

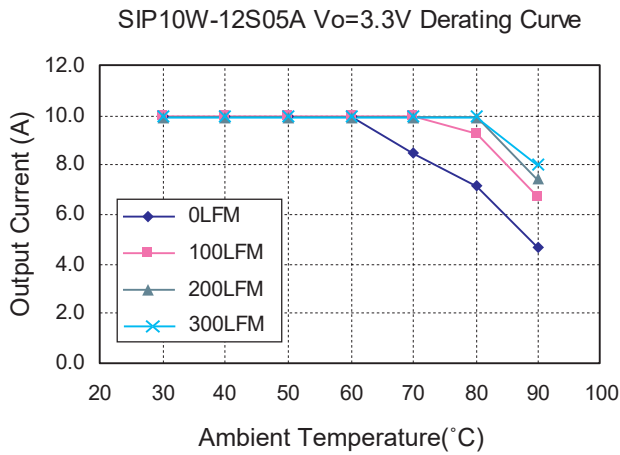

Figure2. Typical Power De-rating for 12Vin

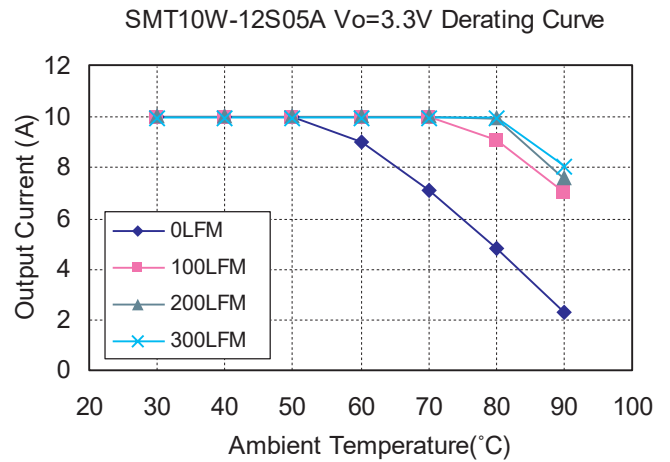

Figure3. Typical Power De-rating for 12Vin

Specifications

All Specifications Typical At Nominal Line, Full Load, and 25°C Unless Otherwise Noted

INPUT SPECIFICATIONS

Input Voltage Range	12V 6.0-14.0V
	12V 6.5-14.0V
Under Voltage Lock-out	Power up 5.0V typ.
	Power down 4.0V typ.
Input Filter Type	Capacitive
Positive Remote On/Off Control :	
Module On	Open Circuit or = Vin
Module Off	< 0.4 Vdc

OUTPUT SPECIFICATIONS

Voltage Accuracy	±1.5% max.
Transient Response: 25% Step Load Change	< 200µs
Ripple and Noise, 20MHz BW (note 3)	30mV rms max.
75mV pk-pk max.	
Temperature Coefficient	±0.03%/°C max.
Short Circuit Protection	Continuous
Line Regulation (note 1)	±0.2% max.
Load Regulation (note 2)	±0.5% max.
External Trim Adj. Range (see Table1)	Vo=0.75-5.0Vdc
Sequencing Slew Rate Capability (dVSEQ/dt)	0.1-1.0V/msec
Sequencing Delay Time	10msec min.
Tracking Accuracy	Power up: 200mV max.,
	Power down: 400mV max.
Capacitive Load Low ESR	8000µF max.
Power Good Signal Asserted Logic High	Vo=90%-110%Vo, nom
Start up time	7ms typ.

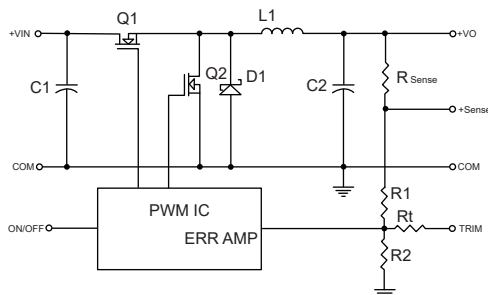

Figure 1.Simplified Schematic

GENERAL SPECIFICATIONS

Efficiency	See Table
Isolation Voltage	Non-isolation
Switching Frequency	300KHz typ.
Over Temperature Protection	130°C typ.
Operating Ambient Temperature Range	-40°C to +85°C
Power De-rating Curve	see Figure2, 3
Storage Temperature Range	-55°C to +125°C
MTBF MIL-STD-217F, GB, 25°C, Full Load	0.92Mhrs typ.
Dimensions:	SIP Package: 2.00 x 0.510 x 0.327 inches (50.8 x 12.95 x 8.30 mm)
	SMT Package: 1.30 x 0.530 x 0.346 inches (33.0 x 13.46 x 8.80 mm)
Structure	Non-potted With Open Frame Type
Weight	8.5 g

NOTE

1. Measured from high line to low line, Vo,set=3.3VDC.
2. Measured from full load to zero load, Vo,set=3.3VDC.
3. The output noise is measured with 10µf tantalum capacitor and 1µf ceramic capacitor across output.
4. The input terminal recommend to parallel with 100µF capacitor ESR< 100mΩ to reduce the input ripple voltage.
5. Suffix "N" to the model number with negative logic remote On/Off
 Model On.....open circuit or < 0.4VDC
 Module Off.....>+2.8VDC to Vin
6. Suffix "P" to the model number with power good function.

Vo,set(V)	Rtrim (K ⁻¹)
0.75	Open
1.2	22.33
1.5	13.0
1.8	9.0
2.0	7.4
2.5	5.0
3.3	3.12
5.0	1.47

Table 1.Suffix "A" to the model number External Resistor Values for programming output voltage

SIPSMT15-05 SERIES

15 AMP, POL CONVERTERS

Features

- ◆ Non-Isolated POL Converter
- ◆ SIP / SMT Converter
- ◆ Output Current 15AMP
- ◆ Input Voltage Range 3-5.5VDC
- ◆ Output Voltage Range 0.9-3.63VDC
- ◆ 300KHz Switching Frequency
- ◆ High Efficiency to 94%
- ◆ Over Temperature Protection
- ◆ Continuous Short Circuit Protection
- ◆ Remote On/Off Control
- ◆ UL/C-UL60950 Certified

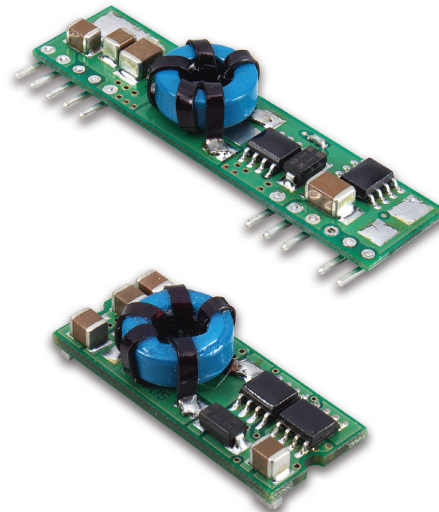

Mechanical Dimensions

Mechanical Specification

All Dimensions In Inches (mm)

Tolerances Inches: X.XX= ±0.02 , X.XXX= ±0.010
 Millimeters: X.X= ±0.5 , X.XX=±0.25

SIP Packages

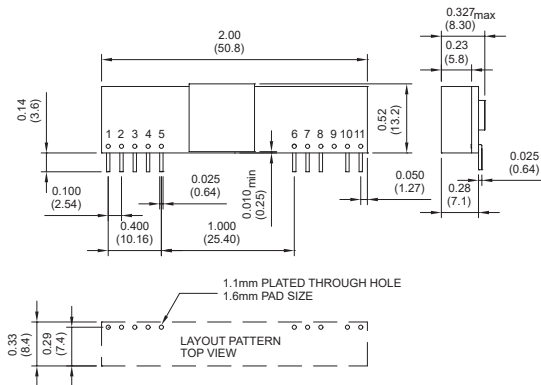

PIN CONNECTION	
PIN	Function
1	+Output
2	+Output
3	+Sense
4	+Output
5	Common
6	Common
7	+V Input
8	+V Input
9	No Pin
10	Trim
11	On/Off Control

SMT Packages

Bottom View of Board

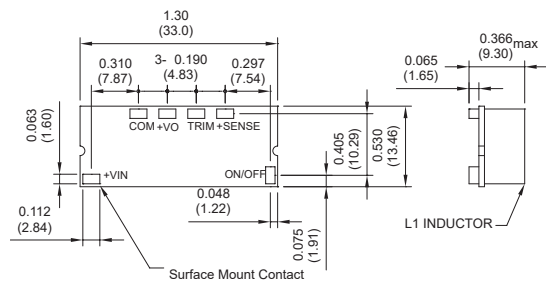

MODEL NUMBER	INPUT VOLTAGE	OUTPUT VOLTAGE	OUTPUT CURRENT	INPUT CURRENT		Efficiency (%)
				NO LOAD	FULL LOAD	
SIP15-05S33A	3.0-5.5 VDC	1.0 VDC	15 A	60 mA	3.658 A	82
	3.0-5.5 VDC	1.2 VDC	15 A	60 mA	4.286 A	84
	3.0-5.5 VDC	1.5 VDC	15 A	60 mA	5.172 A	87
	3.0-5.5 VDC	1.8 VDC	15 A	70 mA	6.136 A	88
	3.0-5.5 VDC	2.0 VDC	15 A	70 mA	6.742 A	89
	3.0-5.5 VDC	2.5 VDC	15 A	70 mA	8.152 A	92
SMT15-05S33A	4.5-5.5 VDC	3.3 VDC	15 A	70 mA	10.532 A	94

Derating Curve

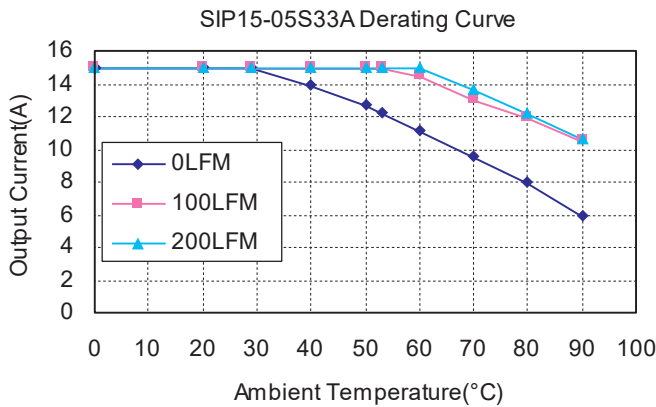

Figure2. Typical Power De-rating for 5Vin

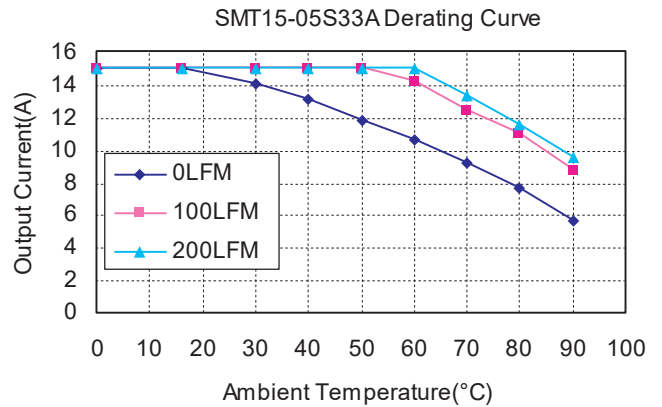

Figure3. Typical Power De-rating for 5Vin

Specifications

All Specifications Typical At Nominal Line, Full Load, and 25°C Unless Otherwise Noted

INPUT SPECIFICATIONS

Input Voltage Range	$V_o, set \leq V_{in} - 0.5VDC$
Under Voltage Lock-out	5V 3.0-5.5V Power up 2.8V typ. Power down 2.7V typ.
Input Filter Type	Capacitive
Positive Remote On/Off Control:	
Module On	Open Circuit or = Vin
Module Off	< 0.4Vdc

OUTPUT SPECIFICATIONS

Voltage Accuracy	±1.5% max.
Transient Response: 25% Step Load Change	< 200µs
Ripple and Noise, 20MHz BW (note 3)	20mVrms max. 50mVpk-pk max.
Temperature Coefficient	±0.03%/°C max.
Short Circuit Protection	Continuous
Line Regulation (note 1)	SIP15-05S33A ±0.2% max. SMT15-05S33A .. ±0.4% max.
Load Regulation (note 2)	±0.5% max.
Capacitive Load Low ESR	10000µF max.
External Trim Adj. Range (see Table1)	$V_o = 0.9 - 3.63Vdc$
Start up time	4.5ms typ.

GENERAL SPECIFICATIONS

Efficiency	See Table
Isolation Voltage	Non-isolation
Switching Frequency	300KHz typ.
Over Temperature Protection	120°C typ.
Operating Ambient Temperature Range	-40°C to +85°C
Power De-rating Curve	see Figure2, 3
Storage Temperature Range	-55°C to +125°C
MTBF MIL-STD-217F, GB, 25°C, Full Load	1.5Mhrs typ.
Dimensions:	SIP Package: 2.00 x 0.327 x 0.52 inches (50.8 x 8.3 x 13.2 mm) SMT Package: 1.30 x 0.53 x 0.366 inches (33.0 x 13.46 x 9.30 mm)
Structure	Non-potted With Open Frame Type
Weight	6.8 g

NOTE

- Measured from high line to low line, $V_o, set = 1.8VDC$.
- Measured from full load to zero load, $V_o, set = 3.3VDC$.
- The output noise is measured with 10µF tantalum capacitor and 1µF ceramic capacitor across output.
- The input terminal recommend to parallel with 100µF capacitor ESR < 20mΩ to reduce the input ripple voltage.
- Suffix "N" to the model number with negative logic remote On/Off
 Model On open circuit or < 0.4VDC
 Module Off > +2.8VDC to Vin

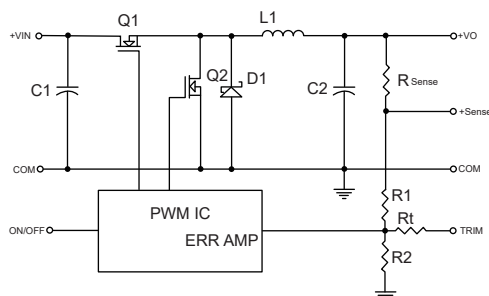

Figure 1. Simplified Schematic

$V_o, set (V)$	Rtrim (K ⁻¹)
0.75	Open
1.2	22.33
1.5	13.0
1.8	9.0
2.0	7.4
2.5	5.0
3.3	3.12
5.0	1.47

Table 1. External Resistor Values for programming output voltage

SIPSMT16-12 SERIES

16 AMP, POL CONVERTERS

Features

- ◆ Non-Isolated POL Converter
- ◆ SIP / SMT Converter
- ◆ Output Current 16AMP
- ◆ Input Voltage Range 9.0 –14VDC
- ◆ Output Voltage Range 0.75 – 5.0VDC
- ◆ 300KHz Switching Frequency
- ◆ High Efficiency to 94%
- ◆ Over Temperature Protection
- ◆ Continuous Short Circuit Protection
- ◆ Remote On/Off Control
- ◆ UL/C-UL60950 Certified

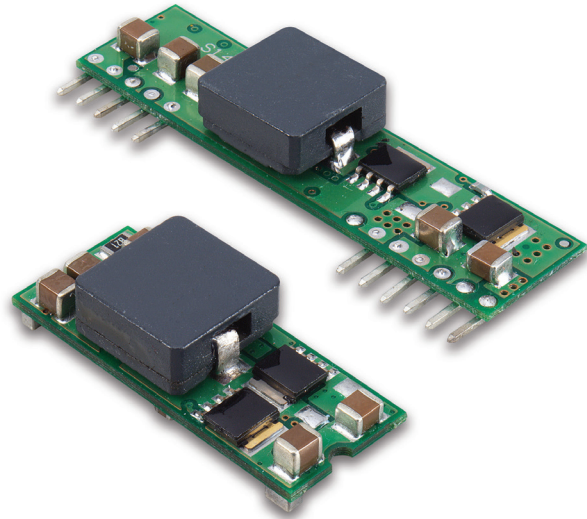

Mechanical Dimensions

Mechanical Specification

All Dimensions In Inches (mm)

Tolerances Inches: X.XX= ±0.02 , X.XXX= ±0.010
 Millimeters: X.X= ±0.5 , X.XX=±0.25

SIP Packages

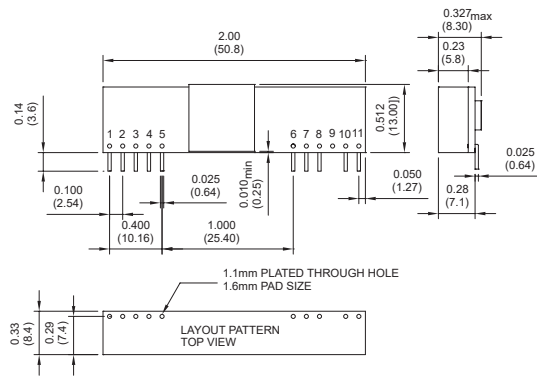

PIN CONNECTION	
PIN	Function
1	+Output
2	+Output
3	+Sense
4	+Output
5	Common
6	Common
7	+V Input
8	+V Input
9	No Pin
10	Trim
11	On/Off Control

SMT Packages

Bottom View of Board

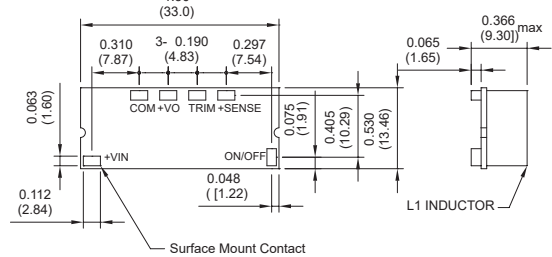

MODEL NUMBER	INPUT VOLTAGE	OUTPUT VOLTAGE	OUTPUT CURRENT	INPUT CURRENT		Efficiency (%)
				NO LOAD	FULL LOAD	
SIP16-12S05A	9.0-14 VDC	0.75 VDC	16 A	40 mA	1299 mA	77
	9.0-14 VDC	1.2 VDC	16 A	50 mA	1928 mA	83
	9.0-14 VDC	1.5 VDC	16 A	50 mA	2326 mA	86
SMT16-12S05A	9.0-14 VDC	1.8 VDC	16 A	60 mA	2727 mA	88
	9.0-14 VDC	2.0 VDC	16 A	60 mA	2996 mA	89
	9.0-14 VDC	2.5 VDC	16 A	65 mA	3704 mA	90
	9.0-14 VDC	3.3 VDC	16 A	75 mA	4783 mA	92
	9.0-14 VDC	5.0 VDC	16 A	75 mA	7092 mA	94

Derating Curve

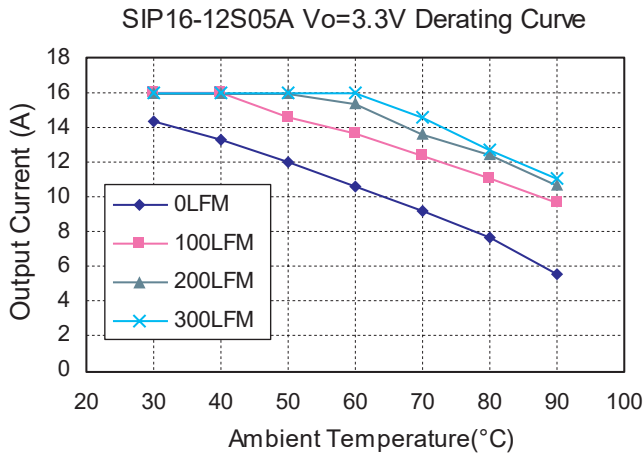

Figure2. Typical Power De-rating for 12Vin

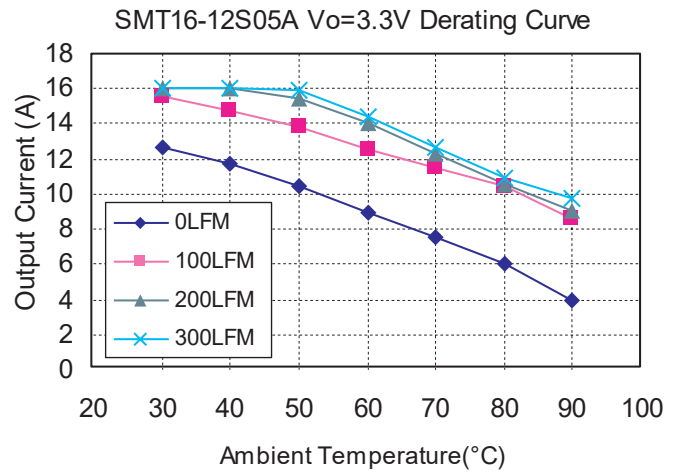

Figure3. Typical Power De-rating for 12Vin

Specifications

All Specifications Typical At Nominal Line, Full Load, and 25°C Unless Otherwise Noted

INPUT SPECIFICATIONS

Input Voltage Range	12V	9.0-14V
Under Voltage Lock-out	Power up	8.0V typ.
	Power down	7.7V typ.
Input Filter Type		Capacitive
Positive Remote On/Off Control:		
Module On		Open Circuit or =Vin
Module Off		< 0.4Vdc

OUTPUT SPECIFICATIONS

Voltage Accuracy	±1.5% max.
Transient Response: 25% Step Load Change	< 200µs
Ripple and Noise, 20MHz BW (note 3)	30mVrms max. 75mVpk-pk max.
Temperature Coefficient	±0.03%/°C max.
Short Circuit Protection	Continuous
Line Regulation (note 1)	±0.2% max.
Load Regulation (note 2)	±0.5% max.
Capacitive Load Low ESR	8000µF max.
External Trim Adj. Range (see Table1)	Vo=0.75-5.0Vdc
Start up time	7ms typ.

GENERAL SPECIFICATIONS

Efficiency	See Table
Isolation Voltage	Non-isolation
Switching Frequency	300KHz typ.
Over Temperature Protection	130°C typ.
Operating Ambient Temperature Range	-40°C to +85°C
Power Derating Curve	see Figure2, 3
Storage Temperature Range	-55°C to +125°C
MTBF	MIL-STD-217F, GB, 25°C, Full Load 0.98Mhrs typ.
Dimensions:	
SIP Package:	2.00 x 0.512 x 0.327 inches (50.8 x 13.00 x 8.30 mm)
SMT Package:	1.30 x 0.530 x 0.366 inches (33.0 x 13.46 x 9.30 mm)
Structure	Non-potted With Open Frame Type
Weight	10 g

NOTE

1. Measured from high line to low line, Vo,set=3.3VDC.
2. Measured from full load to zero load, Vo,set=3.3VDC.
3. The output noise is measured with 10µf tantalum capacitor and 1µf ceramic capacitor across output.
4. The input terminal recommend to parallel with 100µF capacitor ESR< 100mΩ to reduce the input ripple voltage.
5. Suffix "N" to the model number with negative logic remote On/Off
 Model On open circuit or < 0.4VDC
 Module Off..... >+2.8VDC to Vin

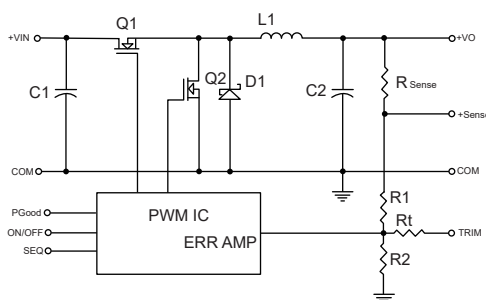

Figure 1.Simplified Schematic

Vo,set(V)	Rtrim (K ⁻¹)
0.7575	Open
1.2	22.46
1.5	13.05
1.8	9.024
2.0	7.417
2.5	5.009
3.3	3.122
5.0	1.472

Table 1.External Resistor Values for programming out voltage

SIPSMT16W-12 SERIES

16 AMP, POL CONVERTERS

Features

- ◆ Non-Isolated POL Converter
- ◆ SIP / SMT Package
- ◆ Output Current 16AMP
- ◆ Input Voltage Range 6.0-14VDC
- ◆ Output Voltage Range 0.7525-5.0VDC
- ◆ 300KHz Switching Frequency
- ◆ High Efficiency to 94%
- ◆ Over Temperature Protection
- ◆ Continuous Short Circuit Protection
- ◆ Remote On/Off Control
- ◆ Output Voltage Sequencing
- ◆ Power Good Signal
- ◆ UL/C-UL60950 Certified

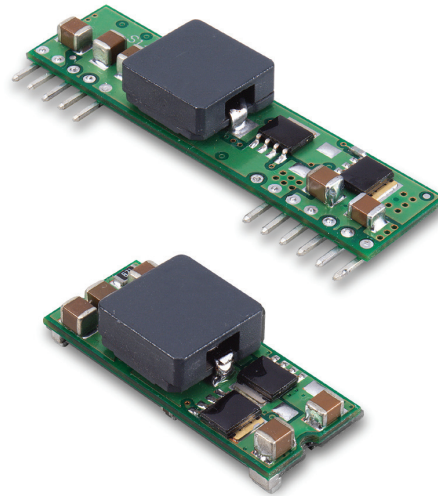

Mechanical Dimensions

Mechanical Specification

All Dimensions in Inches (mm)

Tolerance Inches: X.XX=±0.02, X.XXX=±0.010

Millimeters: X.X=±0.5, X.XX=±0.25

SIP Packages

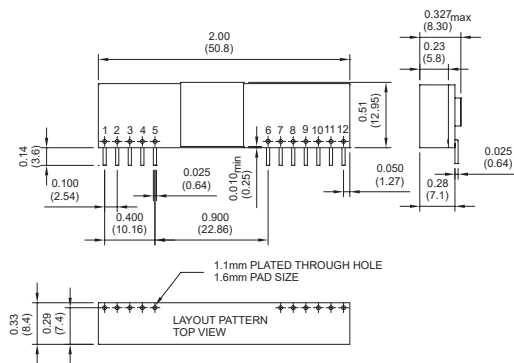

PIN CONNECTION	
PIN	Function
1	+Output
2	+Output
3	+Sense
4	+Output
5	Common
6	No Pin/PGOOD
7	Common
8	+V Input
9	+V Input
10	Sequency
11	Trim
12	On/Off Control

SMT Packages

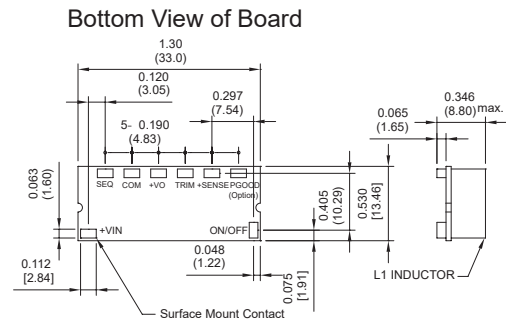

MODEL NUMBER	INPUT VOLTAGE	OUTPUT VOLTAGE	OUTPUT CURRENT	INPUT CURRENT		Efficiency (%)
				NO LOAD	FULL LOAD	
SIP16W-12S05A	6.0-14 VDC	0.7525 VDC	16 A	40 mA	1250 mA	80
	6.0-14 VDC	1.2 VDC	16 A	40 mA	1882 mA	85
	6.0-14 VDC	1.5 VDC	16 A	50 mA	2273 mA	88
SMT16W-12S05A	6.0-14 VDC	1.8 VDC	16 A	60 mA	2697 mA	89
	6.0-14 VDC	2.0 VDC	16 A	60 mA	2963 mA	90
	6.0-14 VDC	2.5 VDC	16 A	65 mA	3663 mA	91
	6.0-14 VDC	3.3 VDC	16 A	75 mA	4731 mA	93
	6.5-14 VDC	5.0 VDC	16 A	95 mA	7092 mA	94

Derating Curve

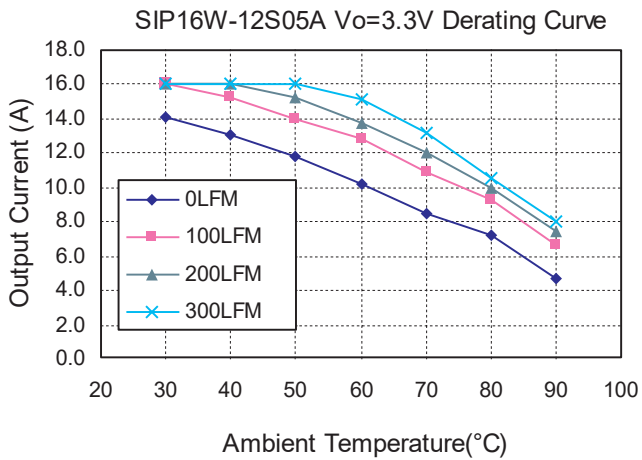

Figure2. Typical Power De-rating for 12Vin

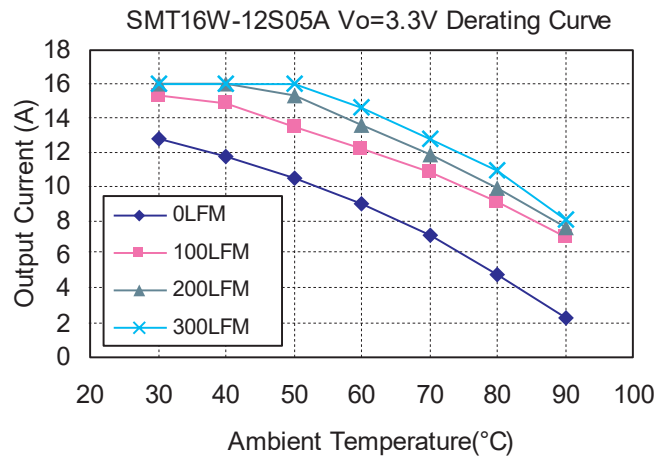

Figure3. Typical Power De-rating for 12Vin

Specifications

All Specifications Typical At Nominal Line, Full Load, and 25°C Unless Otherwise Noted

INPUT SPECIFICATIONS

Input Voltage Range	12V	6.0-14.0V
	12V	6.5-14.0V
Under Voltage Lock-out	Power up	5.0V typ.
	Power down	4.0V typ.
Input Filter Type		Capacitive
Positive Remote On/Off Control :		
Module On	Open Circuit or = Vin	
Module Off	< 0.4 Vdc	

OUTPUT SPECIFICATIONS

Voltage Accuracy	±1.5% max.
Transient Response: 25% Step Load Change	< 200µs
Ripple and Noise, 20MHz BW (note 3)	30mV rms max. 75mV pk-pk max.
Temperature Coefficient	±0.03%/°C max.
Short Circuit Protection	Continuous
Line Regulation (note 1)	±0.2% max.
Load Regulation (note 2)	±0.5% max.
External Trim Adj. Range (see Table1)	Vo=0.75-5.0Vdc
Sequencing Slew Rate Capability (dVseq/dt)	0.1-1.0V/msec
Sequencing Delay Time	10msec min.
Tracking Accuracy	Power up: 200mV max., Power down: 400mV max.
Capacitive Load Low ESR	8000µF max.
Power Good Signal Asserted Logic High	Vo=90%-110%Vo, nom.
Start up time	7ms typ.

GENERAL SPECIFICATIONS

Efficiency	See Table
Isolation Voltage	Non-isolation
Switching Frequency	300KHz typ.
Over Temperature Protection	130°C typ.
Operating Ambient Temperature Range	-40°C to +85°C
Power Derating Curve	see Figure2, 3
Storage Temperature Range	-55°C to +125°C
MTBF	MIL-STD-217F, GB, 25°C, Full Load 0.92Mhrs typ.
Dimensions:	
SIP Package:	2 x 0.51 x 0.327 inches (50.8 x 12.95 x 8.3 mm)
SMT Package:	1.3 x 0.53 x 0.346 inches (33.0 x 13.46 x 8.8 mm)
Structure	Non-potted With Open Frame Type
Weight	8.5 g

NOTE

- Measured from high line to low line, Vo,set=3.3VDC.
- Measured from full load to zero load, Vo,set=3.3VDC.
- The output noise is measured with 10µf tantalum capacitor and 1µf ceramic capacitor across output.
- The input terminal recommend to parallel with 100µF capacitor ESR< 100mΩ to reduce the input ripple voltage.
- Suffix "N" to the model number with negative logic remote On/Off
 Model On Open Circuit or < 0.4VDC
 Module Off >+2.8VDC to Vin
- Suffix "P" to the model number with power good function.

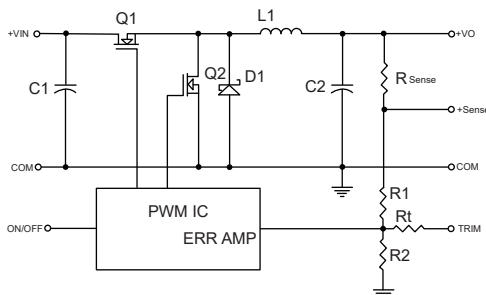

Figure 1. Simplified Schematic

Vo,set(V)	Rtrim (K ⁻¹)
0.75	Open
1.2	22.33
1.5	13.0
1.8	9.0
2.0	7.4
2.5	5.0
3.3	3.12
5.0	1.47

Table 1. External Resistor Values for programming out voltage

SIP20W-12 SERIES

20 AMP, POL CONVERTERS

Features

- ◆ Non-Isolated POL Converter
- ◆ SIP Package
- ◆ Output Current 20AMP
- ◆ Input Voltage Range 6-14VDC
- ◆ Output Voltage Range 0.7525-5VDC
- ◆ 300KHz Switching Frequency
- ◆ High Efficiency to 94%
- ◆ Over Temperature Protection
- ◆ Continuous Short Circuit Protection
- ◆ Remote On/Off Control
- ◆ Output Voltage Sequencing
- ◆ Power Good Signal
- ◆ UL/C-UL60950 Certified

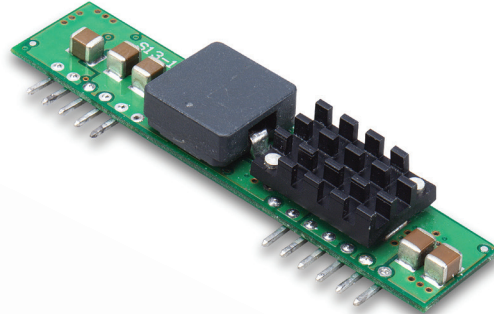

Mechanical Dimensions

Mechanical Specification
 All Dimensions in Inches (mm)
 Tolerance Inches: X.XX=±0.02, X.XXX=±0.010
 Millimeters: X.X=±0.5, X.XX=±0.25

SIP Packages

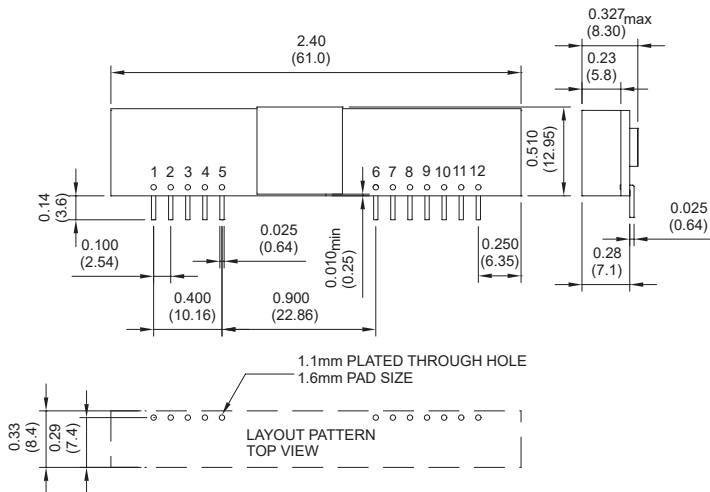

PIN CONNECTION	
PIN	Function
1	+Output
2	+Output
3	+Sense
4	+Output
5	Common
6	No Pin/PGOOD
7	Common
8	+V Input
9	+V Input
10	Sequency
11	Trim
12	On/Off Control

MODEL NUMBER	INPUT VOLTAGE	OUTPUT VOLTAGE	OUTPUT CURRENT	INPUT CURRENT		Efficiency (%)
				NO LOAD	FULL LOAD	
SIP20W-12S05A	6.0-14 VDC	0.7525 VDC	20 A	40 mA	1603 mA	78
	6.0-14 VDC	1.2 VDC	20 A	50 mA	2381 mA	84
	6.0-14 VDC	1.5 VDC	20 A	50 mA	2874 mA	87
	6.0-14 VDC	1.8 VDC	20 A	50 mA	3409 mA	88
	6.0-14 VDC	2.0 VDC	20 A	60 mA	3745 mA	89
	6.0-14 VDC	2.5 VDC	20 A	65 mA	4630 mA	90
	6.0-14 VDC	3.3 VDC	20 A	75 mA	5978 mA	92
	6.5-14 VDC	5.0 VDC	20 A	95 mA	8865 mA	94

Derating Curve

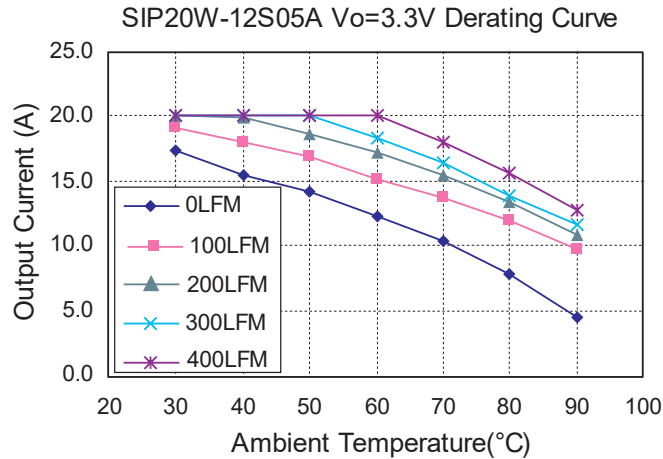

Figure2. Typical Power De-rating for 12Vin

Specifications

All Specifications Typical At Nominal Line, Full Load, and 25°C Unless Otherwise Noted

INPUT SPECIFICATIONS

Input Voltage Range	12V 6.0-14.0V
	12V 6.5-14.0V
Under Voltage Lock-out	Power up 5.0V typ.
	Power down 4.0V typ.
Input Filter Type	Capacitive
Positive Remote On/Off Control :	
Module On	Open Circuit or = Vin
Module Off	< 0.4 Vdc

OUTPUT SPECIFICATIONS

Voltage Accuracy	±1.5% max.
Transient Response: 25% Step Load Change	< 200µs
Ripple and Noise, 20MHz BW (note 3)	30mV rms max.
	75mV pk-pk max.
Temperature Coefficient	±0.03%/C max.
Short Circuit Protection	Continuous
Line Regulation (note 1) SIP Package	±0.2% max.
Load Regulation (note 2)	±0.5% max.
External Trim Adj. Range (see Table1)	Vo=0.75-5.0Vdc
Sequencing Slew Rate Capability (dVseq/dt)	0.1-1.0V/msec
Sequencing Delay Time	10msec min.
Tracking Accuracy	Power up: 200mV max.,
	Power down: 400mV max.
Capacitive Load Low ESR	8000µF max.
Power Good Signal Asserted Logic High	Vo=90%-110%Vo, nom.
Start up time	7ms typ.

GENERAL SPECIFICATIONS

Efficiency	See Table
Isolation Voltage	Non-isolation
Switching Frequency	300KHz typ.
Over Temperature Protection	130°C typ.
Operating Ambient Temperature Range	-40°C to +85°C
Power Derating Curve	see Figure2, 3
Storage Temperature Range	-55°C to +125°C
MTBF MIL-STD-217F, GB, 25°C, Full Load	0.9Mhrs typ.
Dimensions:	
SIP Package:	2.40 x 0.510 x 0.327 inches
	(61.0 x 12.95 x 8.30 mm)
Structure	Non-potted With Open Frame Type
Weight	11 g

NOTE

1. Measured from high line to low line, Vo,set=3.3VDC.
2. Measured from full load to zero load, Vo,set=3.3VDC.
3. The output noise is measured with 10µf tantalum capacitor and 1µf ceramic capacitor across output.
4. The input terminal recommend to parallel with 200µF capacitor ESR< 25mΩ to reduce the input ripple voltage.
5. Suffix "N" to the model number with negative logic remote On/Off
 Model On Open Circuit or < 0.4VDC
 Module Off >+2.8VDC to Vin
6. Suffix "P" to the model number with power good function.

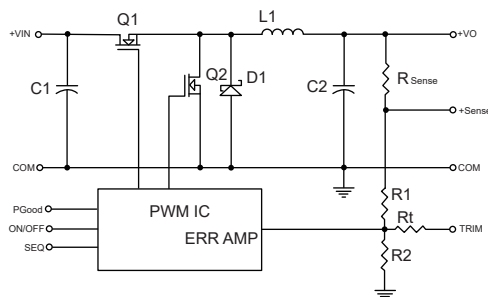

Figure 1.Simplified Schematic

Vo,set(V)	Rtrim (K ⁻¹)
0.7575	Open
1.2	22.46
1.5	13.05
1.8	9.024
2.0	7.417
2.5	5.009
3.3	3.122
5.0	1.472

Table 1.External Resistor Values for programming out voltage

Rapid Standard-Modification, Value Added & Customized Power Supplies. Cincon offers a high degree of flexibility in product designs.

Cincon provides a broad range of standard products that address the needs of many applications, there are occasions when a standard product doesn't address all your application requirements.

By years of experience in developing our customers with solutions on demand, do not hesitate to talk to Cincon to obtain your preferred products.

Cincon Headquarters

14F, No. 306, Section 4, Hsin Yi Rd., Taipei, Taiwan
Tel: (886-2) 2708-6210
E-mail: sales@cincon.com.tw

Cincon USA

1655 Mesa Verde Ave, Ste 180
Ventura, CA 93003 USA
Tel: (805) 639-3350
E-mail: info@cincon.com

POWER SUPPLY - REQUEST FOR QUOTE - by fax +886 2 2702 9852

Company _____ Date _____

First Name _____ Last Name _____

Country _____ City _____

Address _____

Telephone _____ Fax _____

E-mail _____

Product Type

Application

Output Voltages

Output Currents

Input Voltages

Efficiency

Isolation

Protection

Storage / Operating Temperature Range

Safety Standard

EMC Standard

Mechanical Description

Remarks

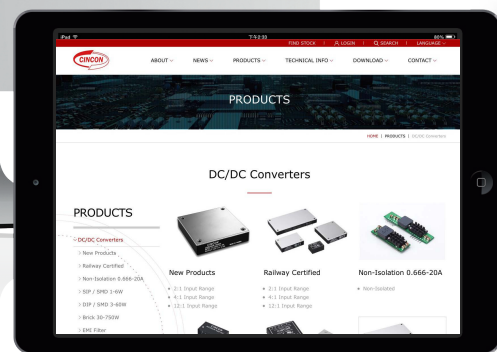
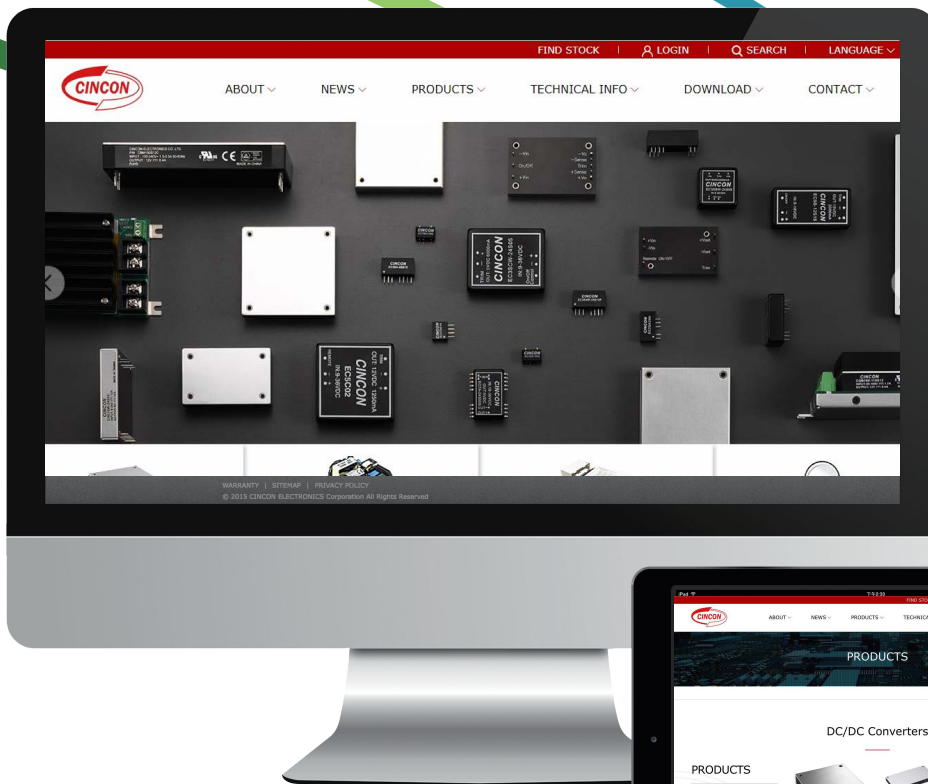

Visit Our Website
WWW.CINCON.COM

On Cincon Website

- ✓ You can download latest datasheets & application notes
- ✓ You can find all new product releases and latest news
- ✓ You can find Cincon sales representative & distributors
- ✓ You can check stock and send product inquiry to us

Let Cincon Power Your Idea



Getronic Vertrieb elektronischer Bauelemente GmbH
Stawedder 29
25462 Rellingen
Germany

Tel: 04101/8040-100
E-Mail: service@getronic.de
www.getronic.de



WWW.CINCON.COM

CINCON HEADQUARTERS

14F , No. 306, Section 4, Hsin Yi Road Taipei, Taiwan, R.O.C.
Tel : (886-2) 2708-6210 | Fax : (886-2) 2702-9852
E-mail : sales@cincon.com.tw

CINCON USA

1655 Mesa Verde Ave, Ste 180 Ventura , CA 93003 USA
Tel : (805) 639-3350 | Fax : (805) 639-4101
E-mail : info@cincon.com