



LFM200S SERIES 200 WATT AC-DC POWER SUPPLY WITH PFC

Features

- Universal Input Range 85~264Vac
- High Efficiency up to 94%
- Class I
- 25.4mm Low Profile Package
- No Load Input Power Consumption<0.3W
- 48V, 54V No Load Input Power Consumption<0.4W
- Approval IEC/EN/UL 62368-1 Ed 3.0
- Approval EN55032 and CISPR/FCC Class B
- Meets IEC/EN 60335-1
- Operating Altitude 5000m
- Continuous Short Circuit Protection
- Over Voltage Protection
- Over Temperature Protection
- High Power Density 28.35W/Inches³
- Active PFC Function
- Over Voltage Category OVC II & OVC III



MODEL NUMBER	OUTPUT VOLTAGE	OUTPUT CURRENT			RIPPLE & NOISE NOTE1	VOLTAGE ACCURACY NOTE2	LINE REGULATION NOTE3	LOAD REGULATION NOTE4	%EFF. (Typ) NOTE5
		With Fan NOTE6	Without Conduction Cooling	With Conduction Cooling NOTE7					
LFM200S120C	12 V	16.67 A	9.17 A	14.17 A	150 mV	±1%	±0.2%	±0.5%	92%
LFM200S150C	15 V	13.33 A	7.33 A	11.33 A	150 mV	±1%	±0.2%	±0.5%	92%
LFM200S240C	24 V	8.33 A	4.58 A	7.08 A	200 mV	±1%	±0.2%	±0.5%	94%
LFM200S280C	28 V	7.14 A	3.93 A	6.07 A	200 mV	±1%	±0.2%	±0.5%	93%
LFM200S300C	30 V	6.66 A	3.67 A	5.67 A	200 mV	±1%	±0.2%	±0.5%	93%
LFM200S360C	36 V	5.55 A	3.06 A	4.72 A	200 mV	±1%	±0.2%	±0.5%	94%
LFM200S480C	48 V	4.16 A	2.29 A	3.54 A	200 mV	±1%	±0.2%	±0.5%	94%
LFM200S540C	54 V	3.7 A	2.04 A	3.15 A	200 mV	±1%	±0.2%	±0.5%	93%

Note:

1. Add a 0.1uF ceramic capacitor and a 10uF E.L. capacitor to output for ripple & noise measuring @20MHz BW.
2. Voltage accuracy is set at full load.
3. Line regulation is measured from 100Vac to 240Vac with full load.
4. Load regulation is measured from 10% to 100% full load.
5. Typical efficiency at 230 Vac and full load at 25°C.
6. Forced air convection with 14CFM above 110Vac.
7. With addition cooling conduction plate, 17.78 by 17.78 cm with min. 0.2 cm thick, as below.



LFM200S Series

PART NUMBER

Series	Number of Outputs	Nominal Output Voltage	Type	Mounting Inserts
LFM200	O	XXX	X	-YZ
LFM200	S : Single	120 : 12V 150 : 15V 240 : 24V 280 : 28V 300 : 30V 360 : 36V 480 : 48V 540 : 54V	C : With Cover	Blank : Through Hole C0 : Threaded Hole

Part Number Example:

LFM200S120C-C0: With Cover 200W, Single 12Vdc Output, Threaded Hole



LFM200S Series

TECHNICAL SPECIFICATIONS

(All specifications are typical at nominal input, full load at 25°C unless otherwise noted.)

ABSOLUTE MAXIMUM RATINGS

PARAMETER	NOTES and CONDITIONS	Device	Min.	Typ.	Max.	Units
Input Voltage	Safety approvals only to the AC input	All	85		264	V _{ac}
Input Voltage		All	115		370	V _{dc}
Operating Temperature	See Derating Curve	All	-40		80	°C
Operating Case Temperature	At the center of base plate (T _c = Case temperature)	All	-40		90	°C
Storage Temperature		All	-40		85	°C
Operating Altitude	IEC/EN/UL 62368-1 OVC II IEC/EN/UL 62368-1 OVC III	All			5000 2000	m

INPUT CHARACTERISTICS

PARAMETER	NOTES and CONDITIONS	Device	Min.	Typ.	Max.	Units
Operating Voltage Range		All	100		240	V _{ac}
Input Frequency Range		All	47		63	Hz
Maximum Input Current	100% Load, V _{in} =100V _{ac}	All			3.15	A
Leakage Current	Contact leakage current Earth leakage current	All			100 300	uA
Inrush Current	V _{in} =240V _{ac} , Cold Start @25°C	All			85	A
Power Factor	230V _{ac} @ Full load	All	0.96	0.98		

OUTPUT CHARACTERISTICS

PARAMETER	NOTES and CONDITIONS	Device	Min.	Typ.	Max.	Units
Output Voltage Set Point	V _{in} =Nominal V _{in} , I _o =I _o max., T _c =25°C	LFM200S120C	11.88	12	12.12	V _{dc}
		LFM200S150C	14.85	15	15.15	
		LFM200S240C	23.76	24	24.24	
		LFM200S280C	27.72	28	28.28	
		LFM200S300C	29.7	30	30.3	
		LFM200S360C	35.64	36	36.36	
		LFM200S480C	47.52	48	48.48	
Operating Output Current Range	V _{in} =85V _{ac} ~264V _{ac} , See Derating Curve	LFM200S120C	0		16.67	A
		LFM200S150C	0		13.33	
		LFM200S240C	0		8.33	
		LFM200S280C	0		7.14	
		LFM200S300C	0		6.66	
		LFM200S360C	0		5.55	
		LFM200S480C	0		4.16	
LFM200S540C	0		3.7			
Holdup Time	V _{in} =115V _{ac}	All	10	12		ms
Output Voltage Regulation						
Load Regulation	10% Load to full load	All			±0.5	%
Line Regulation	V _{in} =High line to low line	All			±0.2	%
Output Voltage Adjustment	P _o ≤ max. rated power, I _o ≤ I _o max.	All	-5		+5	%



LFM200S Series

PARAMETER	NOTES and CONDITIONS	Device	Min.	Typ.	Max.	Units
Over Voltage Protection	Latch off (AC recycle to reset)	LFM200S120C			16	V _{dc}
		LFM200S150C			20	
		LFM200S240C			32	
		LFM200S280C			35	
		LFM200S300C			35	
		LFM200S360C			45	
		LFM200S480C			55	
		LFM200S540C			63	
Over Current Protection	Auto recovery (output is rated load)	All	125	145	165	%
Short Circuit Protection	Auto recovery	All				
Over Temperature Protection	Auto recovery	All				
Output Ripple and Noise	1. Add a 0.1uF ceramic capacitor and a 10uF aluminum electrolytic capacitor to output 2. Oscilloscope is 20MHz band width. 3. Ambient Temperature=25°C	LFM200S120C			150	mV
		LFM200S150C			150	
		LFM200S240C			200	
		LFM200S280C			200	
		LFM200S300C			200	
		LFM200S360C			200	
		LFM200S480C			200	
		LFM200S540C			200	
Load Capacitance	1. V _{in} =115V _{ac} and 230V _{ac} 2. Output is max. load 3. Ambient temperature=25°C	LFM200S120C			6800	uF
		LFM200S150C			5360	
		LFM200S240C			3440	
		LFM200S280C			3440	
		LFM200S300C			3220	
		LFM200S360C			2680	
		LFM200S480C			2000	
		LFM200S540C			1560	
Efficiency	1. Input Voltage is 230Vac 2. Output is rated load 3. Ambient temperature=25°C	LFM200S120C		92		%
		LFM200S150C		92		
		LFM200S240C		94		
		LFM200S280C		93		
		LFM200S300C		93		
		LFM200S360C		94		
		LFM200S480C		94		
		LFM200S540C		93		

ISOLATION CHARACTERISTICS

PARAMETER	NOTES and CONDITIONS	Device	Min.	Typ.	Max.	Units
Input to Output	1 Minute (without dielectric breakdown)	All			4250	V _{ac}
Input to Earth (Ground)	1 Minute (without dielectric breakdown)	All			2000	V _{ac}
Output to Earth (Ground)	1 Minute (without dielectric breakdown)	All			2000	V _{ac}
Isolation Resistance	Input to output	All	100			MΩ

FEATURE CHARACTERISTICS

PARAMETER	NOTES and CONDITIONS	Device	Min.	Typ.	Max.	Units
Switching Frequency		15V		130		kHz
		Others		110		



LFM200S Series

GENERAL SPECIFICATIONS

PARAMETER	NOTES and CONDITIONS	Device	Min.	Typ.	Max.	Units
MTBF	I _o =100%; T _a =25°C per MIL-HDBK-217F	All	450			k hours
Life Time	@75% Load, 40°C	All	26			k hours
Humidity	Non-condensing	All			93	% RH
Shock	Meet MIL-STD-810F Table 516.5, Table 516.5-1 10ms, each axis 3 times(±X、±Y、±Z axis)	All		75		g
Vibration	Meet MIL-STD-810F Table 514.5C-VIII, 15~2000Hz, X、Y、Z axis, 1 hour (each axis),. Total 3 hrs.	All		4		g
Weight		All		220		grams
Dimensions			3.09x2.28x1.00 Inches (78.6x57.9x25.4 mm)			
Safety	Class I, IEC/EN/UL 62368-1					Ed. 3.0
EMC Emission	EN 55032:2015+A11:2020, EN 61000-6-4:2019, EN 61204-3:2018, EN 61000-3-2:2019+A1:2021, EN 61000-3-3:2013+A2:2021, 47 CFR FCC Part 15					
Conducted Disturbance	EN 55032, 47 CFR FCC Part 15					Class B
Radiated Disturbance	EN 55032, 47 CFR FCC Part 15					Class B
Harmonic Current Emissions	EN 61000-3-2:2019+A1:2021					Class A, C, D
Voltage Fluctuations & Flicker	EN 61000-3-3:2013+A2:2021					Criterion A
EMC Immunity	EN 55035:2017+A11:2020, EN 61000-6-2:2019, EN 61204-3:2018					
Electrostatic Discharge (ESD)	IEC 61000-4-2:2008 Air Discharge: ±8kV, Contact Discharge: ±4kV					Criterion A
Radio-Frequency, Continuous Radiated Disturbance	IEC 61000-4-3:2020					Criterion A
Electrical Fast Transient (EFT)	IEC 61000-4-4:2012, ±2kV					Criterion A
Surge	IEC 61000-4-5:2014+A1:2017, L-N: ±2kV, L-E (Ground): ±4kV					Criterion A
Conducted Disturbances, Induced by RF Fields	IEC 61000-4-6:2013+COR1:2015					Criterion A
Power Frequency Magnetic Field	IEC 61000-4-8:2009					Criterion A
Voltage Dips	IEC 61000-4-11:2020, Dip: 30% 10ms, Dip: 60% 100ms, Dip >95% 5000ms					Criterion A
Voltage Interruptions	IEC 61000-4-11:2020, >95% 5000ms					Criterion B
Application Note Link						LFM200S Series App Notes



CHARACTERISTIC CURVE

Power Derating Curve

Output Power vs Ambient Temperature

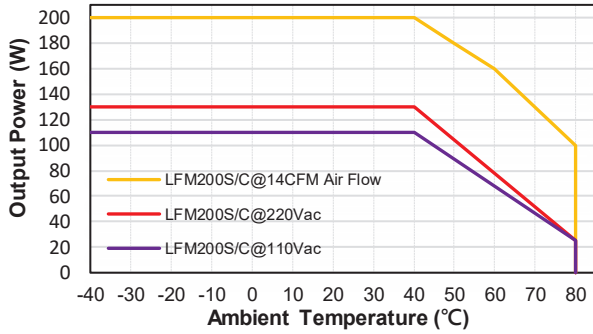

Output Power & Input Voltage

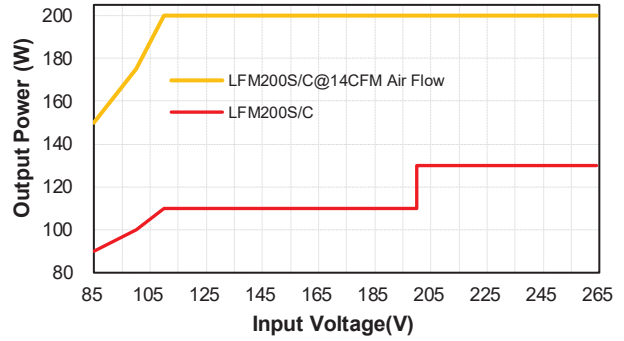

Conduction Convection with External Baseplate (17.78cmx17.78cmx0.2cm)

Output Power vs Ambient Temperature

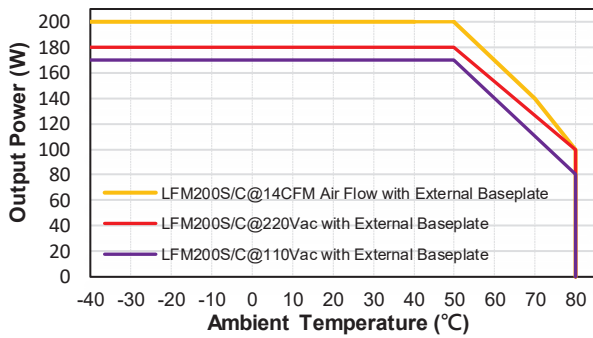

Output Power & Input Voltage

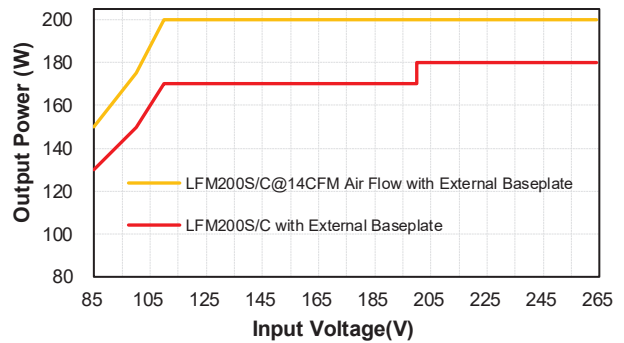

Output Power vs Case Temperature (Tc)

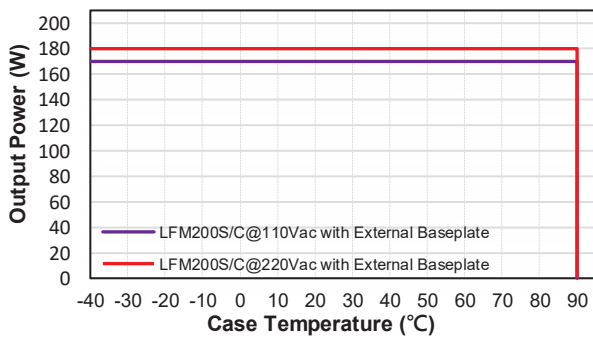



LFM200S Series

Performance Data

LFM200S120 (Eff Vs Io)

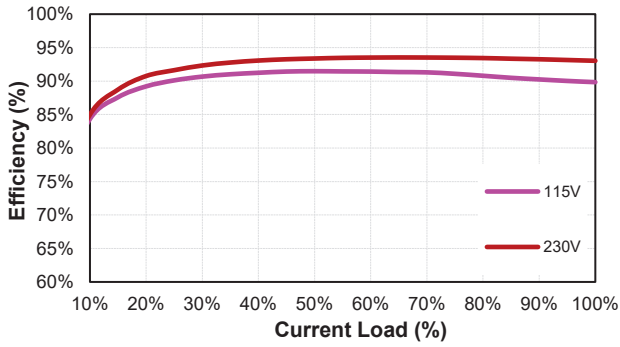

LFM200S150 (Eff Vs Io)

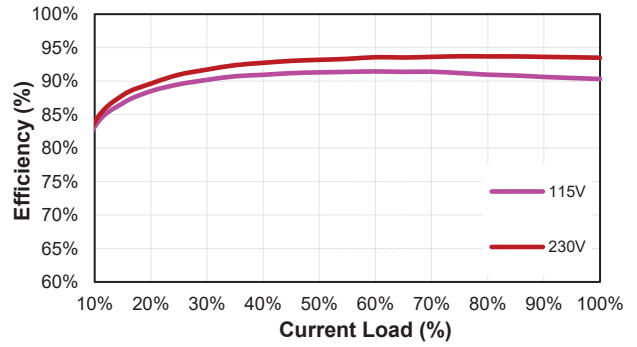

LFM200S240 (Eff Vs Io)

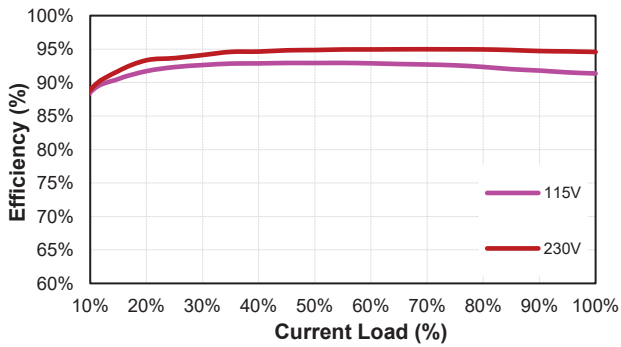

LFM200S280 (Eff Vs Io)

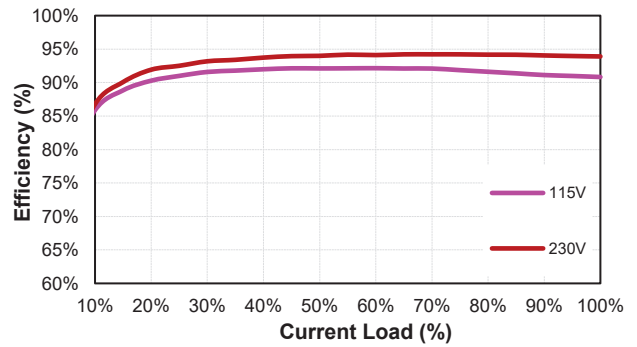

LFM200S300 (Eff Vs Io)

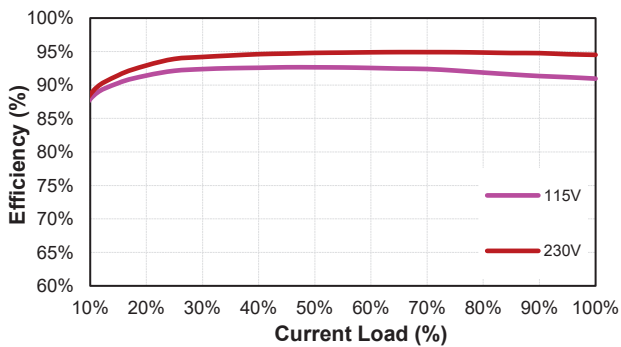

LFM200S360 (Eff Vs Io)

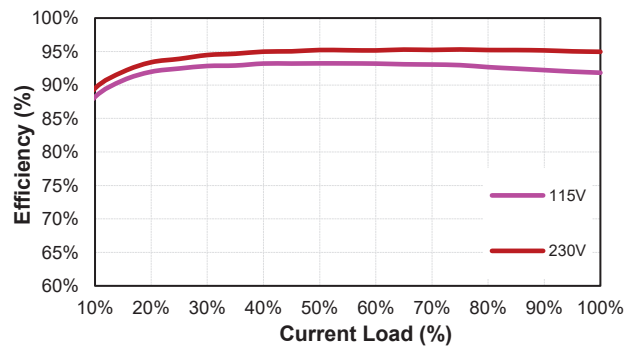

LFM200S480 (Eff Vs Io)

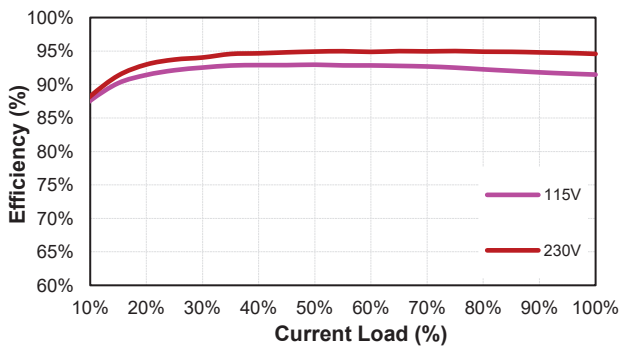

LFM200S540 (Eff Vs Io)

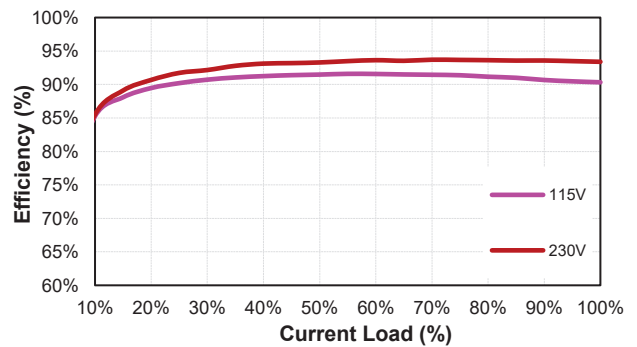



LFM200S Series

MECHANICAL SPECIFICATION

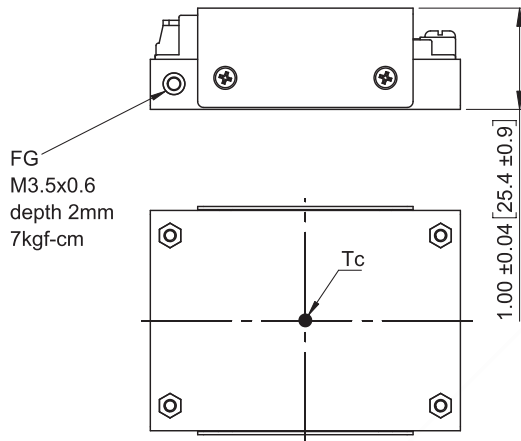
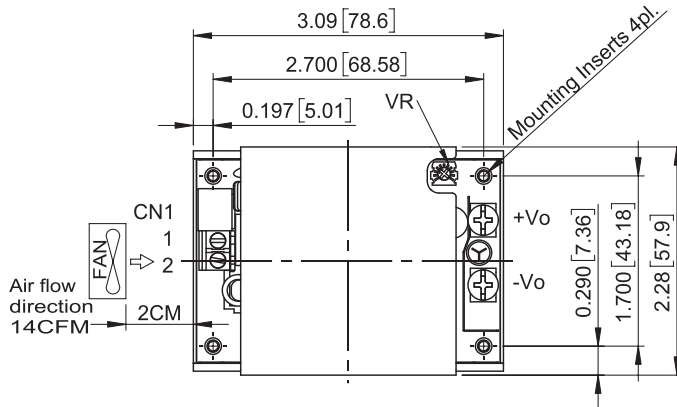

LFM200SXXXXC LFM200SXXXXC-C0

All Dimensions in Inches[mm]

Tolerance Inches: x.xx=±0.03, x.xxx=±0.020

Millimeters: x.x=±0.7, x.xx=±0.50

AC Input Connector(CN1):ECE ETB22

Pin	Function	Mating Wire Range
1	ACL	14~18 AWG
2	ACN	

DC Output Connector:KANG YANG PCB-58M4

Function	The screws locked torque
+Vo	M4 7kgf-cm
-Vo	

Mounting Inserts

Series	Option
Blank	∅ 3.2 Through depth 10.5mm
-C0	M3x0.5 Threaded depth 10.5mm

CINCON Electronics Co. Ltd.
 Add: 14F, No. 306, Sec.4, Hsin Yi Rd., Taipei, Taiwan
 Tel: 886-2-27086210
 Fax: 886-2-27029852
 E-mail: sales@cincon.com
 Web: www.cincon.com



LFM300S SERIES 300 WATT AC-DC POWER SUPPLY WITH PFC

Features

- Universal Input Range 85~264Vac
- High Efficiency up to 94%
- Class I
- 25.4mm Low Profile Package
- No Load Input Power Consumption<0.3W
- Approval IEC/EN/UL 62368-1 Ed 3.0
- Approval EN 55032 and CISPR/FCC Class B
- Meets IEC/EN 60335-1
- Operating Altitude 5000m
- Continuous Short Circuit Protection
- Over Voltage Protection
- Over Temperature Protection
- High Power Density 32.1W/Inches³
- Active PFC Function
- Over Voltage Category OVC II & OVC III



MODEL NUMBER	OUTPUT VOLTAGE	OUTPUT CURRENT			RIPPLE & NOISE NOTE1	VOLTAGE ACCURACY NOTE2	VOLTAGE ADJ. RANGE	LINE REGULATION NOTE3	LOAD REGULATION NOTE4	%EFF. (Typ.) NOTE5
		With Fan NOTE6	Without Conduction Cooling	With Conduction Cooling NOTE7						
LFM300S120C	12 V	25 A	13.34 A	20.83 A	150 mV	±1%	11.4-12.6 V	±0.3%	±0.5%	93%
LFM300S150C	15 V	20 A	10.67 A	16.6 A	150 mV	±1%	14.25-15.75 V	±0.3%	±0.5%	93%
LFM300S240C	24 V	12.5 A	6.67 A	10.4 A	240 mV	±1%	22.8-25.2 V	±0.3%	±0.5%	94%
LFM300S280C	28 V	10.7 A	5.71 A	8.90 A	280 mV	±1%	26.6-29.4 V	±0.3%	±0.5%	94%
LFM300S300C	30 V	10 A	5.33 A	8.33 A	300 mV	±1%	28.5-31.5 V	±0.3%	±0.5%	94%
LFM300S480C	48 V	6.25 A	3.33 A	5.20 A	480 mV	±1%	45.6-50.4 V	±0.3%	±0.5%	94%
LFM300S540C	54 V	5.56 A	2.96 A	4.63 A	540 mV	±1%	51.3-56.7 V	±0.3%	±0.5%	93%

Note:

1. Add a 0.1uF ceramic capacitor and a 10uF E.L. capacitor to output for ripple & noise measuring @20MHz BW.
2. Voltage accuracy is set at full load.
3. Line regulation is measured from 100Vac to 240Vac with full load.
4. Load regulation is measured from 10% to 100% full load.
5. Typical efficiency at 230 Vac and full load at 25°C.
6. Forced air convection with 14CFM above 115Vac.
7. With addition cooling conduction plate, 22.8 by 22.8 cm with min. 0.2 cm thick, as below.

PART NUMBER

Series	Number of Outputs	Nominal Output Voltage	Type	Mounting Inserts
LFM300	O	XXX	X	-YZ
LFM300	S : Single	120 : 12V 150 : 15V 240 : 24V 280 : 28V 300 : 30V 480 : 48V 540 : 54V	C : With Cover	Blank : Through Hole C0 : Threaded Hole

Part Number Example:

LFM300S120C-C0: With Cover 300W, Single 12Vdc Output, Threaded Hole

www.cincon.com



LFM300S Series

TECHNICAL SPECIFICATIONS

(All specifications are typical at nominal input, full load at 25°C unless otherwise noted.)

ABSOLUTE MAXIMUM RATINGS

PARAMETER	NOTES and CONDITIONS	Device	Min.	Typ.	Max.	Units
Input Voltage		All	85		264	V _{ac}
Operating Temperature	See Derating Curve	All	-40		80	°C
Operating Case Temperature	At the center of base plate (T _c = Case temperature)	All	-40		90	°C
Storage Temperature		All	-40		85	°C
Operating Altitude	IEC/EN/UL 62368-1 OVC II IEC/EN/UL 62368-1 OVC III	All			5000 2000	m

INPUT CHARACTERISTICS

PARAMETER	NOTES and CONDITIONS	Device	Min.	Typ.	Max.	Units
Operating Voltage Range		All	100		240	V _{ac}
Input Frequency Range		All	47		63	Hz
Maximum Input Current	100% Load, V _{in} =100V _{ac}	All			5.0	A
Leakage Current	Contact leakage current Earth leakage current	All			100 300	uA
Inrush Current	V _{in} =240V _{ac} , Cold Start @25°C	All			105	A
Power Factor	230V _{ac} @ Full load	All		0.92		

OUTPUT CHARACTERISTICS

PARAMETER	NOTES and CONDITIONS	Device	Min.	Typ.	Max.	Units
Output Voltage Set Point	V _{in} =Nominal V _{in} , I _o =I _o max., T _c =25°C	LFM300S120	11.88	12	12.12	V _{dc}
		LFM300S150	14.85	15	15.15	
		LFM300S240	23.76	24	24.24	
		LFM300S280	27.72	28	28.28	
		LFM300S300	29.7	30	30.3	
		LFM300S480	47.52	48	48.48	
Operating Output Current Range	V _{in} =85V _{ac} ~264V _{ac} , See Derating Curve	LFM300S120	0		25.0	A
		LFM300S150	0		20.0	
		LFM300S240	0		12.5	
		LFM300S280	0		10.7	
		LFM300S300	0		10.0	
		LFM300S480	0		6.25	
LFM300S540	0		5.56			
Holdup Time	V _{in} =115V _{ac}	All		12		ms
Output Voltage Regulation						
Load Regulation	10% Load to full load	All			±0.5	%
Line Regulation	V _{in} =High line to low line	All			±0.3	%
Output Voltage Adjustment	P _o ≤ max. rated power, I _o ≤ I _o max.	All	-5		+5	%
Over Voltage Protection	Latch off (AC recycle to reset)	LFM300S120			16	V _{dc}
		LFM300S150			20	
		LFM300S240			32	
		LFM300S280			35	
		LFM300S300			36	
		LFM300S480			59	
LFM300S540			63			
Over Current Protection	Auto recovery (output is rated load)	All	110	120	140	%



LFM300S Series

PARAMETER	NOTES and CONDITIONS	Device	Min.	Typ.	Max.	Units
Short Circuit Protection	Auto recovery	All				
Over Temperature Protection	Auto recovery	All				
Output Ripple and Noise	1. Add a 0.1uF ceramic capacitor and a 10uF aluminum electrolytic capacitor to output 2. Oscilloscope is 20MHz band width 3. Ambient Temperature=25°C	LFM300S120			150	mV
		LFM300S150			150	
		LFM300S240			240	
		LFM300S280			280	
		LFM300S300			300	
		LFM300S480			480	
Load Capacitance	1. $V_{in}=115V_{ac}$ and $230V_{ac}$ 2. Output is max. load 3. Ambient temperature=25°C	LFM300S120			15400	uF
		LFM300S150			12200	
		LFM300S240			7800	
		LFM300S280			6600	
		LFM300S300			6200	
		LFM300S480			3870	
Efficiency	1. Input Voltage is 230Vac 2. Output is rated load 3. Ambient temperature=25°C	LFM300S120		93		%
		LFM300S150		93		
		LFM300S240		94		
		LFM300S280		94		
		LFM300S300		94		
		LFM300S480		94		
LFM300S540		93				

ISOLATION CHARACTERISTICS

PARAMETER	NOTES and CONDITIONS	Device	Min.	Typ.	Max.	Units
Input to Output	1 Minute (without dielectric breakdown)	All			4250	V_{ac}
Input to Earth (Ground)	1 Minute (without dielectric breakdown)	All			2000	V_{ac}
Output to Earth (Ground)	1 Minute (without dielectric breakdown)	All			2000	V_{ac}
Isolation Resistance	Input to output	All	100			MΩ

FEATURE CHARACTERISTICS

PARAMETER	NOTES and CONDITIONS	Device	Min.	Typ.	Max.	Units
Switching Frequency	P_{out} =max. rated power	All		100		kHz

GENERAL SPECIFICATIONS

PARAMETER	NOTES and CONDITIONS	Device	Min.	Typ.	Max.	Units
MTBF	$I_o=100\%$; $T_a=25^\circ C$ per MIL-HDBK-217F	All	500			k hours
Life Time	@75% Load, 40°C	All	77			k hours
Humidity	Non-condensing	All			93	% RH
Shock	Meet MIL-STD-810F Table 516.5, Table 516.5-I 10ms, each axis 3 times($\pm X$ 、 $\pm Y$ 、 $\pm Z$ axis)	All		75		g
Vibration	Meet MIL-STD-810F Table 514.5C-VIII, 15~2000Hz, X、Y、Z axis, 1 hour (each axis),. Total 3 hrs.	All		4		g



LFM300S Series

PARAMETER	NOTES and CONDITIONS	Device	Min.	Typ.	Max.	Units
Weight		All		280		grams
Dimensions		All	4.09x2.28x1.00 Inches (104x57.9x25.4 mm)			
Safety	Class I, IEC/EN/UL 62368-1					Ed. 3.0
EMC Emission	EN 55032:2015+A11:2020 (Class B), EN 61000-6-4:2019, EN 61204-3:2018, EN 61000-3-2:2019+A1:2021, EN 61000-3-3:2013+A2:2021, 47 CFR FCC Part 15 Subpart B					
Conducted Disturbance	EN 55032, 47 CFR FCC Part 15					Class B
Radiated Disturbance	EN 55032, 47 CFR FCC Part 15					Class B
Harmonic Current Emissions	EN 61000-3-2:2019+A1:2021					Class A, D
Voltage Fluctuations & Flicker	EN 61000-3-3:2013+A2:2021					Criterion A
EMC Immunity	EN 55035:2017+A11:2020, EN 61000-6-2:2019, EN 61204-3:2018					
Electrostatic Discharge (ESD)	IEC 61000-4-2:2008 Air Discharge: ±8kV, Contact Discharge: ±4kV					Criterion A
Radio-Frequency, Continuous Radiated Disturbance	IEC 61000-4-3:2020					Criterion A
Electrical Fast Transient (EFT)	IEC 61000-4-4:2012, ±2kV					Criterion A
Surge	IEC 61000-4-5:2014+A1:2017, L-N: ±2kV, L-E (Ground): ±4kV					Criterion A
Conducted Disturbances, Induced by RF Fields	IEC 61000-4-6:2013+COR1:2015					Criterion A
Power Frequency Magnetic Field	IEC 61000-4-8:2009					Criterion A
Voltage Dips	IEC 61000-4-11:2020, Dip: 30% 10ms, Dip: 60% 100ms, Dip >95% 5000ms					Criterion A
Voltage Interruptions	IEC 61000-4-11:2020, >95% 5000ms					Criterion B
Application Note Link						LFM300S Series App Notes

CHARACTERISTIC CURVE

Power Derating Curve

Output Power vs Ambient Temperature

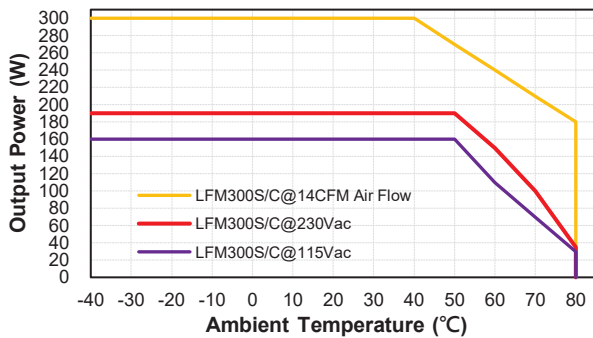

Output Power & Input Voltage

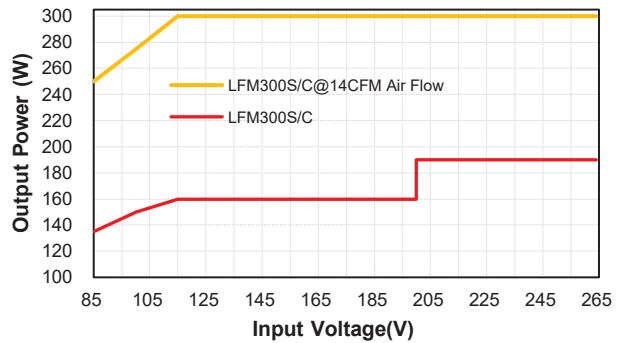



LFM300S Series

Conduction Convection with External Baseplate (22.8cmx22.8cmx0.2cm)

Output Power vs Ambient Temperature

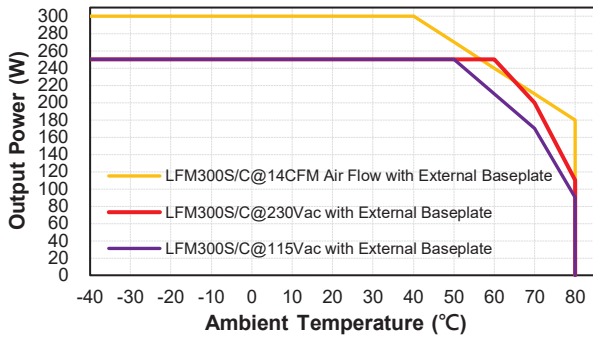

Output Power vs Case Temperature (Tc)

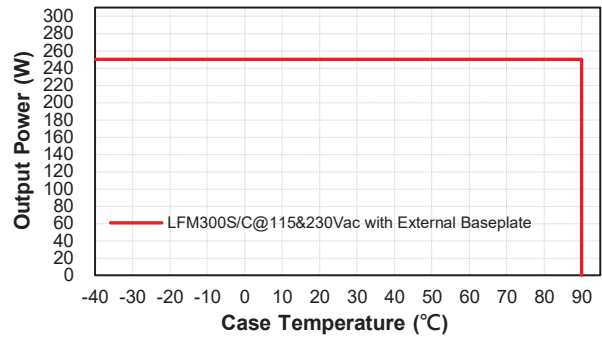

Output Power & Input Voltage

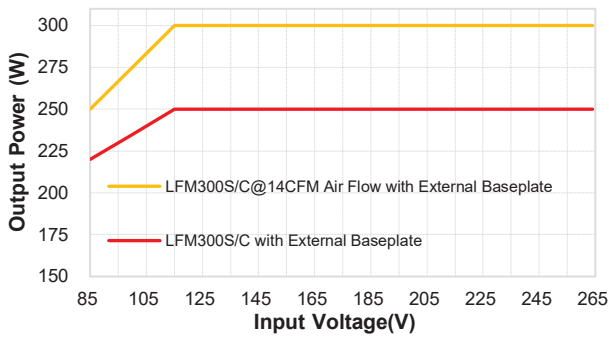

Performance Data

LFM300S120 (Eff Vs Io)

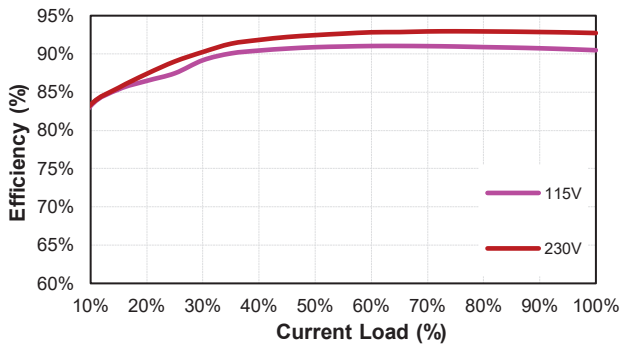

LFM300S150 (Eff Vs Io)

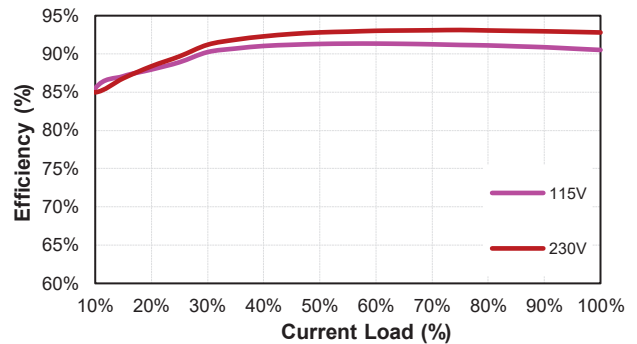

LFM300S240 (Eff Vs Io)

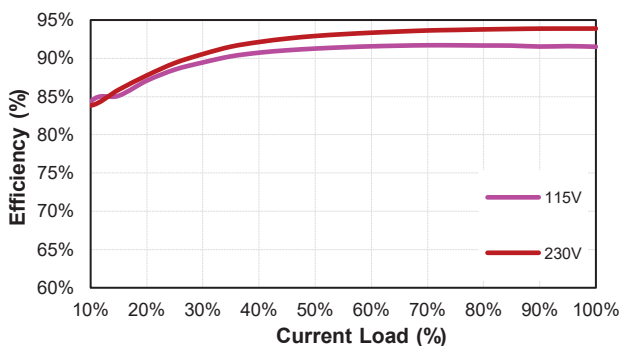

LFM300S280 (Eff Vs Io)

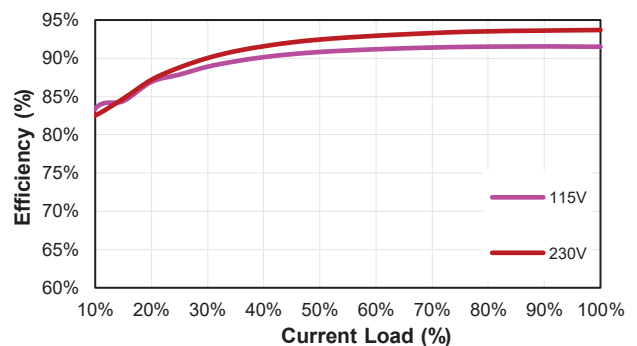



LFM300S Series

LFM300S300 (Eff Vs Io)

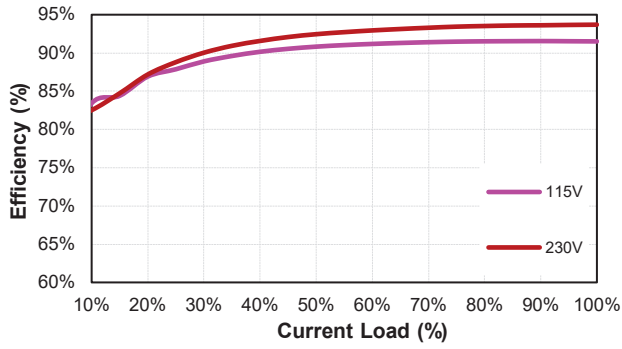

LFM300S480 (Eff Vs Io)

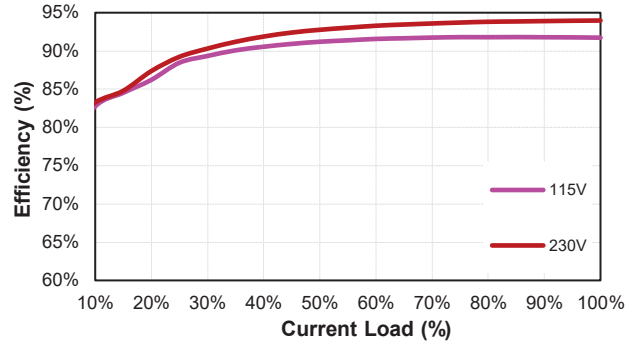

LFM300S540 (Eff Vs Io)

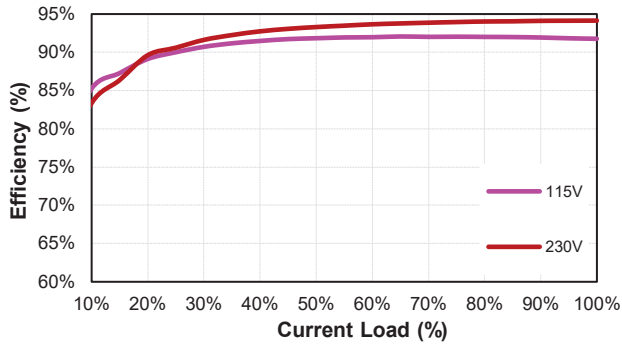



LFM300S Series

MECHANICAL SPECIFICATION

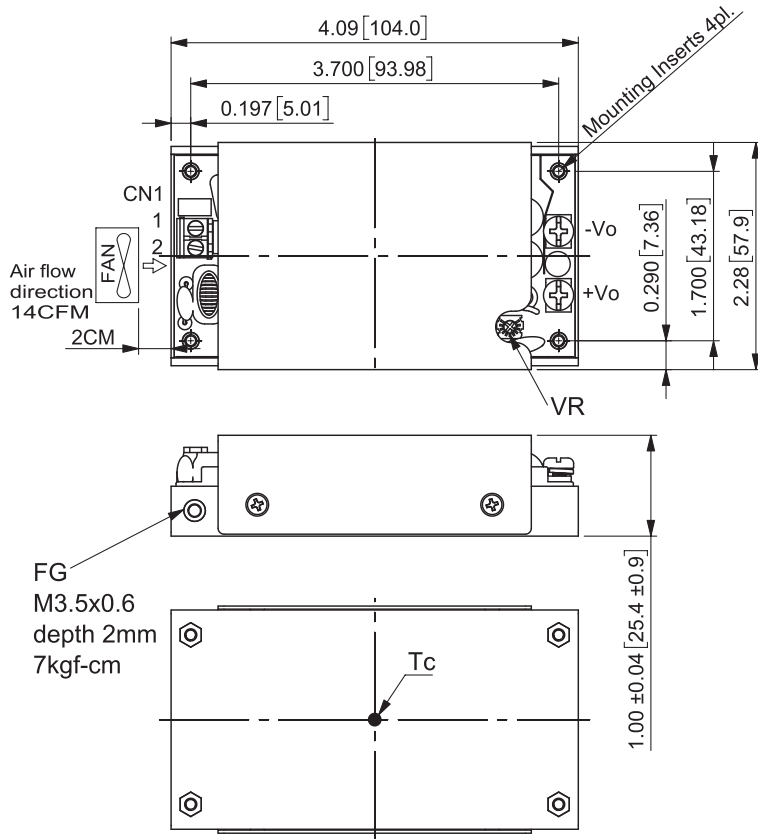

LFM300SXXXC LFM300SXXXC-C0

All Dimensions in Inches[mm]
Tolerance Inches: x.xx=±0.03, x.xxx=±0.020
Millimeters: x.x=±0.7, x.xx=±0.50

AC Input Connector(CN1):ECE ETB22

Pin	Function	Mating Wire Range
1	ACL	14~18 AWG
2	ACN	

DC Output Connector:KANG YANG PCB-58M4

Function	The screw locked torque
+Vo	M4 7kgf-cm
-Vo	

Mounting Inserts

Series	Option
Blank	∅ 3.2 Through depth 10.5mm
-C0	M3x0.5 Threaded depth 10.5mm

CINCON Electronics Co. Ltd.
Add: 14F, No. 306, Sec.4, Hsin Yi Rd., Taipei, Taiwan
Tel: 886-2-27086210
Fax: 886-2-27029852
E-mail: sales@cincon.com.tw
Web: www.cincon.com



LFM420S SERIES 420 WATT AC-DC POWER SUPPLY WITH PFC

Features

- Universal Input Range 85~264Vac
- High Efficiency up to 94.5%
- Class I
- 25.4mm Low Profile Package
- No Load Input Power Consumption <0.5W
- No Load Input Power Consumption <0.6W for 54V
- Approval IEC/EN/UL 62368-1 Ed 3.0
- Approval EN55032 and CISPR/FCC Class B
- Meets IEC/EN 60335-1
- Operating Altitude 5000m
- Continuous Short Circuit Protection
- Over Voltage Protection
- Over Temperature Protection
- High Power Density 25.0 W/Inches³
- Active PFC Function
- Over Voltage Category OVC II & OVC III
- Constant Current



MODEL NUMBER	OUTPUT VOLTAGE	OUTPUT CURRENT			RIPPLE & NOISE NOTE1	VOLTAGE ACCURACY NOTE2	VOLTAGE ADJ. RANGE	LINE REGULATION NOTE3	LOAD REGULATION NOTE4	%EFF. (Typ.) NOTE5
		With Fan NOTE6	Without Conduction Cooling	With Conduction Cooling NOTE7						
LFM420S120C	12 V	35.00 A	23.33 A	29.17 A	120 mV	±1%	11.4-12.6 V	±0.5%	±1%	92.5%
LFM420S150C	15 V	28.00 A	18.67 A	23.33 A	150 mV	±1%	14.25-15.75 V	±0.5%	±1%	93.0%
LFM420S240C	24 V	17.50 A	11.67 A	14.58 A	240 mV	±1%	22.8-25.2 V	±0.5%	±1%	94.0%
LFM420S280C	28 V	15.00 A	10.00 A	12.50 A	280 mV	±1%	28-29.4 V	±0.5%	±1%	94.0%
LFM420S300C	30 V	14.00 A	9.33 A	11.67 A	300 mV	±1%	28.5-31.5 V	±0.5%	±1%	94.0%
LFM420S360C	36 V	11.67 A	7.78 A	9.72 A	360 mV	±1%	34.2-37.8 V	±0.5%	±1%	94.0%
LFM420S480C	48 V	8.75 A	5.83 A	7.29 A	480 mV	±1%	45.6-50.4 V	±0.5%	±1%	94.0%
LFM420S540C	54 V	7.78 A	5.19 A	6.48 A	540 mV	±1%	51.3-55.0 V	±0.5%	±1%	94.5%

Note:

1. Add a 0.1uF ceramic capacitor and a 10uF E.L. capacitor to output for ripple & noise measuring @20MHz BW.
2. Voltage accuracy is set at full load and 25°C Ta.
3. Line regulation is measured from high line to low line with rated load.
4. Load regulation is measured from full load to 10% rated load.
5. Typical efficiency at 230 Vac and full load at 25°C.
6. Forced air convection with 21.9CFM above 100V_{ac}.
7. Conduction convection with external baseplate, 24.8*48.0cm with min. 0.12cm thick.



LFM420S Series

PART NUMBER

Series	Number of Outputs	Nominal Output Voltage	Type	Mounting Inserts
LFM420	O	XXX	X	-YZ
LFM420	S : Single	120 : 12V 150 : 15V 240 : 24V 280 : 28V 300 : 30V 360 : 36V 480 : 48V 540 : 54V	C : With Cover	Blank: Through Hole C0: Threaded Hole

Part Number Example:

LFM420S120C: With Cover, 420W, 12Vdc Output



LFM420S Series

TECHNICAL SPECIFICATIONS

(All specifications are typical at nominal input, full load at 25°C unless otherwise noted.)

ABSOLUTE MAXIMUM RATINGS

PARAMETER	NOTES and CONDITIONS	Device	Min.	Typ.	Max.	Units
Input Voltage	Safety approvals only to the AC input No Safety approvals	All	85		264	V _{ac}
				120		370
Operating Temperature	See Derating Curve	All	-40		80	°C
Operating Case Temperature	At the center of base plate (T _c = Case temperature)	All	-40		85	°C
Storage Temperature		All	-40		85	°C
Operating Altitude	IEC/EN/UL 62368 OVC II IEC/EN/UL 62368 OVC III	All			5000	m
					2000	m

INPUT CHARACTERISTICS

PARAMETER	NOTES and CONDITIONS	Device	Min.	Typ.	Max.	Units
Operating Voltage Range		All	100		240	V _{ac}
Input Frequency Range		All	47		63	Hz
Maximum Input Current	100% Load, V _{in} =100V _{ac}	All			6	A
Leakage Current		All			0.3	mA
Inrush Current	V _{in} =240V _{ac} , Cold start at 25°C	All		30		A
Under Voltage Protection		All	65		75	V _{ac}
Power Factor	230V _{ac} @ Full load	All		0.95		

OUTPUT CHARACTERISTICS

PARAMETER	NOTES and CONDITIONS	Device	Min.	Typ.	Max.	Units
Output Voltage Set Point	V _{in} =Nominal V _{in} , I _o =I _o max., T _c =25°C	LFM420S120	11.88	12	12.12	V _{dc}
		LFM420S150	14.85	15	15.15	
		LFM420S240	23.76	24	24.24	
		LFM420S280	27.72	28	28.28	
		LFM420S300	29.70	30	30.30	
		LFM420S360	35.64	36	36.36	
		LFM420S480	47.52	48	48.48	
		LFM420S540	53.46	54	54.54	
Operating Output Current Range	See Derating Curve	LFM420S120			35.00A	A
		LFM420S150			28.00A	
		LFM420S240			17.50A	
		LFM420S280			15.00A	
		LFM420S300			14.00A	
		LFM420S360			11.67A	
		LFM420S480			8.75A	
		LFM420S540			7.78A	
Holdup Time	V _{in} =115V _{ac} load:350W Ambient temperature=25°C	All		12		ms
	V _{in} =115V _{ac} Load:420W Ambient temperature=25°C			8		
Output Voltage Regulation						
Load Regulation	10% Load to full load	All			±1.0	%
Line Regulation	V _{in} =High line to low line	All			±0.5	%
Output Voltage Adjustment	P _o ≤ max. rated power, I _o ≤ I _o max.	LFM420S280	0		+5	%
	P _o ≤ max. rated power, I _o ≤ I _o max.	LFM420S540	-5		+2	%
	P _o ≤ max. rated power, I _o ≤ I _o max.	Others	-5		+5	%



LFM420S Series

PARAMETER	NOTES and CONDITIONS	Device	Min.	Typ.	Max.	Units
Over Voltage Protection	Latch off (reset after about one minute after the input is turned off)	LFM420S120		16		V _{dc}
		LFM420S150		20		
		LFM420S240		30		
		LFM420S280		35		
		LFM420S300		35		
		LFM420S360		50		
		LFM420S480		63		
		LFM420S540		63		
Over Current Protection	Constant current, auto recovery (see application note)	All	110		170	%
Short Circuit Protection	Auto recovery	All				
Over Temperature Protection	Auto recovery If conduction convection with external baseplate is used or the recommended temperature curve is exceeded, the T _c temperature must be maintained <85°C	All				
Output Ripple and Noise	1. Add a 0.1uF ceramic capacitor and a 10uF aluminum electrolytic capacitor to output 2. Oscilloscope is 20MHz Band Width 3. Ambient Temperature=25°C	LFM420S120			120	mV
		LFM420S150			150	
		LFM420S240			240	
		LFM420S280			280	
		LFM420S300			300	
		LFM420S360			360	
		LFM420S480			480	
		LFM420S540			540	
Load Capacitance	1. V _{in} =115V _{ac} and 230V _{ac} 2. Output is max. load 3. Ambient temperature=25°C	LFM420S120			29100	uF
		LFM420S150			23300	
		LFM420S240			14500	
		LFM420S280			12500	
		LFM420S300			11600	
		LFM420S360			9700	
		LFM420S480			7200	
		LFM420S540			6400	
Efficiency	1. Input Voltage is 230V _{ac} 2. Output is rated load 3. Ambient temperature=25°C	LFM420S120		92.5%		%
		LFM420S150		93.0%		
		LFM420S240		94.0%		
		LFM420S280		94.0%		
		LFM420S300		94.0%		
		LFM420S360		94.0%		
		LFM420S480		94.0%		
		LFM420S540		94.5%		

ISOLATION CHARACTERISTICS

PARAMETER	NOTES and CONDITIONS	Device	Min.	Typ.	Max.	Units
Input to Output	1 Minute (without dielectric breakdown)	All			4250	V _{ac}
Input to Earth (Ground)	1 Minute (without dielectric breakdown)	All			2000	V _{ac}
Output to Earth (Ground)	1 Minute (without dielectric breakdown)	All			2000	V _{ac}
Isolation Resistance	Input to Output	All	100			MΩ

FEATURE CHARACTERISTICS

PARAMETER	NOTES and CONDITIONS	Device	Min.	Typ.	Max.	Units
Switching Frequency	P _{out} =max. rated power	All		65		kHz



LFM420S Series

GENERAL SPECIFICATIONS

PARAMETER	NOTES and CONDITIONS	Device	Min.	Typ.	Max.	Units
MTBF	$I_o=100\%$; $T_a=25^\circ\text{C}$ per MIL-HDBK-217F	All		400		K hours
Humidity	Non-condensing	All			93	% RH
Shock	Meet MIL-STD-810F Table 516.5, Table 516.5-1 10ms, each axis 3 times ($\pm X$ 、 $\pm Y$ 、 $\pm Z$ axis)	All		75		g
Vibration	Meet MIL-STD-810F Table 514.5C-VIII, 15~2000Hz, X、Y、Z axis, 1 hour (each axis),. Total 3 hrs.	All		4		g
Weight		All		470		g
Dimensions		All	5.09x3.29x1.00 Inches (129.4x83.5x25.4mm)			
Safety	Class I, IEC/EN/UL 62368-1					Ed. 3.0
EMC Emission	EN 55032:2015+A11:2020 (Class B), EN 61000-6-3:2021, EN 61000-6-4:2019, EN 61204-3:2018, EN 61000-3-2:2019+A1:2021, EN 61000-3-3:2013+A2:2021, 47 CFR FCC Part 15 Subpart B					Class B
Conducted Disturbance	EN 55032, 47 CFR FCC Part 15 Subpart B (Class B)					Class B
Radiated Disturbance	EN 55032, 47 CFR FCC Part 15 Subpart B (Class B)					Class B
Harmonic Current Emissions	EN 61000-3-2:2019+A1:2021					Class A, C, D
Voltage Fluctuations & Flicker	EN 61000-3-3:2013+A2:2021					
EMC Immunity	EN 55035:2017+A11:2020, EN 61000-6-1:2019+CRGD:2019, EN 61000-6-2:2019, EN 61204-3:2018					
Electrostatic Discharge (ESD)	IEC 61000-4-2:2008, Air Discharge: $\pm 8\text{kV}$, Contact Discharge: $\pm 4\text{kV}$					Criterion A
Radio-Frequency, Continuous Radiated Disturbance	IEC 61000-4-3:2020					Criterion A
Electrical Fast Transient (EFT)	IEC 61000-4-4:2012, $\pm 2\text{kV}$					Criterion A
Surge	IEC 61000-4-5:2014+A1:2017, Line-Line: $\pm 2\text{kV}$, Line-Earth (Ground): $\pm 4\text{kV}$					Criterion A
Conducted Disturbances, Induced by RF Fields	IEC 61000-4-6:2013+COR1:2015					Criterion A
Power Frequency Magnetic Field	IEC 61000-4-8:2009					Criterion A
Voltage Dips	IEC 61000-4-11:2020, Dip: 30% Reduction, Dip >95% Reduction					Criterion A
Voltage Interruptions	IEC 61000-4-11:2020, >95% Reduction					Criterion B
Application Note Link						LFM420S Series App Notes

CHARACTERISTIC CURVE

Power Derating Curve

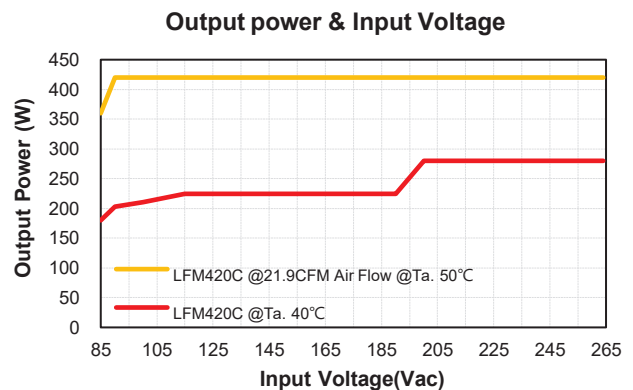
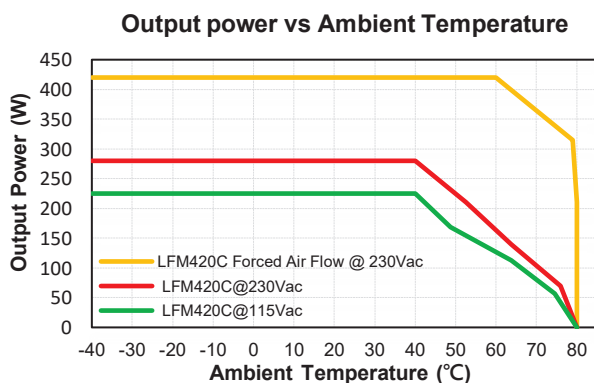



LFM420S Series

Conduction Convection with External Baseplate (24.8cmx48cmx0.12cm)

Output power vs Ambient Temperature

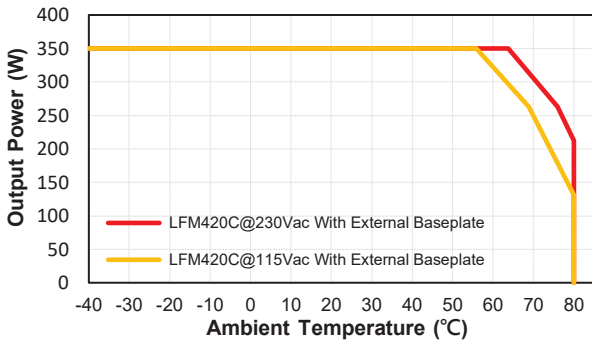

Natural Convection With External Baseplate Output power & Input Voltage

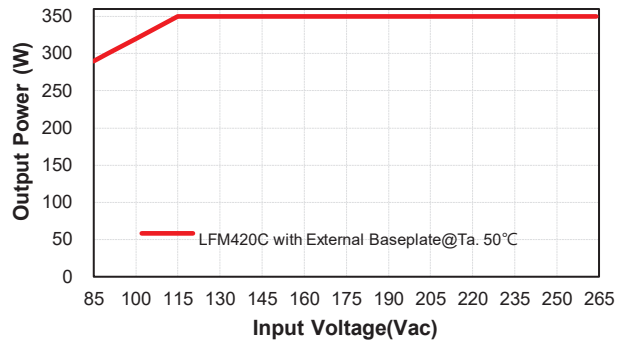

Output power vs Case Temperature

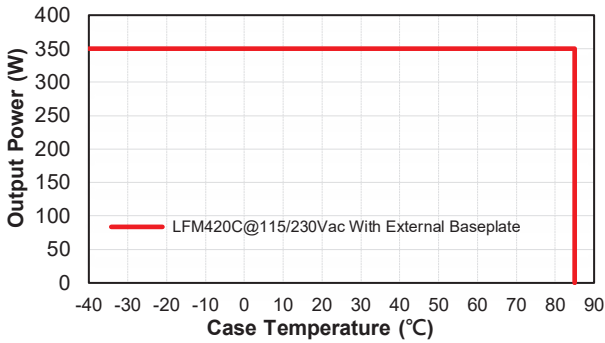

Performance Data

LFM420S120 (Eff Vs Io)

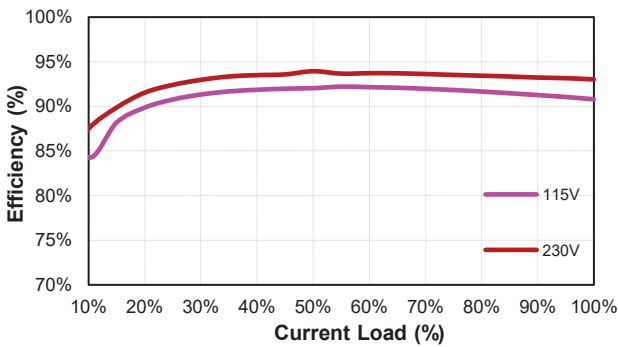

LFM420S150 (Eff Vs Io)

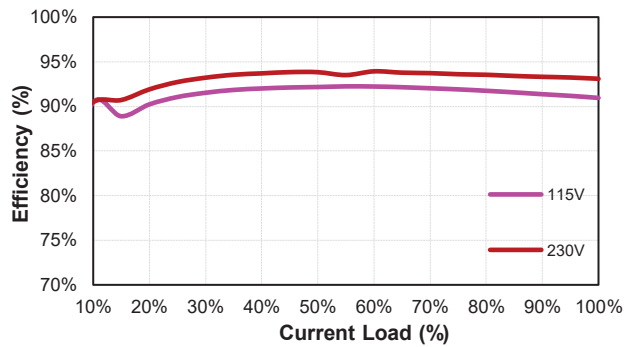

LFM420S240 (Eff Vs Io)

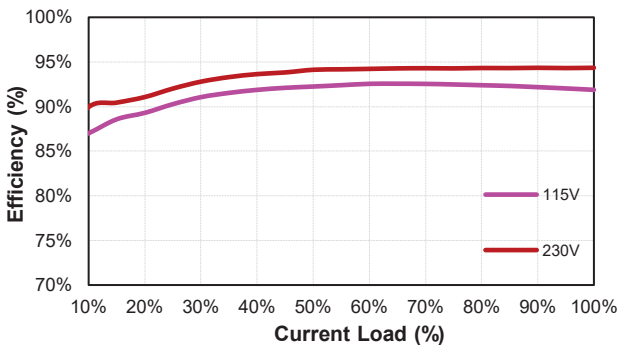

LFM420S280 (Eff Vs Io)

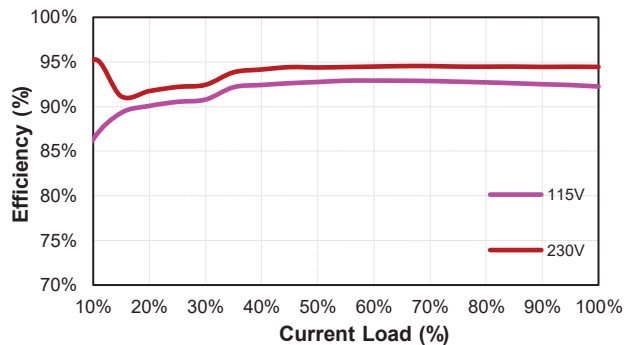



LFM420S Series

LFM420S300 (Eff Vs Io)

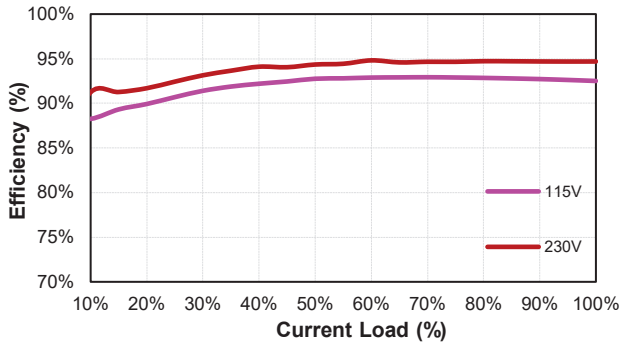

LFM420S360 (Eff Vs Io)

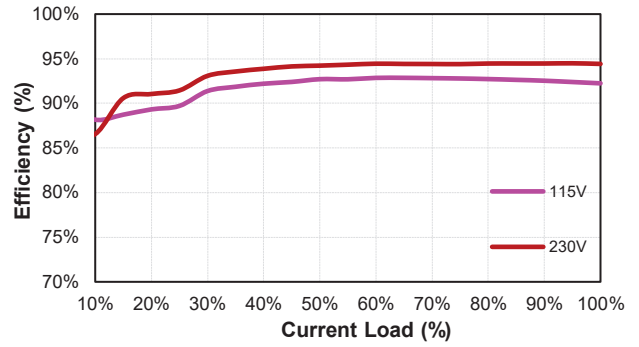

LFM420S480 (Eff Vs Io)

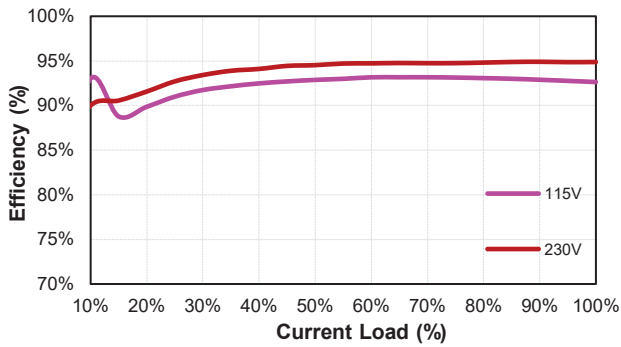

LFM420S540 (Eff Vs Io)

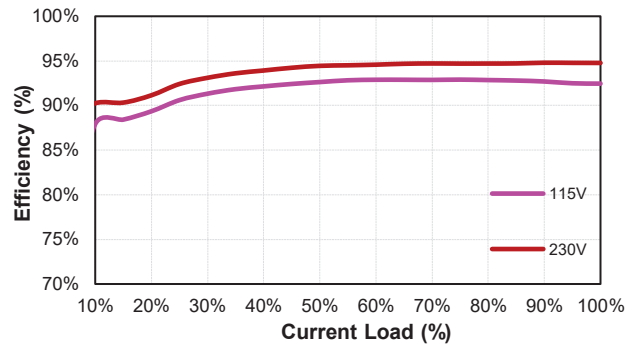



LFM420S Series

MECHANICAL SPECIFICATION

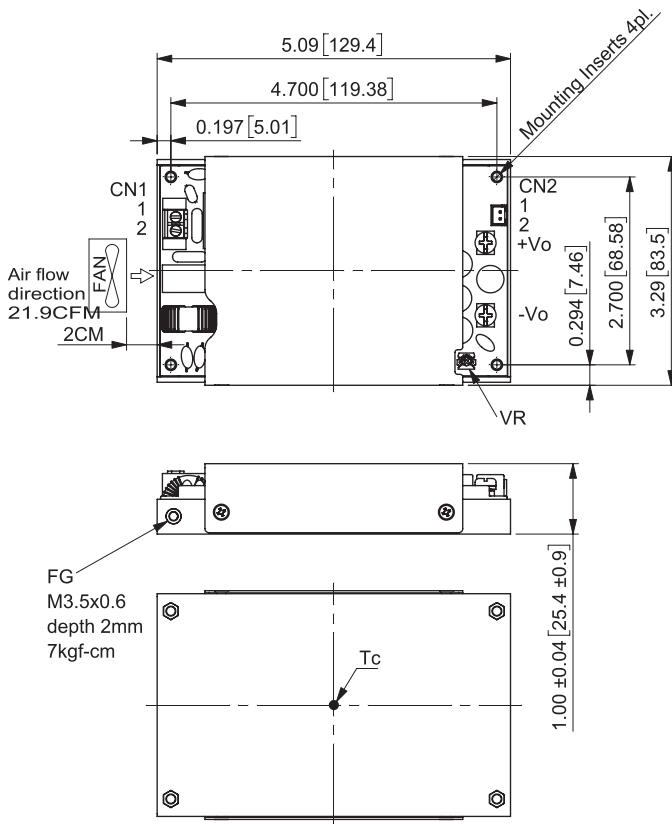

LFM420SXXXC LFM420SXXXC-C0

All Dimensions in Inches[mm]
Tolerance Inches: x.xx=±0.03, x.xxx=±0.020
Millimeters: x.x=±0.7, x.xx=±0.50

AC Input Connector(CN1):ECE ETB22

Pin	Function	Mating Wire Range
1	ACL	14~18 AWG
2	ACN	

DC Output Connector(CN2):TKP 8822-02-NHB or equivalent

Pin	Function	Mating Housing	Terminal
1	Rs+	JST XHP-2 or equivalent	JST
2	Rs-		SXH-001T-P0.6N or equivalent

DC Output Connector:KANG YANG PCB-58M4

Function	The screw locked torque
+Vo	M4 7kgf-cm
-Vo	

Mounting Inserts

Series	Option
Blank	∅3.2 Through depth 10.5mm
-C0	M3x0.5 Threaded depth 10.5mm